

4/2- and 4/3-way proportional directional valves, direct operated, without electrical position feedback, without/with integrated electronics (OBE)

Types 4WRA and 4WRAE

Nominal sizes 6 and 10
 Component series 2X
 Maximum operating pressure 315 bar
 Maximum flow: 42 l/min (NS6)
 75 l/min (NS10)

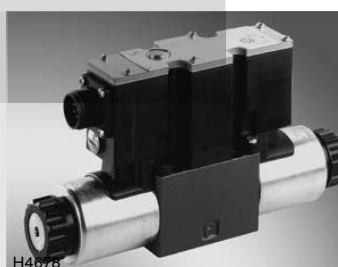

Type 4WRAE 6 ...-2X/G24K31/V
 with integrated electronics (OBE)

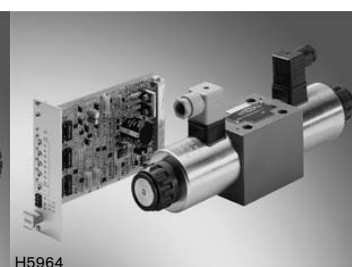

Typ 4WRA 10 ...-2X/G24...K4/V
 with plug-in connectors and
 associated control electronics
 (separate order)

Overview of contents

Contents	Page
Features	1
Ordering details	2
Symbols	3
Function, section	4
Technical data	5, 6
Control electronics	6
Electrical connections, plug-in connectors	7
Integrated electronics (OBE) for type 4WRAE	8
Characteristic curves	9...11
Unit dimensions	12 ...15

Features

- Direct operated proportional directional valve without electrical position feedback and integrated electronics (OBE) for type 4WRAE
- Control the direction and magnitude of a flow
- Actuation by means of proportional solenoids with central thread and removable coil
- For subplate mounting:
 - Connection position to ISO 4401
 - Subplates to catalogue sheets RE 45052 (NS6) or RE 45054 (NS10) separate order, see page 12 to 15
- Spring centred control spool
- Control electronics
 - 4WRAE:
 - integrated electronics (OBE) with voltage input or current input (A1 resp. F1)
 - 4WRA:
 - digital or analogue amplifier in Eurocard format (separate order)
 - analogue module amplifier

For information regarding the available spare parts see:
www.boschrexroth.com/spc

Ordering details

4WRA				-2X/	G24		/	V	*
------	--	--	--	------	-----	--	---	---	---

Without integrated electronics (OBE) = No code
 With integrated electronics (OBE) = E
 Nominal size 6 = 6
 Nominal size 10 = 10

Spool symbols

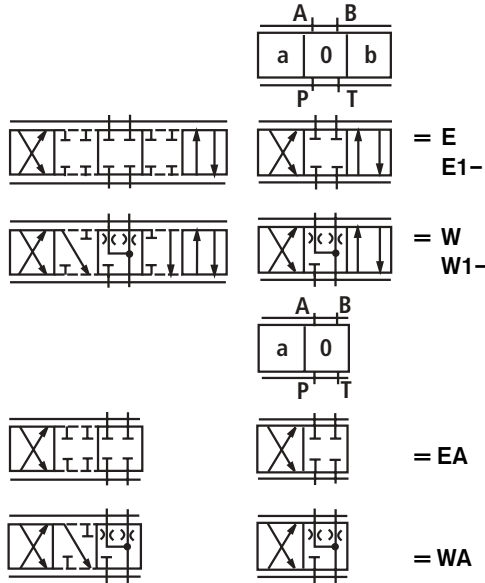

With spool symbols E1- and W1-:
 P → A: $q_{V \max}$ B → T: $q_V/2$
 P → B: $q_V/2$ A → T: $q_{V \max}$

Note:
 With spools W and WA, in the neutral position, there is a connection from A to T and B to T with approx. 3 % of the relevant nominal cross-section.

Further details in clear text

Seal material
 FKM seals, suitable for mineral oil (HL, HLP) to DIN 51524

V =

Electronic interfaces A1 or F1 for 4WRAE

A1 = Command value input ± 10 V

F1 = Command value input 4 to 20 mA

No code = For 4WRA

Electrical connections

for 4WRA:

K4 ²⁾ = Without plug-in connector, with component plug to DIN EN 175301-803
 plug-in connector – separate order, see page 7

for 4WRAE:

K31 ²⁾ = Without plug-in connector, with component plug to DIN EN 175201-804
 plug-in connector – separate order, see page 7

Special protection

No code = Without special protection

J ¹⁾ = Sea water resistant (only for NS6)

For details regarding the sea water resistant versions see RE 29055-M

G24 = Supply voltage 24 VDC

2X = Component series 20 to 29
 (20 to 29: unchanged installation and connection dimensions)

Nominal flow at a valve pressure differential $\Delta p = 10$ bar

07 =	NS6
15 =	7 l/min
30 =	15 l/min
	26 l/min
	NS10
30 =	30 l/min
60 =	60 l/min

¹⁾ Other types of electrical protection on request

²⁾ Only for NS6: for version "J" = sea water resistant only state "K31"!

Symbols

Without integrated electronics

Type 4WRA...

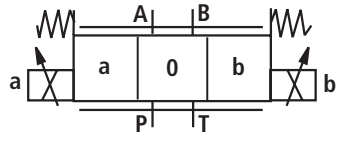

With integrated electronics (OBE)

Type 4WRAE...

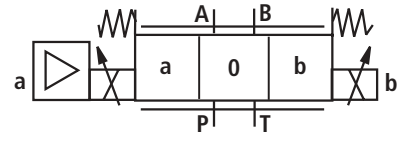

Types 4WRA...**EA**...; 4WRA...**WA**...

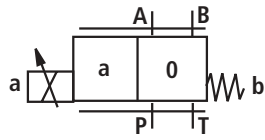

Types 4WRAE...**EA**...; 4WRAE...**WA**...

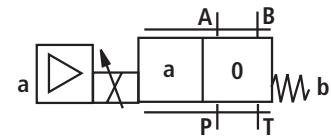

Function, section

The 4/2- and 4/3-way proportional directional valves are designed as direct operated components for subplate mounting. They are actuated by means of proportional solenoids with central thread and removable coil. The solenoids are controlled either by external control electronics (type 4WRA) or by integrated control electronics (type 4WRAE).

Design:

The valves basically consist of:

- Housing (1) with mounting surface
- Control spool (2) with compression springs (3 and 4)
- Solenoids (5 and 6) with central thread
- Optional integrated electronics (7)

Function:

- With the solenoids (5 and 6) de-energised, the control spool (2) is held in the central position by compression springs (3 and 4)
- Direct actuation of the control spool (2) by energising a proportional solenoid
E.g. energisation of solenoid "b" (6)
→ The control spool (2) is moved to the left in proportion to the electrical input signal
→ connection from P to A and B to T via orifice-like cross-sections with progressive flow characteristics
- De-energisation of the solenoid (6)
→ The control spool (2) is returned to the central position by compression spring (3)

Type 4WRA 6...-2X/...

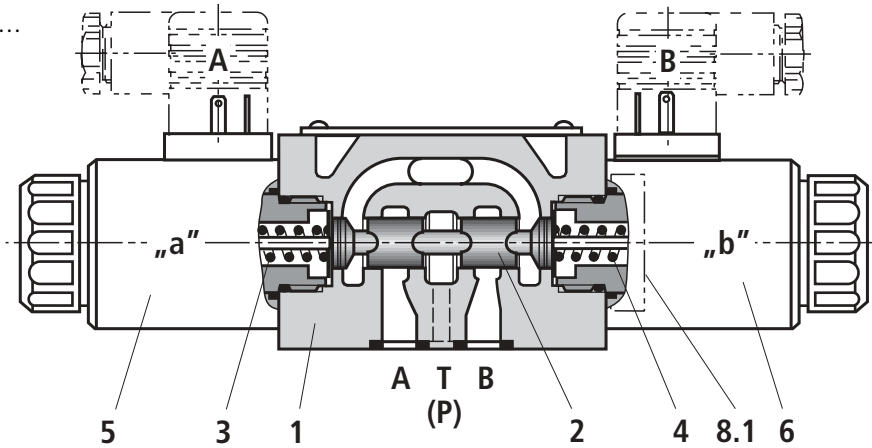

Type 4WRAE 10...-2X/...

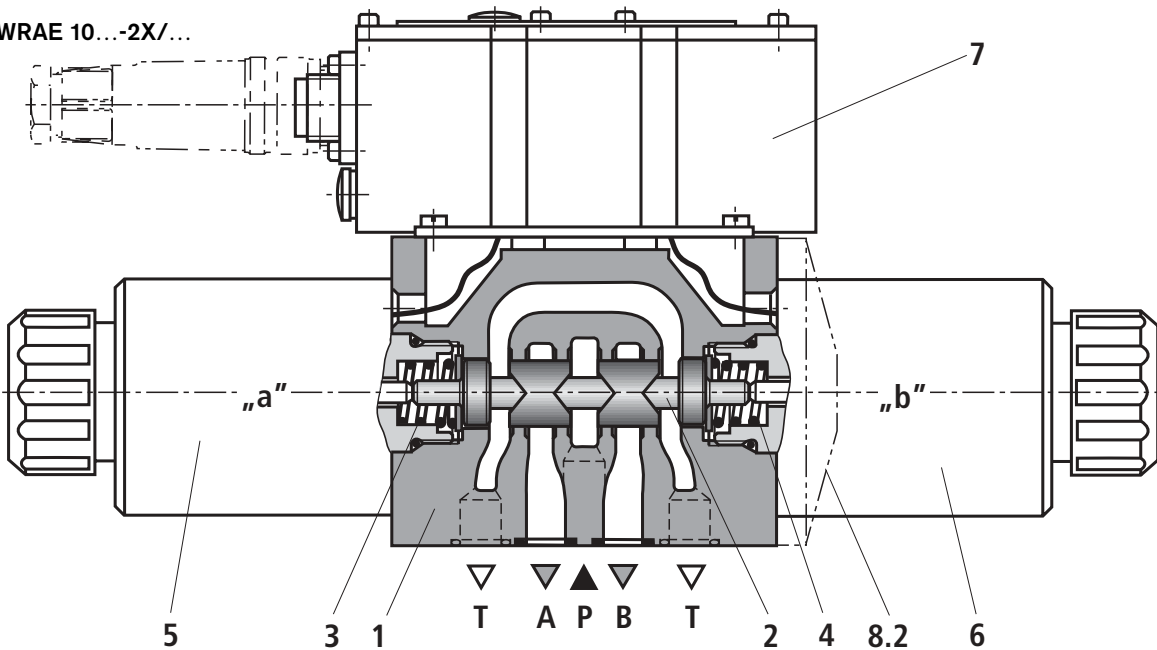

Valve with 2 spool positions:

(Type 4WRA...A...)

In principle, the function of this valve version corresponds to that of the valve with 3 spool positions. However, the valves with 2 spool positions are **only fitted with solenoid "a"**. Instead of the 2nd proportional solenoid a plug (8.1) is fitted for NS 6 or for NS 10 a cover (8.2).

Note for type 4WRA 6...-2X/...:

Draining of the tank line is to be avoided. With the appropriate installation conditions, a back pressure valve is to be installed (back pressure approx. 2 bar).

Technical data (for applications outside these parameters, please consult us!)

General

Nominal size	NS		6	10
Installation			optional, preferably horizontal	
Storage temperature range	°C		-20 to +80	
Ambient temperature range	4WRA °C		-20 to +70	
	4WRAE °C		-20 to +50	
Weight	4WRA	kg	2.0	6.6
	4WRAE	kg	2.2	6.8

Hydraulic (measured with HLP46, $\vartheta_{oil} = 40 \text{ °C} \pm 5 \text{ °C}$)

Max. operating pressure	Ports A, B, P	bar	315	
	Port T	bar	210	
Nominal flow $q_{V\text{ nom}}$ at $\Delta p = 10 \text{ bar}$		l/min	7, 15, 26	30, 60
Max. permissible flow		l/min	42 (80) ¹⁾	75 (140) ¹⁾
Pressure fluid			mineral oil (HL, HLP) to DIN 51524 other pressure fluids on request!	
Pressure fluid temperature range		°C	-20 to +80 (preferably +40 to +50)	
Viscosity range		mm ² /s	20 to 380 (preferably 30 to 46)	
Max. permissible degree of pressure fluid contamination cleanliness class to ISO 4406 (c)			class 20/18/15 ²⁾	
Hysteresis		%	≤ 5	
Reversal error		%	≤ 1	
Response sensitivity		%	≤ 0.5	

¹⁾ Max. permissible flow with a dual flow path

²⁾ The cleanliness class stated for the components must be adhered too in hydraulic systems. Effective filtration prevents faults from occurring and at the same time increases the component service life.
For the selection of filters see catalogue sheets RE 50070, RE 50076, RE 50081, RE 50086 and RE 50088.

Technical data (for applications outside these parameters, please consult us!)

Electical

Nominal size	NS	6	10
Voltage type		DC	
Command value signal	Voltage input „A1“	V	±10
with type WRAE	Current input „F1“	mA	4 to 20
Max. current per solenoid		A	2.5
Solenoid coil resistance	Cold value at 20 °C	Ω	2
	Max. warm value	Ω	3
Duty		%	100
Max. coil temperature ¹⁾		°C	150
Electrical connections see page 7	4WRA	with component plug to DIN EN 175301-803 or ISO 4400	
		plug-in connector to DIN EN 175301-803 or ISO 4400 ²⁾	
	4WRAE	with component plug to DIN EN 175201-804	
		plug-in connector DIN EN 175201-804 ²⁾	
Valve protection to EN 60529		IP65 with mounted and fixed plug-in connector	

Control electronics

For 4WRA	Digital amplifier in Eurocard format ²⁾		VT-VSPD-1-2X (to RE 30523 - middle of 2006)
	Analogue amplifier in Eurocard format ²⁾		VT-VSPA2-1-2X/... to RE 30110
	Analogue module amplifier ²⁾		VT-MSPA2-1-1X to RE 30228
For 4WRAE			integrated into the valves, see page 8
	Analogue command value module		VT- SWMA-1-1X/... to RE 29902
	Analogue command value module		VT-SWMKA-1-1X/... to RE 29903
	Digital command value card		VT-HACD-1-1X/... to RE 30143
	Analogue command value card		VT-SWKA-1-1X/... to RE 30255
Supply voltage	Nominal voltage	VDC	24
4WRAE, 4WRA ³⁾	Lower limiting value	V	21 / 22 (4WRA); 19 (4WRAE)
	Upper limiting value	V	35
Amplifier current	I_{max}	A	1.8
consumption	Max. impulse current	A	3

¹⁾ Due to the occurring surface temperature of the solenoid coils, the European Standards DIN EN 563 and DIN EN 982 must be taken into account!

²⁾ Separate order

³⁾ With Prance Hydraulic AG control electronics

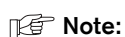

Note:

For details regarding the **environmental simulation test** covering EMC (electromagnetic compatibility), climate and mechanical loading see RE 29055-U (declaration regarding environmental compatibility).

Electrical connection, plug-in connectors

For type WRA

(without integrated electronics – not for version "J" = sea water resistant)

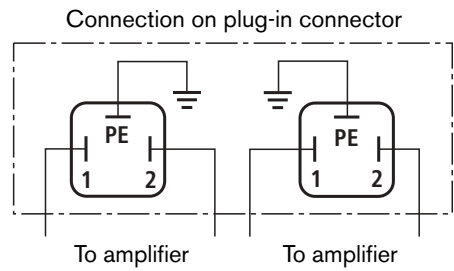
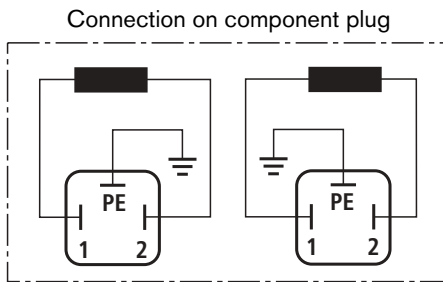

Plug-in connector CECC 75 301-803-A002FA-H3D08-G to DIN EN 175301-803 or ISO 4400

Solenoid **a**, colour grey

Separate order: Material No. **R901017010**

Solenoid **b**, colour black

Separate order: Material No. **R901017011**

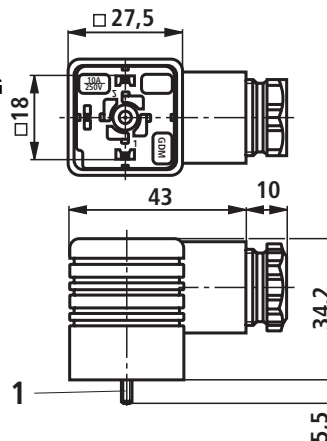

1 Fixing screws M3
Tightening torque $M_A = 0.5 \text{ Nm}$

For type WRAE

(with integrated electronics (OBE) and for version "J" = sea water resistant)

For pin allocation, see block circuit diagram on page 8

Plug-in connector to DIN EN 175201-804

Separate order: Material No. **R900021267**

(plastic version)

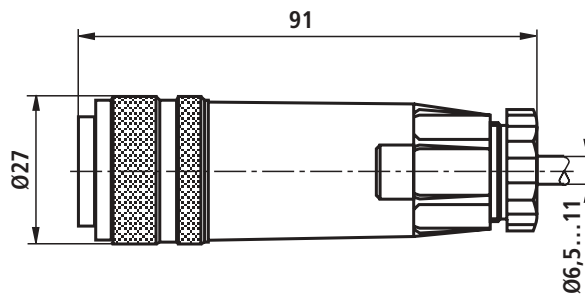

Plug-in connector to DIN EN 175201-804

Separate order: Material No. **R900223890**

(metal version)

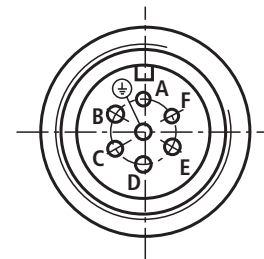
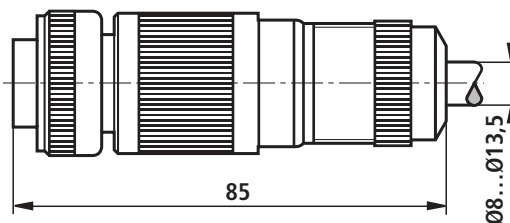

Integrated electronics (OBE) for type WRAE

Pin allocation of the component plug

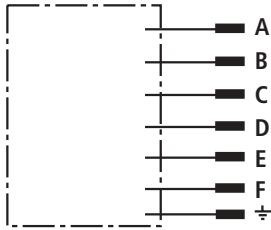

Integrated control electronics (see below)

Pin allocation	Contact	Signal
Supply voltage	A	24 VDC (19 to 35 VDC)
	B	GND
	C	n.c. ¹⁾
Differential amplifier input	D	Com. value (± 10 V / 4 to 20 mA)
	E	reference potential
	F	n.c.

Com. value: Positive command value (0 to 10 V or 12 to 20 mA) at D and reference potential to E causes flow from P to A and B to T.

Negative command value (0 to -10 V or 12 to 4 mA) at D and reference potential to E causes flow from P to B and A to T.

For valves with a solenoid on side „A“ (spool variants **EA** and **WA**) a positive command value at D and reference potential to E (NS 6: 4 to 20 mA and NS 10: 12 to 20 mA) causes flow from P to B and A to T.

Connection cable: Recommendation: – up to 25 m cable length type LiYCY 5 x 0.75 mm²
– up to 50 m cable length type LiYCY 5 x 1.0 mm²

External diameter 6.5 to 11 mm

Connect screen to PE only on the supply side.

¹⁾ Contacts C and F must not be connected!

Block circuit diagram / connection allocation

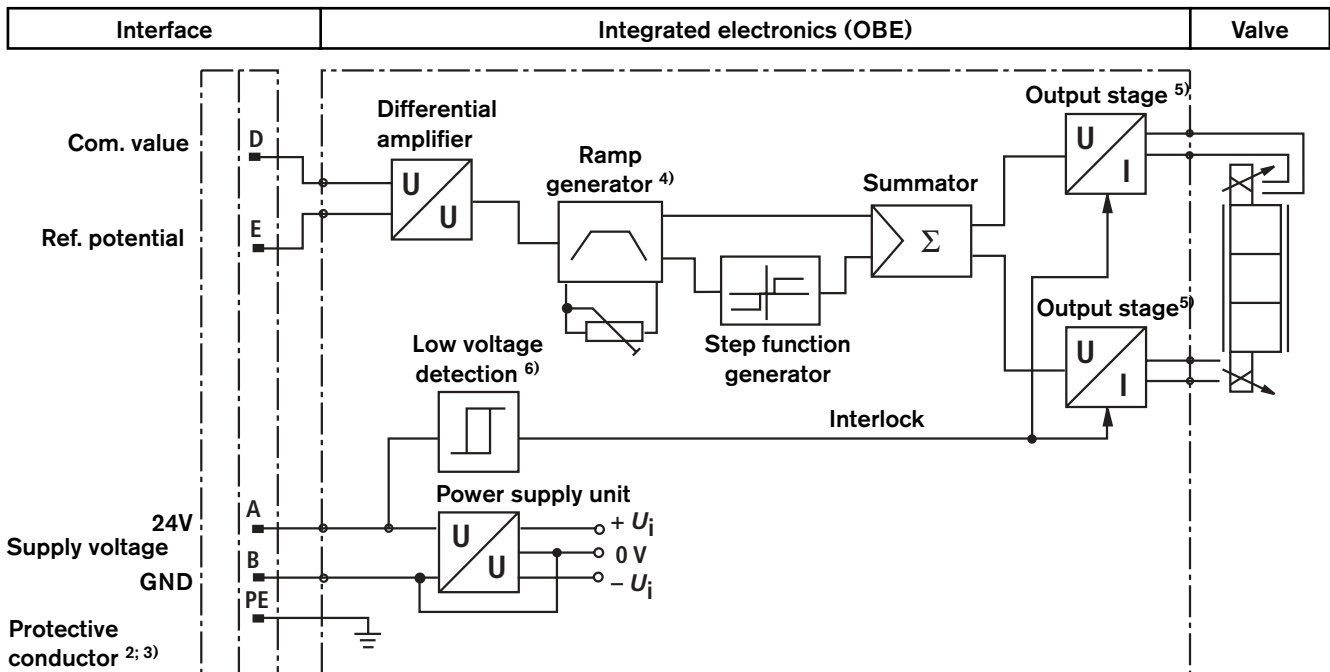

²⁾ PE is connected to the cooling body and the valve housing

³⁾ Protective conductor screwed to the valve housing and cover

⁴⁾ Ramp can be externally adjusted from 0 to 2.5 s; the same applies for T_{up} and T_{down}

⁵⁾ Output stages current regulated

⁶⁾ Low voltage detection is **not** carried out for component type 4WRAE 10-2X.

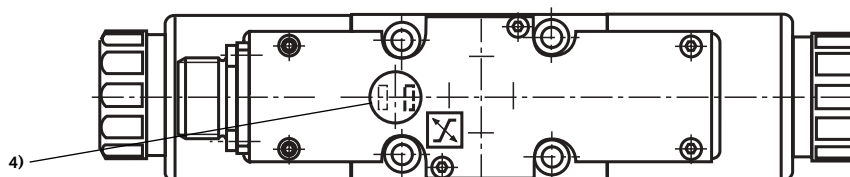

Characteristic curves (measured with HLP46, $\vartheta_{oil} = 40\text{ °C} \pm 5\text{ °C}$)

NS6

7 l/min nominal flow at 10 bar valve pressure differential

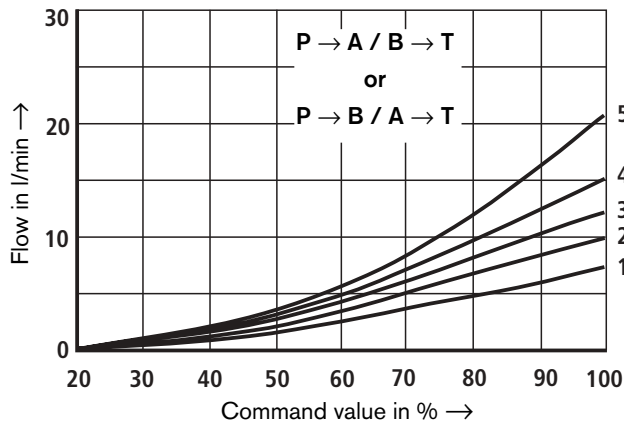

15 l/min nominal flow at 10 bar valve pressure differential

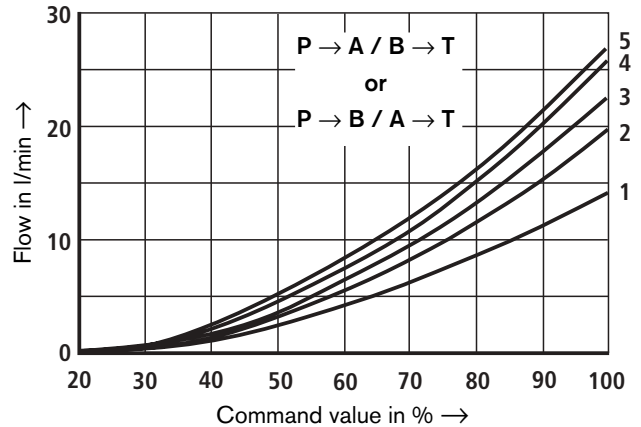

30 l/min nominal flow at 10 bar valve pressure differential

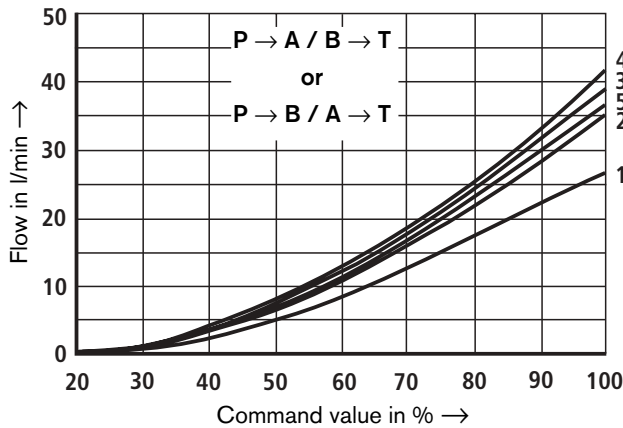

- 1 $\Delta p = 10\text{ bar}$ constant
- 2 $\Delta p = 20\text{ bar}$ constant
- 3 $\Delta p = 30\text{ bar}$ constant
- 4 $\Delta p = 50\text{ bar}$ constant
- 5 $\Delta p = 100\text{ bar}$ constant

$\Delta p =$ Valve pressure differential (inlet pressure p_p minus load pressure p_L and minus return pressure p_T)

Characteristic curves (measured with HLP46, $\vartheta_{oil} = 40\text{ °C} \pm 5\text{ °C}$)

NS10

30 l/min nominal flow at 10 bar valve pressure differential

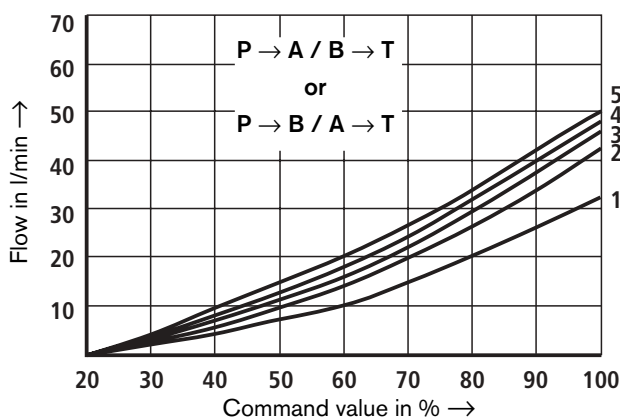

- 1 $\Delta p = 10\text{ bar}$ constant
- 2 $\Delta p = 20\text{ bar}$ constant
- 3 $\Delta p = 30\text{ bar}$ constant
- 4 $\Delta p = 50\text{ bar}$ constant
- 5 $\Delta p = 100\text{ bar}$ constant

60 l/min nominal flow at 10 bar valve pressure differential

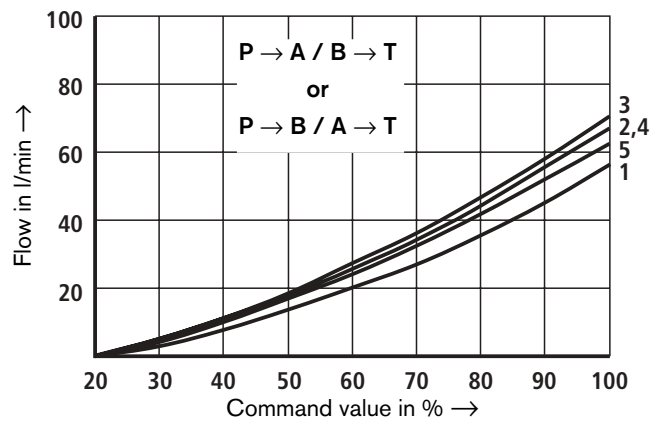

$\Delta p =$ Valve pressure differential (inlet pressure p_p minus load pressure p_L and minus return pressure p_T)

Characteristic curves (measured with HLP46, $\vartheta_{oil} = 40\text{ }^{\circ}\text{C} \pm 5\text{ }^{\circ}\text{C}$)

NS6

Transient functions with stepped form of electrical input signals

Types 4WRA and 4WRAE

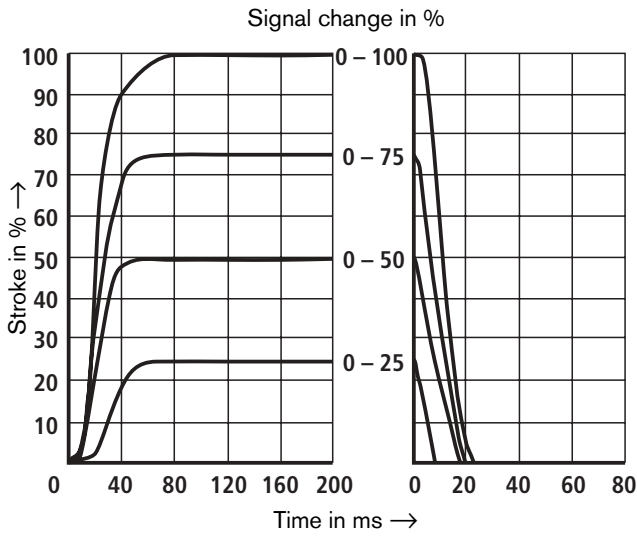

Performance limit, nominal flow 7 l/min

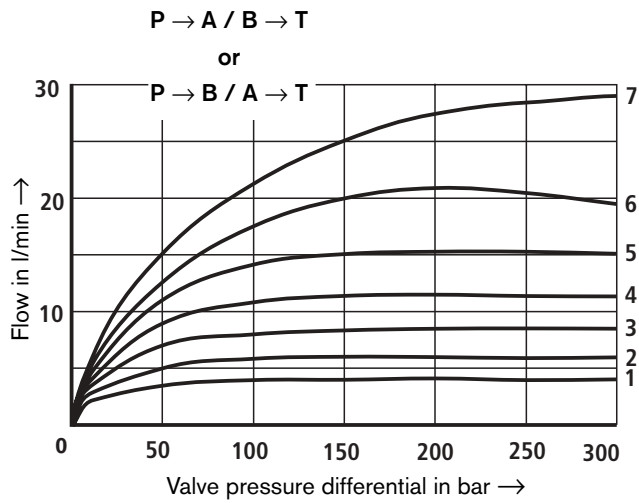

Performance limit, nominal flow 15 l/min

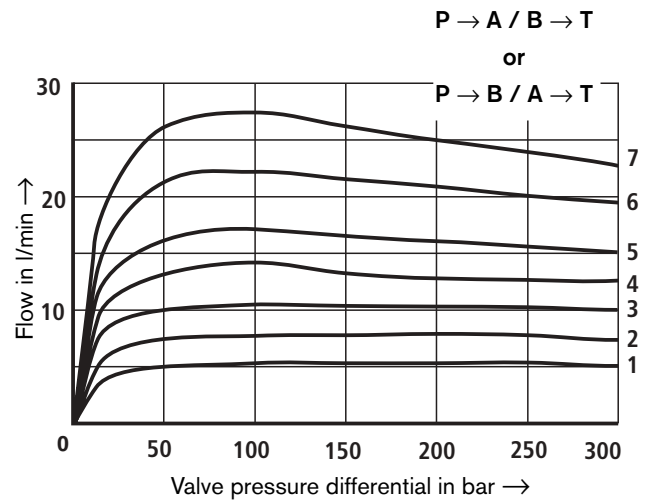

Performance limit, nominal flow 30 l/min

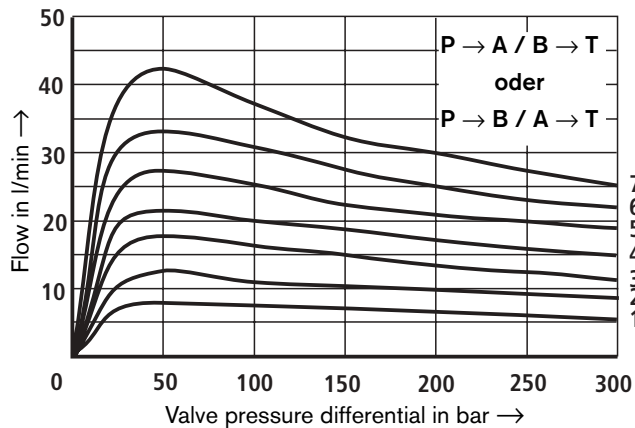

- 1 Com. value = 40 %
- 2 Com. value = 50 %
- 3 Com. value = 60 %
- 4 Com. value = 70 %
- 5 Com. value = 80 %
- 6 Com. value = 90 %
- 7 Com. value = 100 %

If the performance limits are exceeded then flow forces occur which lead to uncontrolled spool movements.

Characteristic curves (measured with HLP46, $\vartheta_{oil} = 40\text{ °C} \pm 5\text{ °C}$)

NS10

Transient functions with stepped form of electrical input signals

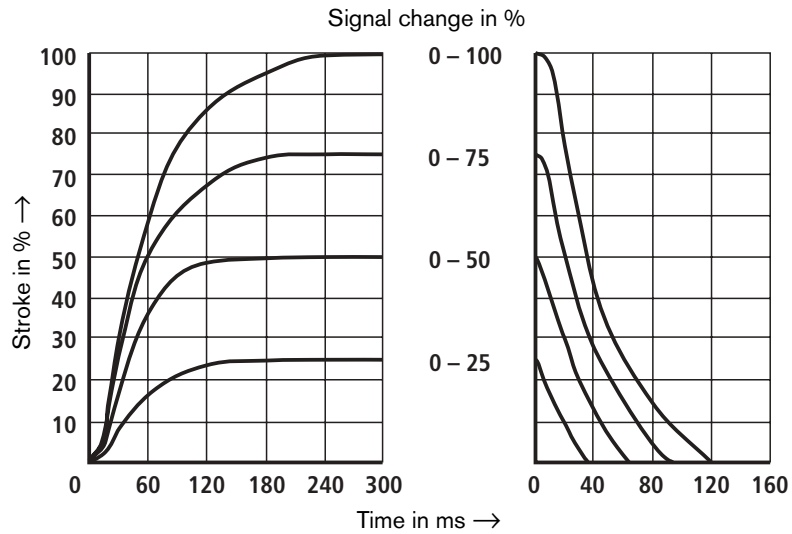

Performance limit, nominal flow 30 l/min

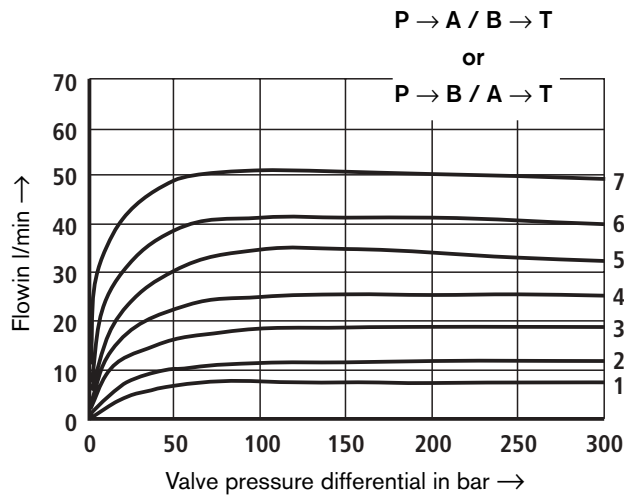

Performance limit, nominal flow 60 l/min

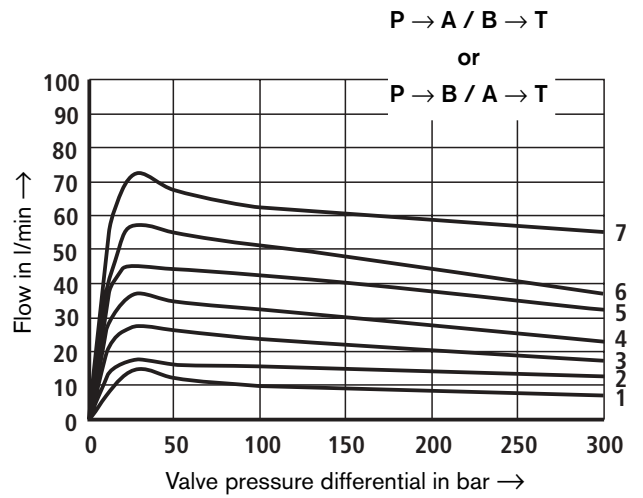

- 1 Com. value = 40 %
- 2 Com. value = 50 %
- 3 Com. value = 60 %
- 4 Com. value = 70 %
- 5 Com. value = 80 %
- 6 Com. value = 90 %
- 7 Com. value = 100 %

If the performance limits are exceeded then flow forces occur which lead to uncontrolled spool movements.

Unit dimensions: Type 4WRA 6 (nominal dimensions in mm)

NS6

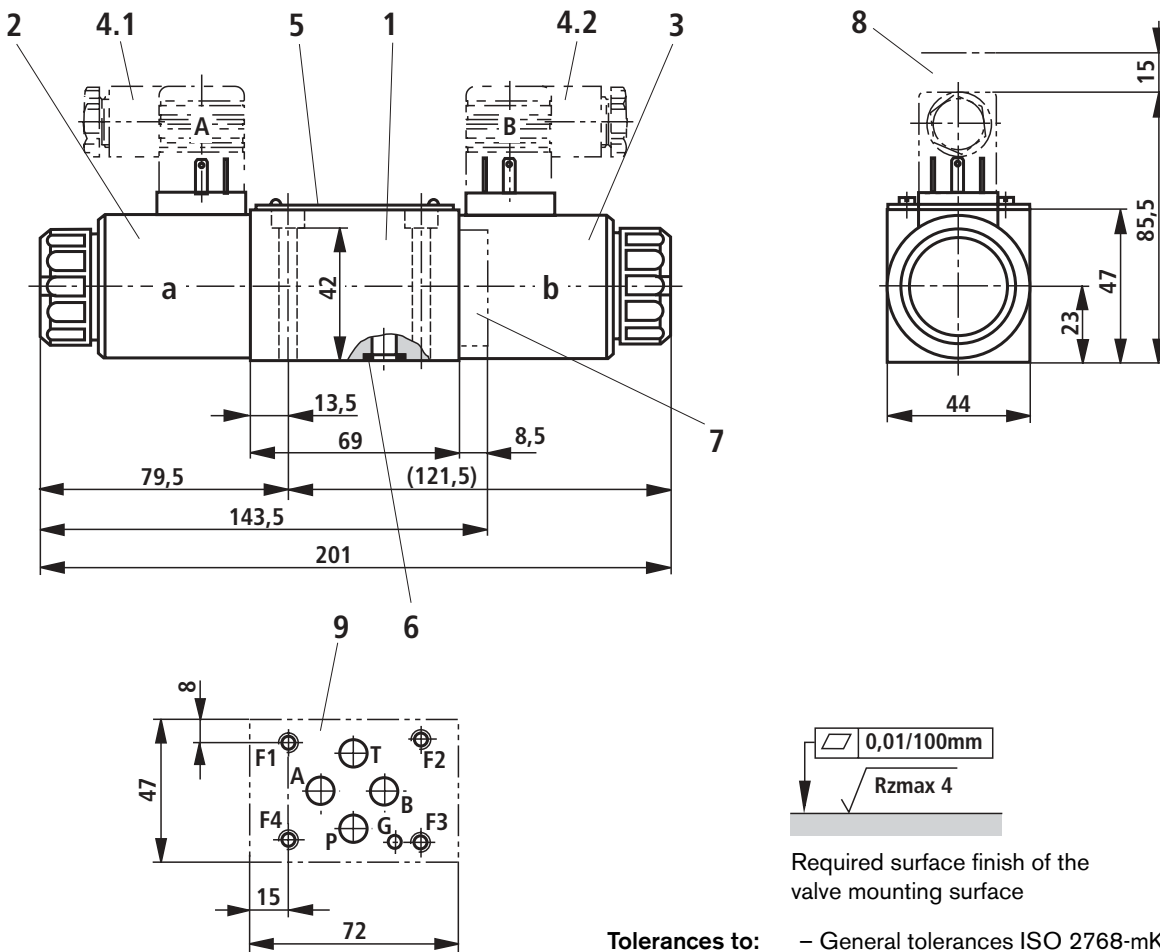

Tolerances to: – General tolerances ISO 2768-mK

- 1 Valve housing
- 2 Proportional solenoid "a"
- 3 Proportional solenoid "b"
- 4.1 Plug-in connector "A", colour grey, separate order, see page 7
- 4.2 Plug-in connector "B", colour black, separate order, see page 7
- 5 Name plate
- 6 Identical seal rings for ports A, B, P and T
- 7 Plug for valves with one solenoid (2 switched positions, versions **EA** or **WA**)
- 8 Space required to remove the plug-in connector
- 9 Machined valve mounting surface, Connection location to ISO 4401 (**with** locating pin hole) Code: 4401-03-02-0-94 (explanation to ISO 5783) Deviation from the standard:
 - without locating pin hole „G“
 - ports P, A, B and T mit $\varnothing 8$ mm

Subplates to catalogue sheet RE 45052 and valve fixing screws must be ordered separately.

Subplates: G341/01 (G1/4)
G342/01 (G3/8)
G502/01 (G1/2)

Valve fixing screws (separate order)

The following valve fixing screws are recommended:

– 4 **S.H.C.S. ISO 4762 - M5 x 50 - 10.9-flZn-240h-L**
(friction value $\mu_{\text{total}} = 0.09$ to 0.14)
Tightening torque $M_A = 7 \text{ Nm} \pm 10\%$
Material No. **R913000064** (separate order)

or

– 4 **S.H.C.S. ISO 4762 - M5 x 50 - 10.9**
(friction value $\mu_{\text{total}} = 0.12$ to 0.17)
Tightening torque $M_A = 8.9 \text{ Nm} \pm 10\%$

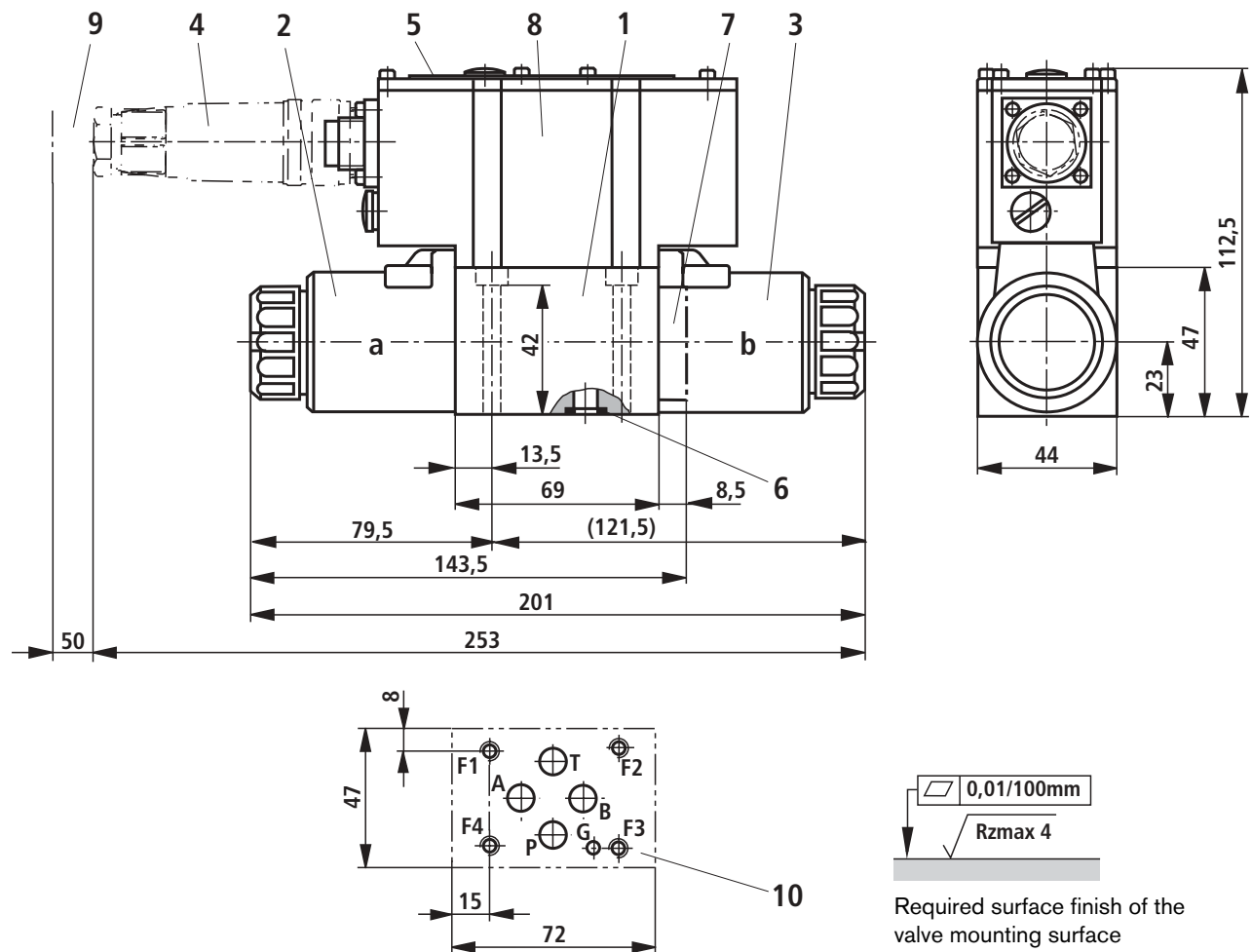
Unit dimensions: Type 4WRAE 6 ...K31/..V (nominal dimensions in mm)
NS6

Tolerance to: – General tolerances to ISO 2768-mK

- 1 Valve housing
- 2 Proportional solenoid "a"
- 3 Proportional solenoid "b"
- 4 Plug-in connector to DIN EN 175201-804, separate order, see page 7
- 5 Name plate
- 6 Identical seal rings for ports A, B, P und T
- 7 Plug for valves with one solenoid (2 switched positions, versions **EA** or **WA**)
- 8 Integrated electronics (OBE)
- 9 Space required for the connection cable and to remove the plug-in connector
- 10 Machined valve mounting surface, Connection location to ISO 4401 (with locating pin hole) Code: 4401-03-02-0-94 (explanation to ISO 5783) Deviation from the standard:
 - without locating pin hole „G“
 - ports P, A, B and T mit $\varnothing 8$ mm

Subplates to catalogue sheet RE 45052 and valve fixing screws must be ordered separately.

Subplates: G341/01 (G1/4)
G342/01 (G3/8)
G502/01 (G1/2)

Valve fixing screws (separate order)

The following valve fixing screws are recommended:

– 4 S.H.C.S. ISO 4762 - M5 x 50 - 10.9-fZn-240h-L

(friction value $\mu_{total} = 0.09$ to 0.14)

Tightening torque $M_A = 7 \text{ Nm} \pm 10\%$

Material No. **R913000064** (separate order)

or

– 4 S.H.C.S. ISO 4762 - M5 x 50 - 10.9

(friction value $\mu_{total} = 0.12$ to 0.17)

Tightening torque $M_A = 8.9 \text{ Nm} \pm 10\%$

Unit dimensions: Type 4WRA 10 (nominal dimensions in mm)

NS10

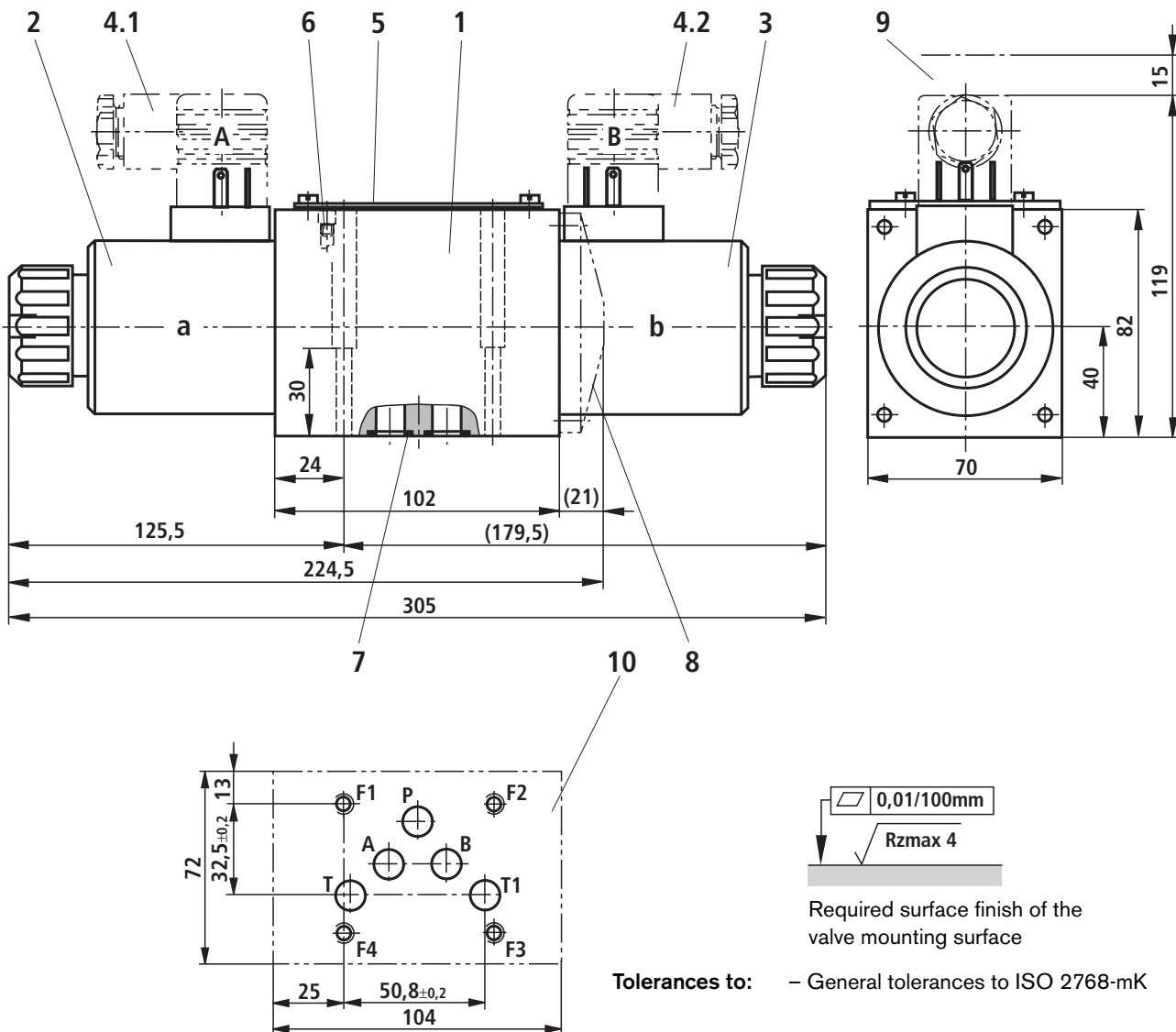

Tolerances to: – General tolerances to ISO 2768-mK

- 1 Valve housing
- 2 Proportional solenoid "a"
- 3 Proportional solenoid "b"
- 4.1 Plug-in connector "A", colour grey, separate order, see page 7
- 4.2 Plug-in connector "B", colour black, separate order, see page 7
- 5 Name plate
- 6 Valve bleed screw
Note: The valves are bled before delivery.
- 7 Identical seal rings for ports A, B, P and T (T1)
- 8 Cover for valves with one solenoid (2 switched positions, versions **EA** or **WA**)
- 9 Space required to remove the plug-in connector
- 10 Machined valve mounting surface, Connection location to ISO 4401 (**with** locating pin hole) Code: 4401-05-04-0-94 (explanation to ISO 5783) Deviation from the standard: Port T1 Ø11.2 mm

Subplates to catalogue sheet RE 45054 and valve fixing screws must be ordered separately.

Subplates: G66/01 (G3/8)
G67/01 (G1/2)
G534/01 (G3/4)

Valve fixing screws (separate order)

The following valve fixing screws are recommended:

– 4 **S.C.H.S. ISO 4762 - M6 x 40 - 10.9-flZn-240h-L**
(friction value $\mu_{\text{total}} = 0.09$ to 0.14)
Tightening torque $M_A = 12.5 \text{ Nm} \pm 10\%$,
Material No. **R913000058** (separate order)

or

– 4 **S.C.H.S. ISO 4762 - M6 x 40 - 10.9**
(friction value $\mu_{\text{total}} = 0.12$ to 0.17)
Tightening torque $M_A = 15,5 \text{ Nm} \pm 10\%$

Unit dimensions: Type 4WRAE 10 (nominal dimensions in mm)

NS10

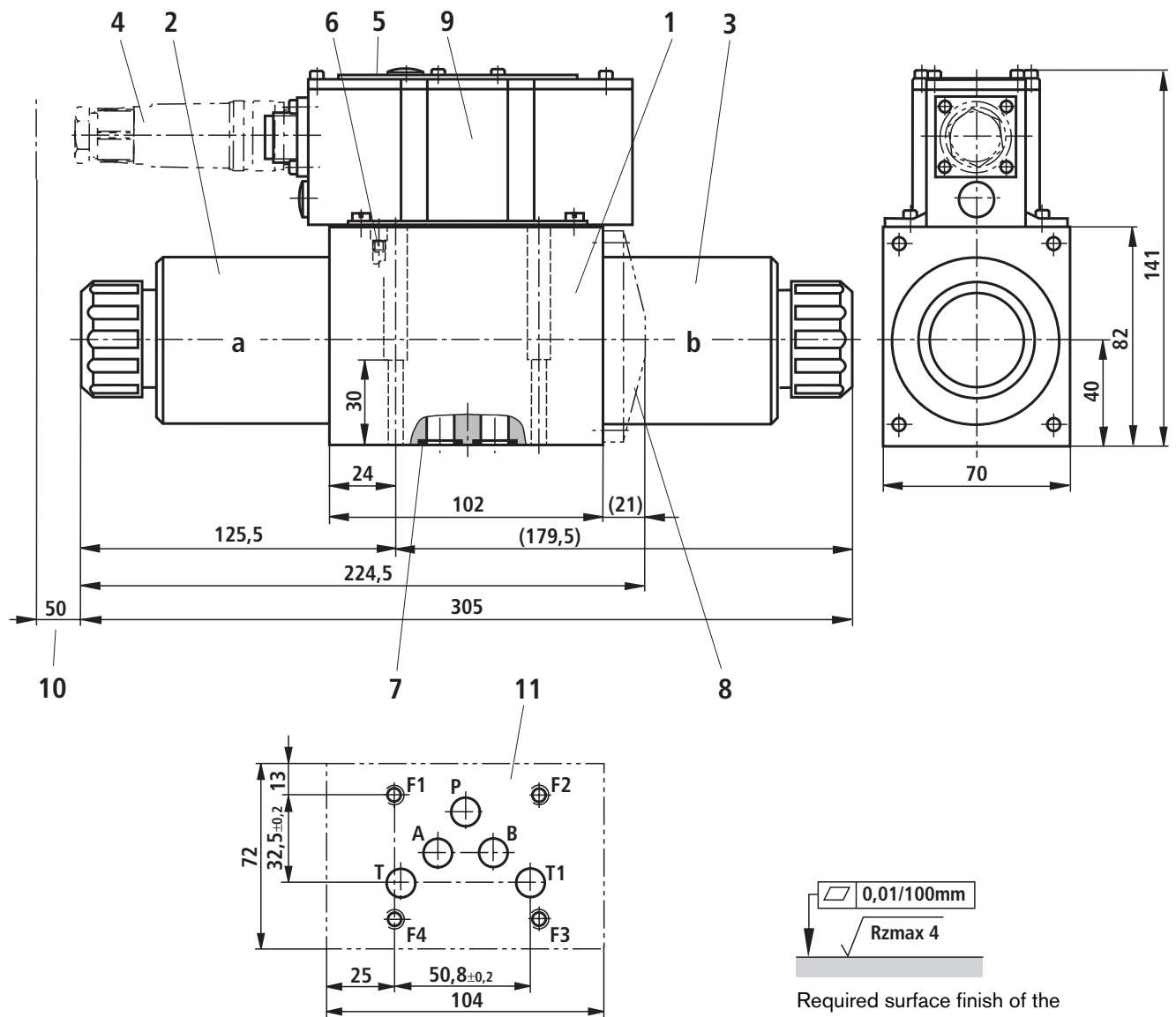

- 1 Valve housing
- 2 Proportional solenoid "a"
- 3 Proportional solenoid "b"
- 4 Plug-in connector to DIN EN 175201-804, separate order, see page 7
- 5 Name plate
- 6 Valve bleed screw
Note: The valves are bled before delivery.
- 7 Identical seal rings for ports A, B, P, T
- 8 Cover for valves with one solenoid (2 switched positions, versions EA or WA)
- 9 Integrated electronics (OBE)
- 10 Space required for the connection cable and to remove the plug-in connector
- 11 Machined valve mounting surface, connection location to ISO 4401 (**with** locating pin hole)
Code: 4401-05-04-0-94 (explanation to ISO 5783)
Deviation from the standard: Port T1 Ø11.2 mm

Tolerances to: – General tolerances to ISO 2768-mK

Subplates to catalogue sheet RE 45054 and valve fixing screws must be ordered separately.

Subplates: G66/01 (G3/8)
G67/01 (G1/2)
G534/01 (G3/4)

Valve fixing screws(separate order)

The following valve fixing screws are recommended:

– **4 S.H.C.S. ISO 4762 - M6 x 40 - 10.9-fZn-240h-L**
(friction value $\mu_{\text{total}} = 0.09$ to 0.14)
Tightening torque $M_A = 12.5 \text{ Nm} \pm 10\%$,
Material No. **R913000058** (separate order)

or

– **4 S.H.C.S. ISO 4762 - M6 x 40 - 10.9**
(friction value $\mu_{\text{total}} = 0.12$ to 0.17)
Tightening torque $M_A = 15,5 \text{ Nm} \pm 10\%$

Notes
