

# Axial piston variable pump A10VO Series 52 and 53



- ▶ For machines with medium pressure requirements
- ▶ Sizes 10 to 100
- ▶ Nominal pressure 250 bar
- ▶ Maximum pressure 315 bar
- ▶ Open circuit

## Features

- ▶ Variable pump with axial piston rotary group in swashplate design for hydrostatic drives in open circuit.
- ▶ Flow is proportional to drive speed and displacement.
- ▶ The flow can be infinitely varied by adjusting the swashplate angle.
- ▶ Stable bearing for long service life
- ▶ High permissible drive speed
- ▶ Favorable power-to-weight ratio – compact dimensions
- ▶ Low noise
- ▶ Excellent suction characteristics
- ▶ Electro-hydraulic pressure control
- ▶ Power control
- ▶ Electro-proportional swivel angle control
- ▶ Short control response times

## Contents

Type code series 52	2
Type code series 53	4
Hydraulic fluids	7
Working pressure range	9
Technical data	10
DR – Pressure controller	12
DRG – Pressure controller, remotely controlled	13
DRF (DFR) / DRS (DFR1) / DRSC – pressure flow controller	14
LA... – Pressure, flow and power controller	16
LA... – Variations	17
ED – Electrohydraulic pressure control	18
ER – Electrohydraulic pressure control	20
EP – Electro-proportional control	21
EK – Electro-proportional control	22
with controller cut-off	22
EP(K).DF / EP(K).DS / EP(K)	23
with pressure flow controller	23
EP.ED / EK.ED with electro-hydraulic pressure control	24
Dimensions, size 10 to 100	25
Dimensions, through drive	62
Overview of mounting options	66
Combination pumps A10VO + A10VO	67
Connector for solenoids	68
Installation instructions	69
Project planning notes	72
Safety instructions	73

## Type code series 52

01	02	03	04	05	06	07	08	09	10	11	12	
<b>A10V(S)</b>	<b>O</b>			<b>/</b>	<b>52</b>		<b>-</b>	<b>V</b>				

### Axial piston unit

									10	28	45	60	85		
01	Swashplate design, variable, nominal pressure 250 bar, maximum pressure 315 bar									●	-	-	-	-	<b>A10VS</b>
										-	●	●	●	●	<b>A10V</b>

### Operating mode

02	Pump, open circuit	<b>O</b>
----	--------------------	----------

### Size (NG)

03	Geometric displacement, see table of values on page 10	<b>10</b>	<b>28</b>	<b>45</b>	<b>60</b>	<b>85</b>
----	--	-----------	-----------	-----------	-----------	-----------

### Control device

04	Pressure controller	hydraulic					●	●	●	●	●	<b>DR</b>	
	with flow controller	hydraulic	X-T open				●	●	●	●	●	<b>DFR</b>	
			X-T plugged				with flushing function	●	●	●	●	●	<b>DFR1</b>
							without flushing function	-	●	●	●	<b>DRSC</b>	
	with pressure cut-off	hydraulic	remote controlled					●	●	●	●	●	<b>DRG</b>
			electric	negative control			$U = 12\text{ V}$	-	●	●	●	●	<b>ED71</b>
							$U = 24\text{ V}$	-	●	●	●	●	<b>ED72</b>
		electric	positive control				$U = 12\text{ V}$	-	●	●	●	●	<b>ER71</b>
						$U = 24\text{ V}$	-	●	●	●	●	●	<b>ER72</b>
		Differential pressure control		electric control (negative control)				-	○	○	○	●	<b>EF..<sup>1)</sup></b>

### Series

05	Series 5, index 2	<b>10</b>	<b>28</b>	<b>45</b>	<b>60</b>	<b>85</b>	●	●	●	●	●	<b>52</b>
----	-------------------	-----------	-----------	-----------	-----------	-----------	---	---	---	---	---	-----------

### Direction of rotation

06	Viewed on drive shaft	clockwise	<b>R</b>
		counter-clockwise	<b>L</b>

### Sealing material

07	FKM (fluoroelastomer)	<b>V</b>
----	-----------------------	----------

### Drive shaft

08	Splined shaft ISO 3019-1	Standard shaft					●	●	●	●	●	<b>S</b>	
		similar to shaft "S" however for higher torque					-	●	●	●	●	<b>R</b>	
		reduced diameter, limited suitability for through drive						●	●	●	●	●	<b>U</b>
		similar to shaft "U", however for higher torque only conditionally suitable for mounting with through drive. For mounting options, see page 66						-	●	●	●	●	<b>W</b>
	Parallel keyed shaft DIN 6885 limited suitability for through drive							●	-	-	-	<b>P</b>	

### Mounting flange

09	ISO 3019-2 (ISO)	2-hole					●	-	-	-	-	<b>A</b>
	ISO 3019-1 (SAE)	2-hole					●	●	●	●	●	<b>C</b>
		4-hole						-	-	-	●	-

<sup>1)</sup> See data sheet 92709 for precise specification

01	02	03	04	05	06	07	08	09	10	11	12
<b>A10V(S)</b>	<b>O</b>			<b>/</b>	<b>52</b>		<b>-</b>	<b>V</b>			

**Working port**

						10	28	45	60	85	
10	SAE flange ports	rear	not for through drive			-	●	●	●	●	<b>11</b>
	Fastening thread metric	laterally opposite	for through drive			-	●	●	●	●	<b>12</b>
		at side, offset 90°	not for through drive; available for counter-clockwise rotation only			-	-	●	-	-	<b>13</b>
	Threaded port metric	rear	not for through drive			●	-	-	-	-	<b>14</b>

**Through drive** (for mounting options, see page 66)

11	Flange ISO 3019-1	Hub for splined shaft <sup>1)</sup>								
	Diameter	Diameter								
	without through drive				●	●	●	●	●	<b>N00</b>
	82-2 (A)	5/8 in	9T 16/32DP		-	●	●	●	●	<b>K01</b>
		3/4 in	11T 16/32DP		-	●	●	●	●	<b>K52</b>
	101-2 (B)	7/8 in	13T 16/32DP		-	●	●	●	●	<b>K68</b>
		1 in	15T 16/32DP		-	-	●	●	●	<b>K04</b>
	127-4 (C)	1 1/4 in	14T 12/24DP		-	-	-	●	●	<b>K15</b>
		1 1/2 in	17T 12/24DP		-	-	-	-	●	<b>K16</b>
	127-2 (C)	1 1/4 in	14T12/24DP		-	-	-	-	●	<b>K07</b>
1 1/2 in		17T 12/24DP		-	-	-	-	●	<b>K24</b>	

**Connector for solenoids**

12	Without connector (without solenoid, only for hydraulic controls, without signs)				●	●	●	●	●	
	DEUTSCH - molded connector, 2-pin, without suppressor diode (for electric control)				-	●	●	●	●	<b>P</b>

● = Available    ○ = On request    - = Not available

**Notice**

- ▶ Observe the general project planning notes on page 72 and the project planning notes regarding each control device.
- ▶ In addition to the type code, please specify the relevant technical data.

1) In accordance with ANSI B92.1a

## Type code series 53

01	02	03	04	05	06	07	08	09	10	11	12
<b>A10V</b>	<b>O</b>			<b>/</b>	<b>53</b>		<b>-</b>	<b>V</b>			

<b>Axial piston unit</b>									<b>18</b>	<b>28</b>	<b>45</b>	<b>63</b>	<b>72</b>	<b>85</b>	<b>100</b>	
01	Swashplate design, variable, nominal pressure 250 bar, maximum pressure 315 bar								•	•	•	•	•	•	•	<b>A10V</b>

<b>Operating mode</b>											
02	Pump, open circuit										<b>O</b>

<b>Size (NG)</b>									<b>18</b>	<b>28</b>	<b>45</b>	<b>63</b>	<b>72</b>	<b>85</b>	<b>100</b>
03	Geometric displacement, see table of values on page 10														

<b>Control device</b>												
04	Pressure controller	hydraulic										<b>DR</b>
	with flow controller	hydraulic	X-T open									<b>DRF</b>
			X-T plugged	with flushing function								<b>DRS</b>
				without flushing function								<b>DRSC</b>
	with pressure cut-off	hydraulic	remote controlled									<b>DRG</b>
		electric	negative control	$U = 12\text{ V}$								<b>ED71</b>
				$U = 24\text{ V}$								<b>ED72</b>
		electric	positive control	$U = 12\text{ V}$								<b>ER71</b>
				$U = 24\text{ V}$								<b>ER72</b>
	Differential pressure control		electric control (negative control)		o	o	o	o	o	•	•	<b>EF..<sup>1)</sup></b>
	Power control with pressure cut-off	hydraulic	Beginning of control	from 10 to 35 bar								<b>LA5D</b>
				36 to 70 bar								<b>LA6D</b>
				71 to 105 bar								<b>LA7D</b>
				106 to 140 bar								<b>LA8D</b>
				141 to 230 bar								<b>LA9D</b>
	remote controlled	hydraulic	Beginning of control	see LA.D								<b>LA.DG</b>
	Flow control X-T plugged	hydraulic with flushing function	Beginning of control	see LA.D								<b>LA.DS</b>
				see LA.D								<b>LA.DC</b>
				see LA.D	o	o	o	o	o	•	•	<b>LA.EF</b>
	Electro-proportional control		positive control									
with pressure control				$U = 12\text{ V}$							<b>EP1D</b>	
				$U = 24\text{ V}$								<b>EP2D</b>
with pressure and flow control (load-sensing)		X-T open		$U = 12\text{ V}$							<b>EP1DF</b>	
				$U = 24\text{ V}$								<b>EP2DF</b>
with pressure and flow control (load-sensing)		X-T plugged		$U = 12\text{ V}$							<b>EP1DS</b>	
				$U = 24\text{ V}$								<b>EP2DS</b>
with electrohydraulic Pressure control				$U = 12\text{ V}$							<b>EP1ED</b>	
				$U = 24\text{ V}$								<b>EP2ED</b>

### Notice

- Observe the project planning notes regarding each control device

<sup>1)</sup> See data sheet 92709 for precise specification

01	02	03	04	05	06	07	08	09	10	11	12
<b>A10V</b>	<b>O</b>			<b>/</b>	<b>53</b>	<b>-</b>	<b>V</b>				

		18 28 45 63 72 85 100								
04	Electro-proportional control	positive control								
	with pressure control	$U = 12 V$						•	<b>EK1D</b>	
		$U = 24 V$						•	<b>EK2D</b>	
	Pressure and flow control with controller	X-T open	$U = 12 V$						•	<b>EK1DF</b>
	cut-off (load sensing)		$U = 24 V$						•	<b>EK2DF</b>
	Pressure and flow control with controller	X-T plugged	$U = 12 V$						•	<b>EK1DS</b>
	cut-off (load sensing)		$U = 24 V$						•	<b>EK2DS</b>
	electrohydraulic pressure control with controller cut-off		$U = 12 V$						•	<b>EK1ED</b>
		$U = 24 V$						•	<b>EK2ED</b>	

**Series**

05	Series 5, index 3	•	•	•	•	•	•	•	•	<b>53</b>
----	-------------------	---	---	---	---	---	---	---	---	-----------

**Direction of rotation**

06	Viewed on drive shaft	clockwise	<b>R</b>
		counter-clockwise	<b>L</b>

**Sealing material**

07	FKM (fluoroelastomer)	<b>V</b>
----	-----------------------	----------

**Drive shaft**

08	Splined shaft ISO3019-1	Standard shaft	•	•	•	•	•	•	•	<b>S</b>
		similar to shaft "S" however for higher torque	•	•	•	•	•	•	•	<b>R</b>
		reduced diameter, limited suitability for through drive	•	•	•	•	•	•	•	<b>U</b>
		similar to shaft "U", however for higher torque only conditionally suitable for mounting with through drive. For mounting options, see page 66	-	•	•	•	•	•	•	<b>W</b>

**Mounting flange**

09	ISO 3019-1 (SAE)	2-hole	•	•	•	•	•	•	•	<b>C</b>
		4-hole	-	-	-	•	•	•	•	<b>D</b>

**Working port**

10	SAE flange ports Fastening thread metric	rear	not for through drive						•	•	•	•	•	•	<b>11</b>
		laterally opposite	for through drive						•	•	•	•	•	•	<b>12</b>
		at side, offset 90°	not for through drive; for counter-clockwise rotation only available						-	-	•	-	-	-	<b>13</b>



01	02	03	04	05	06	07	08	09	10	11	12
<b>A10V</b>	<b>O</b>		<b>/</b>	<b>53</b>		<b>-</b>	<b>V</b>				

**Through drive** (for mounting options, see page 66)

11	Flange ISO 3019-1	Hub for splined shaft <sup>2)</sup>								
	Diameter	Diameter		<b>18</b>	<b>28</b>	<b>45</b>	<b>63</b>	<b>72</b>	<b>85</b>	<b>100</b>
	without through drive			●	●	●	●	●	●	<b>N00</b>
82-2 (A)		5/8 in	9T 16/32DP	●	●	●	●	●	●	<b>K01</b>
		3/4 in	11T 16/32DP	●	●	●	●	●	●	<b>K52</b>
101-2 (B)		7/8 in	13T 16/32DP	-	●	●	●	●	●	<b>K68</b>
		1 in	15T 16/32DP	-	-	●	●	●	●	<b>K04</b>
127-4 (C)		1 1/4 in	14T 12/24DP	-	-	-	●	●	●	<b>K15</b>
		1 1/2 in	17T 12/24DP	-	-	-	-	-	●	<b>K16</b>
127-2 (C)		1 1/4 in	14T12/24DP	-	-	-	-	-	●	<b>K07</b>
		1 1/2 in	17T 12/24DP	-	-	-	-	-	●	<b>K24</b>

**Connector for solenoids**

12	Without connector (without solenoid, only for hydraulic controls, without signs)	●	●	●	●	●	●	●	
	DEUTSCH - molded connector, 2-pin, without suppressor diode (for electric control)	●	●	●	●	●	●	●	<b>P</b>

● = Available    ○ = On request    - = Not available

**Notice**

- ▶ Note the project planning notes on page 72.
- ▶ In addition to the type code, please specify the relevant technical data when placing your order.

<sup>2)</sup> In accordance with ANSI B92.1a

## Hydraulic fluids

The A10VO variable pump is designed for operation with HLP mineral oil according to DIN 51524.

See the following data sheets for application instructions and requirements for hydraulic fluids before the start of project planning:

- ▶ 90220: Hydraulic fluids based on mineral oils and related hydrocarbons
- ▶ 90221: Environmentally acceptable hydraulic fluids

### Selection of hydraulic fluid

Bosch Rexroth evaluates hydraulic fluids on the basis of the Fluid Rating according to the technical data sheet 90235.

Hydraulic fluids with positive evaluation in the Fluid Rating are provided in the following technical data sheet:

- ▶ 90245: Bosch Rexroth Fluid Rating List for Rexroth hydraulic components (pumps and motors)

The hydraulic fluid should be selected so that the operating viscosity in the operating temperature range is within the optimum range ( $v_{opt}$ ; see selection diagram).

### Viscosity and temperature of hydraulic fluids

	Viscosity	Shaft seal	Temperature <sup>2)</sup>	Remarks
Cold start	$v_{max} \leq 1600 \text{ mm}^2/\text{s}$	FKM	$\vartheta_{st} \geq -25 \text{ }^\circ\text{C}$	$t \leq 3 \text{ min}$ , without load ( $p \leq 50 \text{ bar}$ ), $n \leq 1000 \text{ rpm}$ Permissible temperature difference between axial piston unit and hydraulic fluid in the system maximum 25 K
Warm-up phase	$v = 1600 \dots 400 \text{ mm}^2/\text{s}$			$t \leq 15 \text{ min}$ , $p \leq 0.7 \times p_{nom}$ and $n \leq 0.5 \times n_{nom}$
Continuous operation	$v = 400 \dots 10 \text{ mm}^2/\text{s}^{1)}$ $v_{opt} = 36 \dots 16 \text{ mm}^2/\text{s}$	FKM	$\vartheta \leq +110 \text{ }^\circ\text{C}$	Measured at port <b>L<sub>x</sub></b> Optimal operating viscosity and efficiency range
Short-term operation	$v_{min} = 10 \dots 7 \text{ mm}^2/\text{s}$	FKM		$t \leq 3 \text{ min}$ , $p \leq 0.3 \times p_{nom}$ , measured at port <b>L<sub>x</sub></b>

### ▼ Selection diagram

Maximum permissible viscosity on cold start

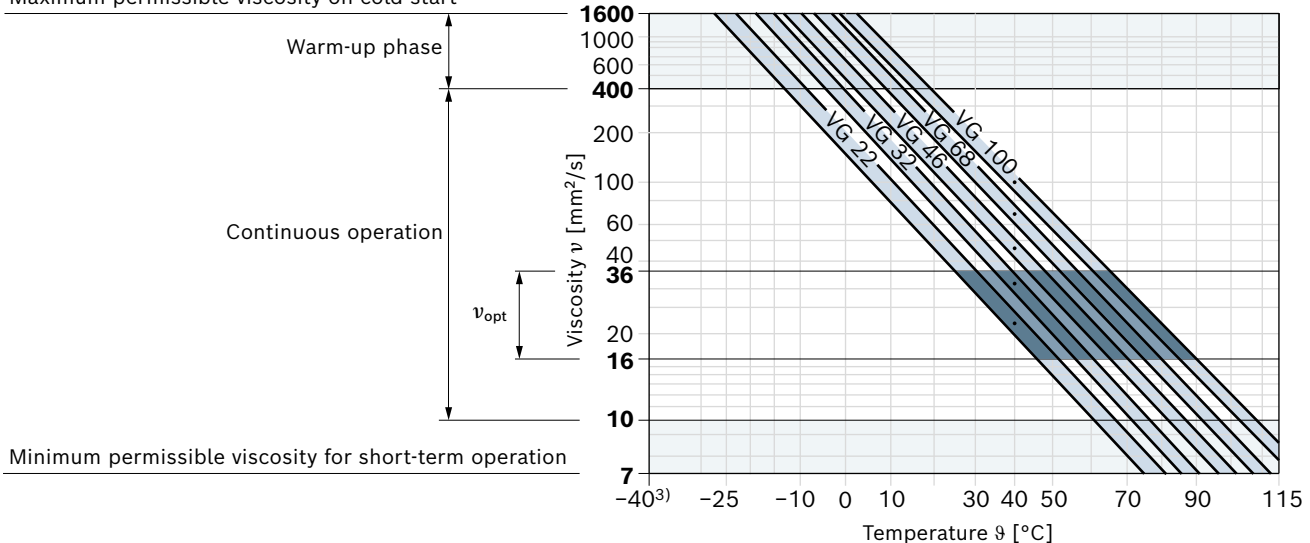

1) This corresponds, for example on the VG 46, to a temperature range of +4 °C to +85 °C (see selection diagram)

2) If the temperature at extreme operating parameters cannot be adhered to, please contact us.

3) For applications in the low-temperature range, please contact us.

### **Filtration of the hydraulic fluid**

Finer filtration improves the cleanliness level of the hydraulic fluid, which increases the service life of the axial piston unit.

A cleanliness level of at least 20/18/15 is to be maintained according to ISO 4406

At a hydraulic fluid viscosity of less than 10 mm<sup>2</sup>/s (e.g. due to high temperatures during short-term operation),

at the drain port, a cleanliness level of at least 19/17/14 under ISO 4406 is required.

For example, viscosity corresponds to 10 mm<sup>2</sup>/s at:

- HLP 32 a temperature of 73°C
- HLP 46 a temperature of 85 °C

## Working pressure range

Pressure at working port B		Definition
Nominal pressure $p_{nom}$	250 bar	The nominal pressure corresponds to the maximum design pressure.
Maximum pressure $p_{max}$	315 bar	The maximum pressure corresponds to the maximum working pressure within a single operating period. The sum of single operating periods must not exceed the total operating period.
Single operating period	2.5 ms	
Total operating period	300 h	
Minimum pressure $p_{B abs}$ (high-pressure side)	10 bar	Minimum pressure on the high-pressure side (B) which is required in order to prevent damage to the axial piston unit.
Rate of pressure change $R_{A max}$	16000 bar/s	Maximum permissible pressure build-up and reduction speed during a pressure change across the entire pressure range.
Pressure at suction port S (inlet)		
Minimum pressure $p_{S min}$	Standard 0.8 bar abs.	Minimum pressure at suction port S (inlet) which is required to prevent damage to the axial piston unit. The minimum pressure depends on the rotational speed and displacement of the axial piston unit.
Maximum pressure $p_{S max}$	5 bar abs.	
Leakage pressure at port L, L <sub>1</sub> , L <sub>2</sub>		
Maximum pressure $p_{L max}$	2 bar	Maximum 0.5 bar higher than inlet pressure at port S, but not higher than $p_{L max}$ . The leakage pressure must always exceed the ambient pressure. A case drain line to the reservoir is required.
Pilot pressure port X with external high pressure		
Maximum pressure $p_{max}$	315 bar	When designing all control lines with external high pressure, the values for the rate of pressure change, maximum single operating period and total operating period applicable to port B must not be exceeded.

### Notice

Working pressure range applies when using hydraulic fluids based on mineral oils. Please contact us for values for other hydraulic fluids.

### ▼ Maximum permissible rotational speed (speed limit)

Permissible speed by increasing inlet pressure  $p_{abs}$  at suction opening S or at  $V_g \leq V_{gmax}$

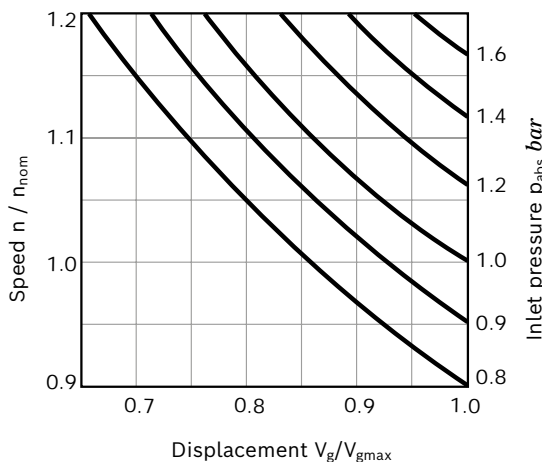

### ▼ Pressure definition

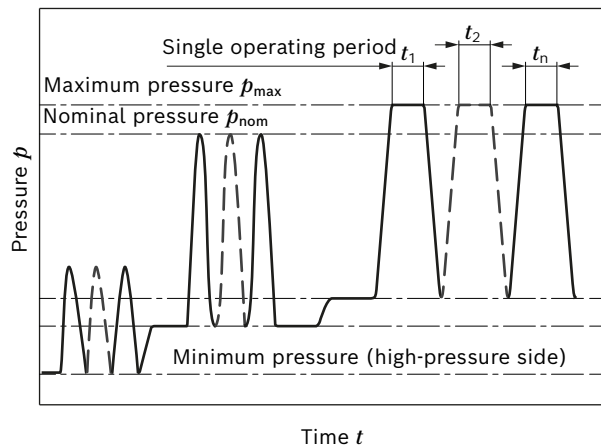

Total operating period =  $t_1 + t_2 + \dots + t_n$

### ▼ Rate of pressure change $R_{A max}$

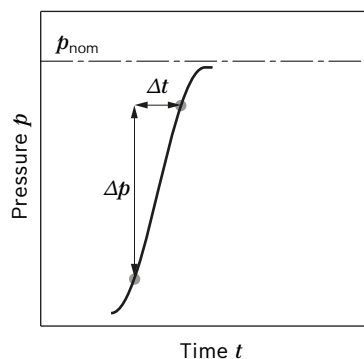

## Technical data

Size	NG		10	18	28	45	60	63	72	85	100	
Displacement geometric, per revolution	$V_{g \max}$	cm <sup>3</sup>	10.5	18	28	45	60	63	72	85	100	
Rotational speed maximum <sup>1)</sup>	at $V_{g \max}$	$n_{\text{nom}}$	rpm	3600	3300	3000	2600 <sup>4)</sup>	2700	2600	2600	2500	2300
	at $V_g < V_{g \max}$ <sup>2)</sup>	$n_{\text{max adm.}}$	rpm	4320	3960	3600	3120	3140	3140	3140	3000	2500
Flow	at $n_{\text{nom}}$ and $V_{g \max}$	$q_v$	l/min	37	59	84	117	162	163	187	212	230
	at $n_E = 1500$ rpm	$q_{vE}$	l/min	15	27	42	68	90	95	108	128	150
Power	with $n_{\text{nom}}$ , $V_{g \max}$ and $\Delta p = 250$ bar	$P$	kW	16	25	35	49	65	68	77	89	96
	at $n_E = 1500$ rpm	$P_E$	kW	7	11	18	28	37	39	45	53	62
Torque	at $V_{g \max}$ and $\Delta p = 250$ bar	$M$	Nm	42	71	111	179	238	250	286	338	398
	at $V_{g \max}$ and $\Delta p = 100$ bar	$M$	Nm	17	29	45	72	95	100	114	135	159
Rotary stiffness	S	$c$	Nm/rad	9200	11000	22300	37500	65500	65500	65500	143000	143000
Drive shaft	R	$c$	Nm/rad	–	14800	26300	41000	69400	69400	69400	152900	152900
	U	$c$	Nm/rad	6800	8000	16700	30000	49200	49200	49200	102900	102900
	W	$c$	Nm/rad	–	–	19900	34400	54000	54000	54000	117900	117900
	P	$c$	Nm/rad	10700	–	–	–	–	–	–	–	–
Moment of inertia of the rotary group	$J_{TW}$	kgm <sup>2</sup>	0.0006	0.0009	0.0017	0,003	0.0056	0.0056	0.0056	0,012	0,012	
Maximum angular acceleration <sup>3)</sup>	$\alpha$	rad/s <sup>2</sup>	8000	6800	5500	4000	3300	3300	3300	2700	2700	
Case volume	$V$	l	0.2	0.25	0.3	0.5	0.8	0.8	0.8	1	1	
Weight <b>without</b> through drive (approx.)	$m$	kg	8	11.5	15	18	22	22	22	36	36	
Weight <b>with</b> through drive (approx.)			–	13	18	24	28	28	28	45	45	

Determination of the characteristics		
Flow	$q_v = \frac{V_g \times n \times \eta_v}{1000}$	[l/min]
Torque	$M = \frac{V_g \times \Delta p}{20 \times \pi \times \eta_{hm}}$	[Nm]
Power	$P = \frac{2 \pi \times M \times n}{60000} = \frac{q_v \times \Delta p}{600 \times \eta_t}$	[kW]

### Key

- $V_g$  Displacement per revolution [cm<sup>3</sup>]
- $\Delta p$  Differential pressure [bar]
- $n$  Rotational speed [rpm]
- $\eta_v$  Volumetric efficiency
- $\eta_{hm}$  Hydraulic-mechanical efficiency
- $\eta_t$  Total efficiency ( $\eta_t = \eta_v \times \eta_{hm}$ )

### Notice

- Theoretical values, without efficiency and tolerances; values rounded
- Operation above the maximum values or below the minimum values may result in a loss of function, a reduced service life or in the destruction of the axial piston unit. Bosch Rexroth recommends checking the load by means of experiment or calculation / simulation and comparison with the permissible values.

1) The values are applicable:  
 – At an abs. pressure  $p_{\text{abs}} = 1$  bar at the suction port **S**  
 – for the optimum viscosity range from  $\nu_{\text{opt}} = 36$  to  $16$  mm<sup>2</sup>/s  
 – with hydraulic fluid on the basis of mineral oils

2) See diagram on page 9 at speed increase up to  $n_{\text{max adm.}}$ .

3) The data are valid for values between the minimum required and maximum permissible rotational speed. It applies for external stimuli (e.g. diesel engine 2 to 8 times rotary frequency, cardan shaft twice the rotary frequency). The limit value is only valid for a single pump. The load capacity of the connection parts must be considered.

**Permissible radial and axial loading of the drive shaft**

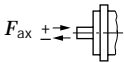
Size	NG	10	18	28	45	60/63	72	85	100	
Maximum radial force at $a/2$	 $F_{q \max}$	N	250	350	1200	1500	1700	1500	2000	2000
Maximum axial force	 $F_{ax \max}$	N	400	700	1000	1500	2000	1500	3000	3000

**Notice**

- The values given are maximum values and do not apply to continuous operation. All loads of the drive shaft reduce the bearing service life.

**Permissible input and through-drive torques**

Size		10	18	28	45	60/63	72	85	100		
Torque at $V_{g \max}$ and $\Delta p = 250 \text{ bar}^1$	$M_{\max}$	Nm	42	71	111	179	250	321	338	398	
Maximum input torque on drive shaft <sup>2)</sup>											
	S	$M_{E \max}$	Nm	126	124	198	319	630	630	1157	1157
		$\emptyset$	in	3/4	3/4	7/8	1	1 1/4	1 1/4	1 1/2	1 1/2
	R	$M_{E \max}$	Nm	–	160	250	400	650	650	1215	1215
		$\emptyset$	in	–	3/4	7/8	1	1 1/4	1 1/4	1 1/2	1 1/2
	U	$M_{E \max}$	Nm	60	59	105	188	306	306	628	628
		$\emptyset$	in	5/8	5/8	3/4	7/8	1	1	1 1/4	1 1/4
	W	$M_{E \max}$	Nm	–	–	140	220	396	383	650	650
		$\emptyset$	in	–	–	3/4	7/8	1	1	1 1/4	1 1/4
	P	$M_{E \max}$	Nm	90	–	–	–	–	–	–	–
		$\emptyset$	mm	18	–	–	–	–	–	–	–
Maximum through-drive torque											
	S	$M_{D \max}$	Nm	–	108	160	319	484	484	698	698
	R	$M_{D \max}$	Nm	–	120	176	365	484	484	698	–
	U	$M_{D \max}$	Nm	–	59	105	188	306	306	628	628
	W	$M_{D \max}$	Nm	–	–	140	220	396	383	650	650

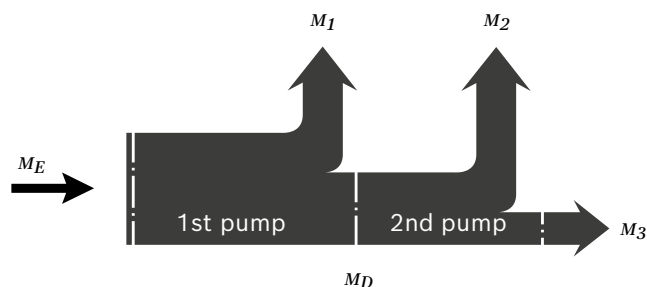
**▼ Distribution of torques**

Torque at 1st pump	$M_1$
Torque at 2nd pump	$M_2$
Torque at 3rd pump	$M_3$
Input torque	$M_E = M_1 + M_2 + M_3$
	$M_E < M_{E \max}$
Through-drive torque	$M_D = M_2 + M_3$
	$M_D < M_{D \max}$

1) Efficiency not considered

2) For drive shafts with no radial force

## DR – Pressure controller

The pressure controller limits the maximum pressure at the pump outlet within the control range of the variable pump. The variable pump only supplies as much hydraulic fluid as is required by the consumers. If the working pressure exceeds the pressure command value at the pressure valve, the pump will regulate to a smaller displacement to reduce the control differential.

- ▶ Basic position in depressurized state:  $V_{g \max}$ .
- ▶ Setting range<sup>1)</sup> for pressure control 35 to 250 bar. Standard is 250 bar.

### ▼ Characteristic curve DR

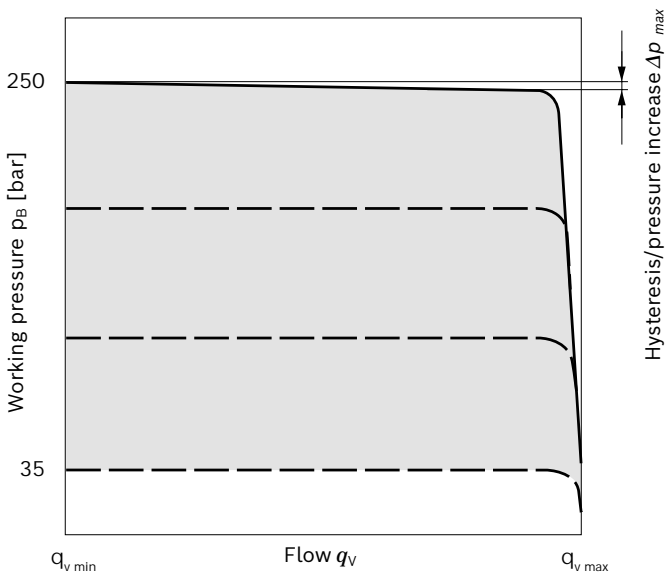

Characteristic curve valid for  $n_1 = 1500$  rpm and  $\vartheta_{\text{fluid}} = 50$  °C.

### ▼ Circuit diagram DR

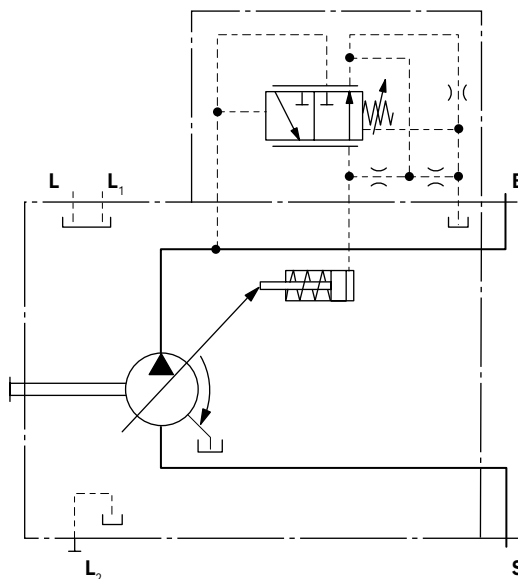

### Controller data

Size		10	18	28	45	60	72	85	100	
						63				
Pressure increase	$\Delta p$ [bar]	6	6	6	6	8	8	12	14	
Hysteresis and Repeat accuracy	$\Delta p$ [bar]	maximum 3								
Pilot fluid consumption	l/min	maximum approx. 3								

<sup>1)</sup> In order to prevent damage to the pump and the system, the permissible setting range must not be exceeded. The range of possible settings at the valve is higher.

## DRG – Pressure controller, remotely controlled

For the remote controlled pressure controller, the LS pressure limitation is performed using a separately arranged pressure relief valve. Therefore, any pressure control value under the pressure set on the pressure controller can be regulated. Pressure controller DR see page 12.

A pressure relief valve is externally piped to port **X** for remote control. This relief valve is not included in the scope of delivery of the DRG control.

When there is differential pressure  $\Delta p$  at the control valve and with the standard setting on the remote controlled pressure cut-off of 20 bar, the amount of control fluid at the port is **X** approx. 1.5 l/min. If another setting is required (range from 10-22 bar) please state in plain text.

As a separate pressure relief valve (**1**) we recommend:

- ▶ a direct operated, hydraulic or electric proportional one, suitable for the control fluid mentioned above.

The maximum line length should not exceed 2 m.

- ▶ Basic position in depressurized state:  $V_{g \max}$ .
- ▶ Setting range<sup>1)</sup> for pressure control 35 to 250 bar (**3**). Standard is 250 bar.
- ▶ Setting range for differential pressure 10 up to 22 bar (**2**). Standard is 20 bar.

Unloading on port **X** to the reservoir results in a zero stroke pressure ("standby") pressure which lies about 1 to 2 bar higher than the differential pressure  $\Delta p$ , however, other system influences are not taken into account.

### ▼ Characteristic curve DRG

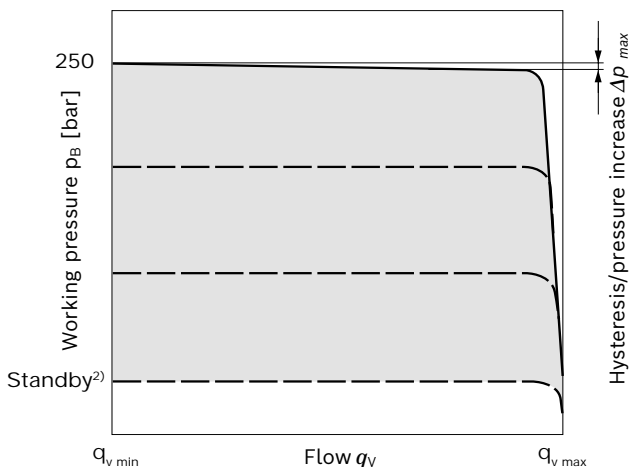

Characteristic curve valid for  $n_1 = 1500$  rpm and  $\vartheta_{\text{fluid}} = 50$  °C.

### ▼ Circuit diagram DRG

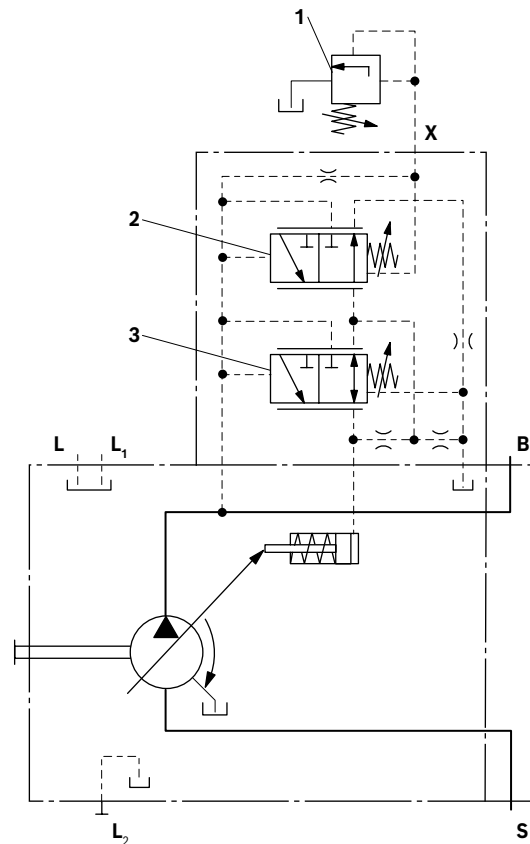

- 1** The separate pressure relief valve and the line are not included in the scope of delivery.
- 2** Remote controlled pressure cut-off (**G**)
- 3** Pressure controller (**DR**)

### Controller data

Size	10	18	28	45	60 63	72	85	100	
Pressure increase	$\Delta p$ [bar]	6	6	6	6	8	8	12	14
Hysteresis and Repeat accuracy	$\Delta p$ [bar]	maximum 3							
Pilot fluid consumption	l/min	maximum approx. 4.5							

- <sup>1)</sup> In order to prevent damage to the pump and the system, the permissible setting range must not be exceeded. The range of possible settings at the valve is higher.
- <sup>2)</sup> Zero stroke pressure from pressure setting  $\Delta p$  on controller (**2**)

## DRF (DFR) / DRS (DFR1) / DRSC – pressure flow controller

In addition to the pressure controller function (see page 12), an adjustable orifice (e.g. directional valve) is used to adjust the differential pressure upstream and downstream of the orifice. This is used to control the pump flow. The pump flow is equal to the actual hydraulic fluid quantity required by the consumer. With all controller combinations, the  $V_g$  reduction has priority.

- ▶ Basic position in depressurized state:  $V_{g \max}$ .
- ▶ Setting range<sup>1)</sup> to 250 bar.
- ▶ DR pressure controller data see page 12

### ▼ Characteristic curve DRF (DFR) / DRS (DFR1) / DRSC

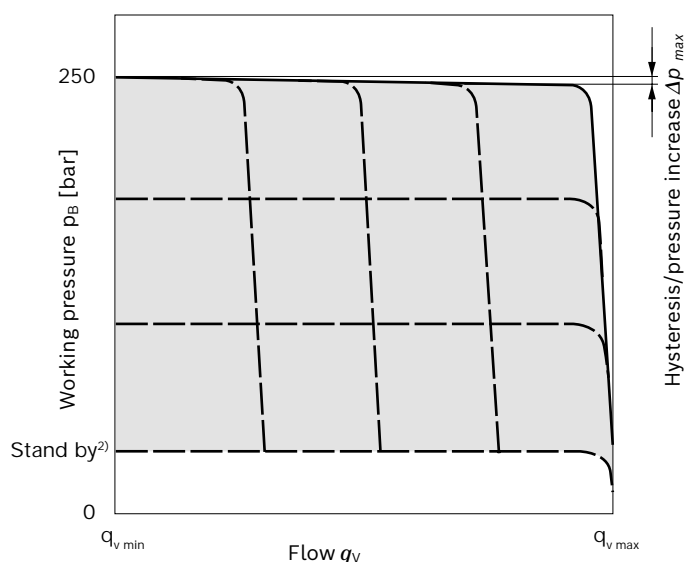

### ▼ Characteristic curve at variable rotational speed

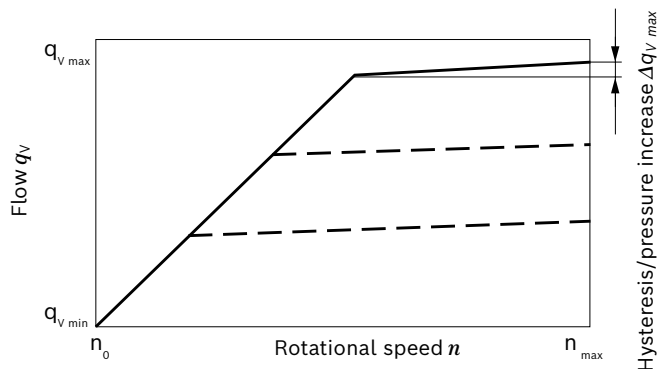

Characteristic curves valid for  $n_1 = 1500$  rpm and  $\vartheta_{\text{fluid}} = 50$  °C.

- 1) In order to prevent damage to the pump and the system, the permissible setting range must not be exceeded. The range of possible settings at the valve is higher.
- 2) Zero stroke pressure from differential pressure setting  $\Delta p$  on controller (2)

Connection options at port **B**  
(not included in the scope of delivery)

LS mobile control blocks	Data sheets
M4-12	64276
M4-15	64283
LUDV mobile control blocks	
M6-15	64284
M7-22	64295

### ▼ Circuit diagram DRF (DFR)

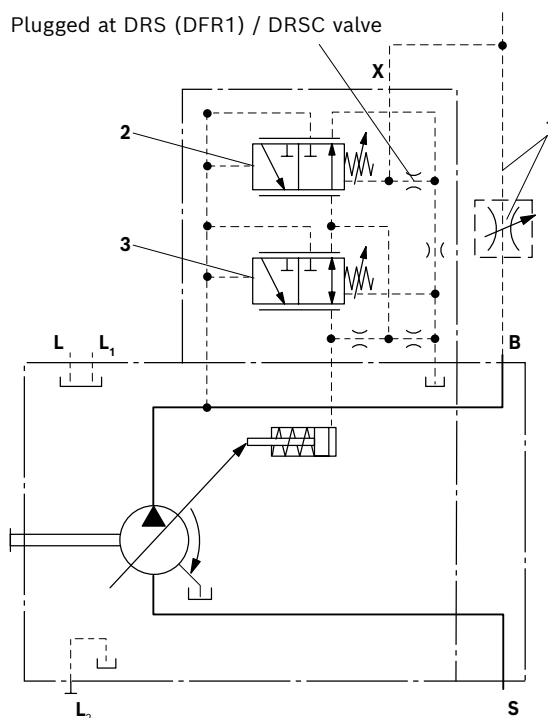

- 1 The metering orifice (control block) and the line are not included in the scope of delivery.
- 2 Flow controller (FR).
- 3 Pressure controller (DR)

#### Notice

The DRS (DFR1) and DRSC versions have no unloading from **X** to the reservoir.

The LS must thus be unloaded in the system.

Because of the flushing function sufficient unloading of the flow controller in DRS (DFR1) control valve **X**-line must also be provided.

If this unloading of the **X** line cannot be ensured, the DRSC control valve must be used.

For further information see page 15

**Differential pressure  $\Delta p$ :**

- ▶ Standard setting: 14 bar  
 If another setting is required, please state in clear text.
- ▶ Setting range: 14 bar to 22 bar

Unloading on port **X** to the reservoir results in a zero stroke pressure ("standby") pressure which lies about 1 to 2 bar higher than the differential pressure  $\Delta p$ , however, other system influences are not taken into account.

**Controller data**

- ▶ DR pressure controller data see page 12
- ▶ Maximum flow deviation measured at drive speed  $n = 1500$  rpm.

Size		10	18	28	45	60	72	85	100
						<b>63</b>			
Flow deviation	$\Delta q_{vmax}$ [l/min]	0.5	0.9	1.0	1.8	2.5	2.5	3.1	3.1
Hysteresis; Repeat accuracy	$\Delta p$ [bar]	maximum 3							
Pilot fluid consumption	l/min	maximum approx. 3 to 4.5 (DRF (DFR)) maximum approx. 3 (DRS (DFR1) / DRSC)							

## LA... – Pressure, flow and power controller

Pressure controller equipped as DR(G), see page 12 (13).

Equipment of the flow controller like DRS (DFR1), see page 14.

In order to achieve a constant drive torque with varying operating pressures, the swivel angle and with it the volume flow from the axial piston pump is varied so that the product of flow and pressure remains constant.

Flow control is possible below the power control curve. When ordering please state the power characteristics to be set ex works in plain text, e.g. 20 kW at 1500 rpm.

### Controller data

- ▶ Pressure controller DR see page 12.
- ▶ Pressure and flow controller DR see page 14.
- ▶ See data sheet 92709 for electric override LA.EF
- ▶ Pilot fluid consumption max. approx. 5.5 l/min.

Beginning of control	Torque $M$ [Nm] for size							Order code
	18	28	45	63	72	85	100	
10 to 35 bar	3.8 – 12.1	6 – 19	10 – 30	15 – 43	17 – 49.2	20 – 57	24 – 68	<b>LA5</b>
36 to 70	12.2 – 23.3	19.1 – 36	30.1 – 59	43.1 – 83	49.3 – 94.9	57.1 – 112	68.1 – 132	<b>LA6</b>
71 to 105	23.4 – 33.7	36.1 – 52	59.1 – 84	83.1 – 119	95.0 – 136.0	112.1 – 160	132.1 – 189	<b>LA7</b>
106 to 140	33.8 – 45	52.1 – 70	84.1 – 112	119.1 – 157	136.1 – 179.4	160.1 – 212	189.1 – 249	<b>LA8</b>
141 – 230	45.1 – 74.8	70.1 – 117	112.1 – 189	157.1 – 264	179.5 – 301.7	212.1 – 357	249.1 – 419	<b>LA9</b>

Conversion of the torque values in power [kW]

$$P = \frac{M}{6.4} \text{ [kW]} \quad (\text{At 1500 rpm})$$

$$\text{or} \quad P = \frac{2\pi \times M \times n}{60000} \text{ [kW]} \quad (\text{For rotational speeds see page 10})$$

### ▼ Characteristic curve LA.DS

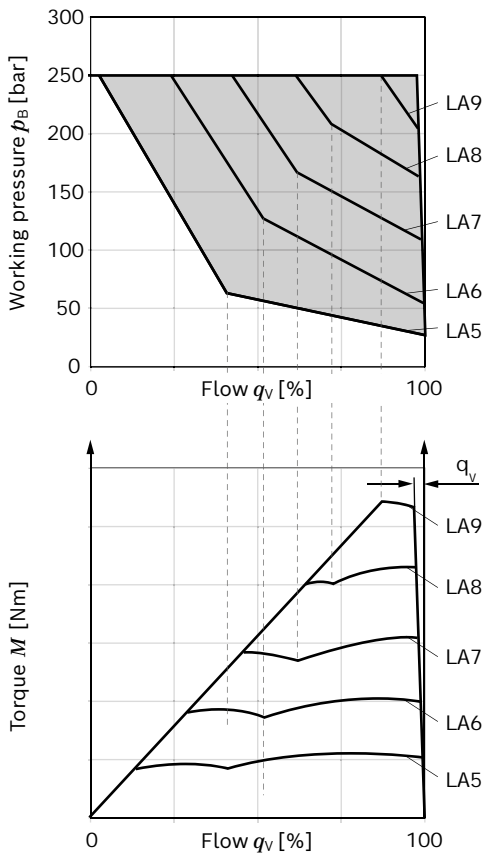

### ▼ Circuit diagram LA.DS

(for further combination options with LA.. see page 17)

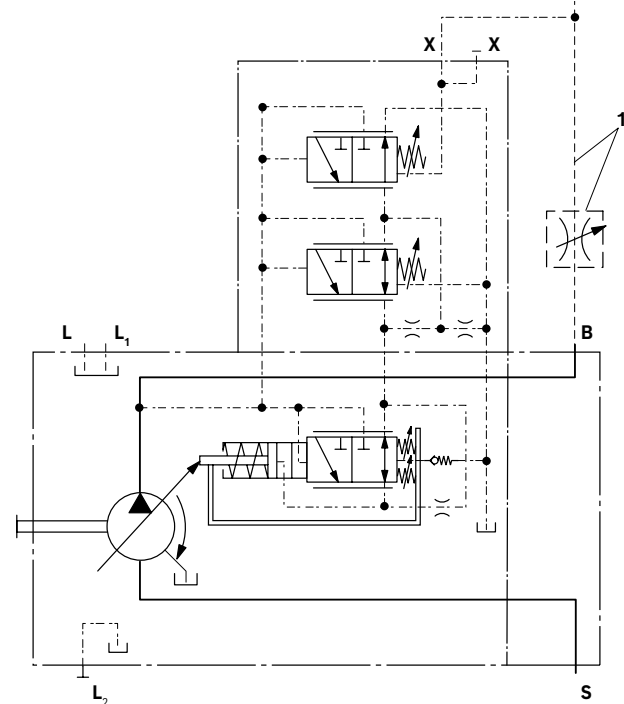

- 1 The metering orifice (control block) and the line are not included in the scope of delivery.

## LA... – Variations

▼ **Circuit diagram LA.D with pressure cut-off**

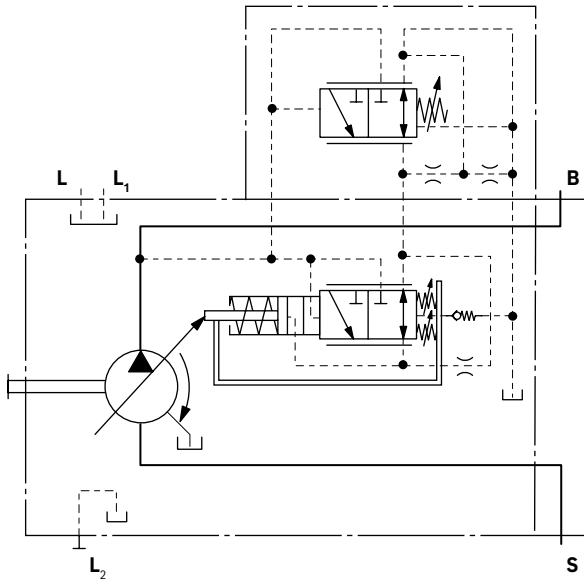

▼ **Circuit diagram LA.DG with pressure cut-off, remotely controlled**

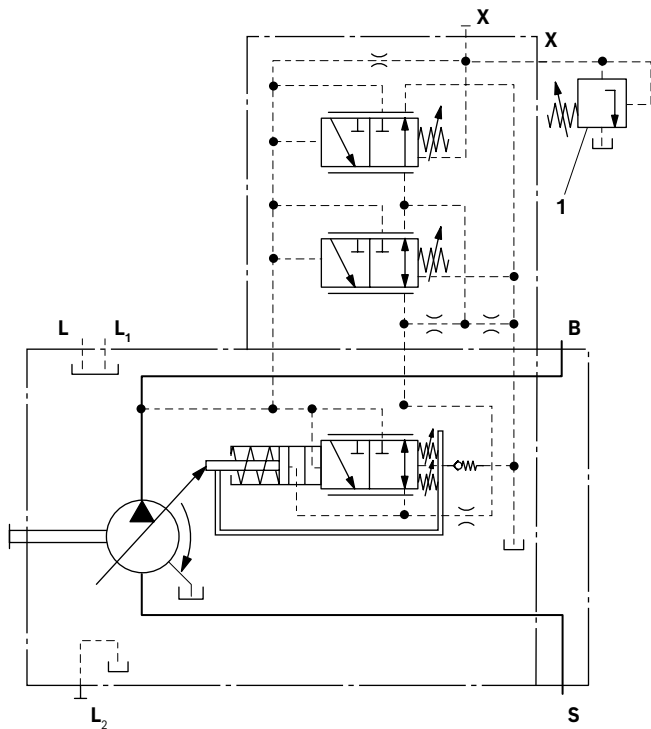

**1** The pressure relief valve and the line are not included in the scope of delivery.

## ED – Electrohydraulic pressure control

The ED valve is set to a certain pressure by a specified variable solenoid current.

When changing the consumer (load pressure), this causes an increase or decrease in the pump swivel angle (flow) in order to maintain the electrically set pressure level.

The pump thus only delivers as much hydraulic fluid as the consumers can take. The desired pressure level can be set steplessly by varying the solenoid current.

As the solenoid current signal drops towards zero, the pressure will be limited to  $p_{max}$  by an adjustable hydraulic pressure cut-off (secure fail safe function in case of power failure, e.g. for fan speed control). The swivel time characteristic of the ED control was optimized for the use as a fan drive system.

When ordering, specify the type of application in plain text.

### ▼ Current/pressure characteristic curve ED

(negative characteristic curve, measured with pump in zero stroke)

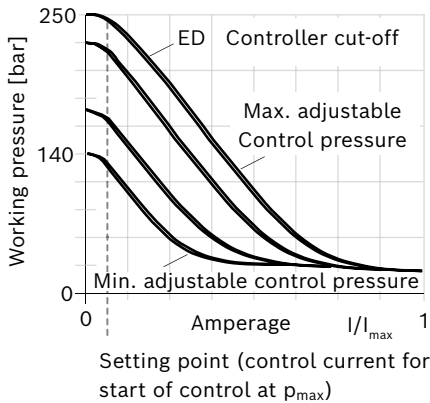

- ▶ Hysteresis static < 3 bar.

### ▼ Flow-pressure characteristic curve

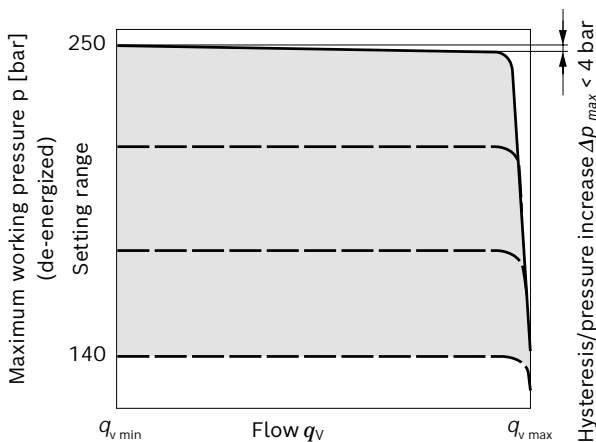

- ▶ Characteristic curves valid for  $n_1 = 1500 \text{ rpm}$  and  $\vartheta_{fluid} = 50 \text{ }^\circ\text{C}$ .

- ▶ Pilot fluid consumption: 3 to 4.5 l/min.
- ▶ For standby standard setting, see the following diagram, other values on request

### ▼ Influence of the pressure setting on standby (maximum energization)

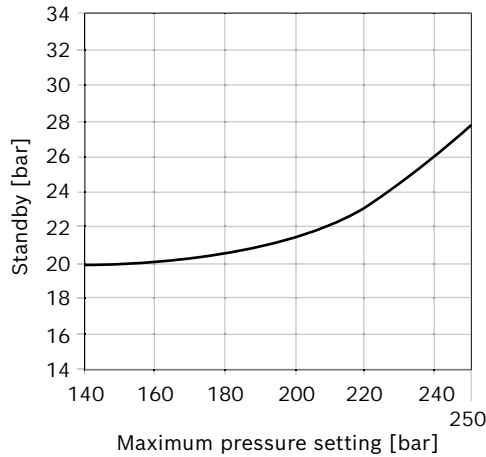

### ▼ Circuit diagram ED71/ED72

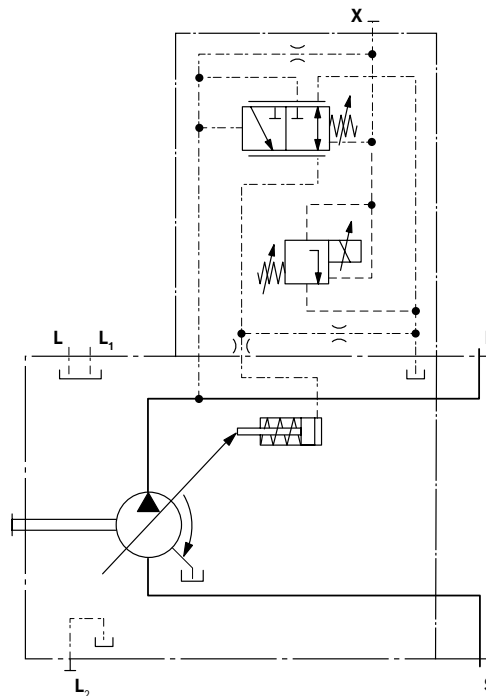

Technical data, solenoids	ED71	ED72
Voltage	12 V ( $\pm 20\%$ )	24 V ( $\pm 20\%$ )
Control current		
Start of control at $p_{\max}$	100 mA	50 mA
End of control at $p_{\min}$	1200 mA	600 mA
Current limit	1.54 A	0.77 A
Nominal resistance (at 20 °C)	5.5 $\Omega$	22.7 $\Omega$
Dither frequency	100 Hz	100 Hz
Recommended amplitude Peak to peak <sup>1)</sup>	240 mA	120 mA
Duty cycle	100%	100%
Type of protection: see connector version page 13		
Operating temperature range at valve -20 °C to +115 °C		

#### Notice!

With **ED71**, de-energized operating condition (jump from 100 to 0 mA) results in a pressure increase of the maximum pressure of 4 to 5 bar.

With **ED72**, de-energized operating condition (jump from 50 to 0 mA) results in a pressure increase of the maximum pressure of 4 to 5 bar.

1)  $\Delta I$  = 44% of the current difference within the control range, regardless of the mean value of the current

## ER – Electrohydraulic pressure control

The ER valve is set to a certain pressure by a specified variable solenoid current.

When changing the consumer (load pressure), this causes an increase or decrease in the pump swivel angle (flow) in order to maintain the electrically set pressure level.

The pump thus only delivers as much hydraulic fluid as the consumers can take. The desired pressure level can be set steplessly by varying the solenoid current.

As the solenoid current signal drops towards zero, the pressure will be limited to  $p_{\min}$  (stand by).

**Observe project planning notes.**

### ▼ Current/pressure characteristic curve ED

(positive characteristic curve measured with pump in zero stroke)

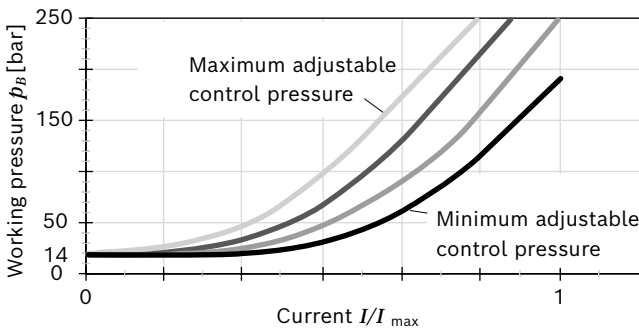

- ▶ Hysteresis static current-pressure characteristic curve < 3 bar.

### ▼ Flow-pressure characteristic curve

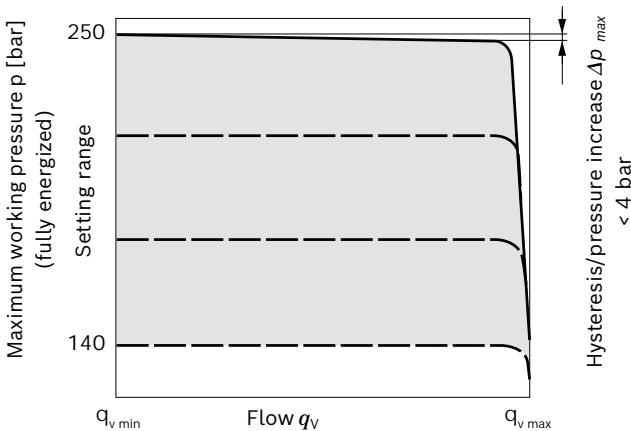

- ▶ Characteristic curves valid for  $n_1 = 1500$  rpm and  $\vartheta_{\text{fluid}} = 50$  °C.
- ▶ Pilot fluid consumption: 3 to 4.5 l/min.
- ▶ Standby standard 14 bar. Other values on request.
- ▶ Influence of pressure setting on standby  $\pm 2$  bar.

### ▼ Circuit diagram ER71/ER72

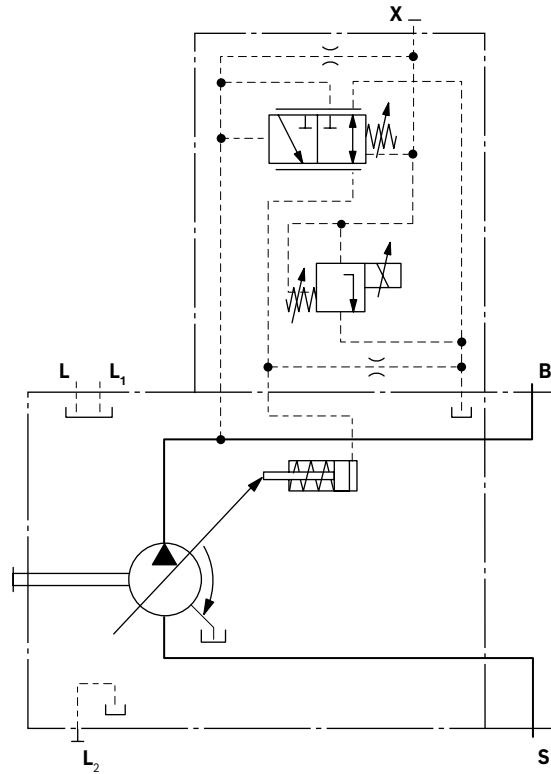

Technical data, solenoids	ER71	ER72
Voltage	12 V ( $\pm 20\%$ )	24 V ( $\pm 20\%$ )
Control current		
Start of control at $p_{\min}$	100 mA	50 mA
End of control at $p_{\max}$	1200 mA	600 mA
Current limit	1.54 A	0.77 A
Nominal resistance (at 20 °C)	5.5 $\Omega$	22.7 $\Omega$
Dither frequency	100 Hz	100 Hz
Recommended amplitude Peak to peak <sup>1)</sup>	240 mA	120 mA
Duty cycle	100%	100%
Type of protection: see connector version page 68		
Operating temperature range at valve	-20 °C to +115 °C	

### Project planning note!

Excessive current levels ( $I > 1200$  mA at 12 V or  $I > 600$  mA at 24 V) to the ER solenoid can result in undesired pressure increases which can lead to pump or system damage. Therefore:

- ▶ Use  $I_{\max}$  current limiter solenoids.
- ▶ An intermediate plate pressure controller can be used to protect the pump in the event of overflow.

An accessory kit with intermediate plate pressure controller can be ordered from Bosch Rexroth under part number R902490825.

<sup>1)</sup>  $\Delta I = 44\%$  of the current difference within the control range, regardless of the mean value of the current

## EP – Electro-proportional control

Electro proportional control makes a continuous and reproducible setting of the pump displacement possible directly via the cradle. The control force of the control piston is applied by a proportional solenoid. The control is proportional to the current (for start of control, see table right).

In a depressurized state, the pump is swiveled to its initial position ( $V_{g \max}$ ) by an adjusting spring. If the working pressure exceeds a limit value of approx. 4 bar, the pump starts to swivel from  $V_{g \max}$  to  $V_{g \min}$  without control by the solenoid (control current < start of control). With a minimum swivel angle  $V_{g \min}$  and de-energized EP solenoids, a minimum pressure of 10 bar must be maintained. A PWM signal is used to control the solenoid.

**EP.D:** The pressure control regulates the pump displacement back to  $V_{g \min}$  after the pressure command value has been reached.

A minimum operating pressure of 14 bar is needed for safe and reproducible control. The required control fluid is taken from the high pressure.

### ▼ Characteristic curve EP1/2

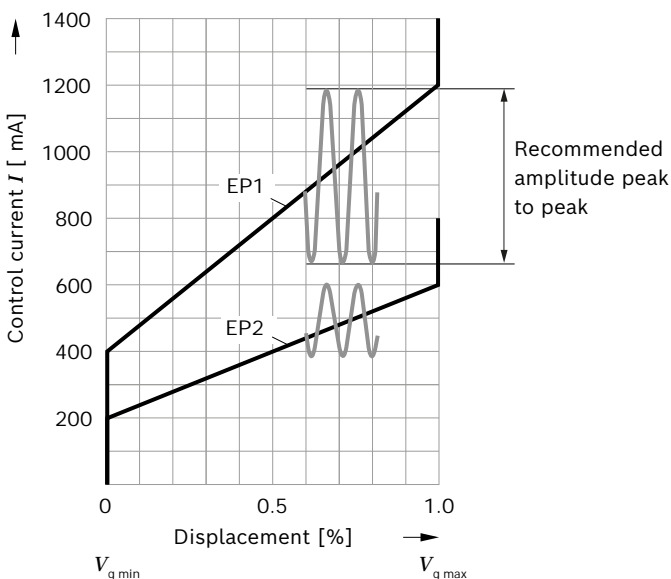

- Hysteresis static current-displacement characteristic curve < 5 %.

### ▼ Circuit diagram EP.D

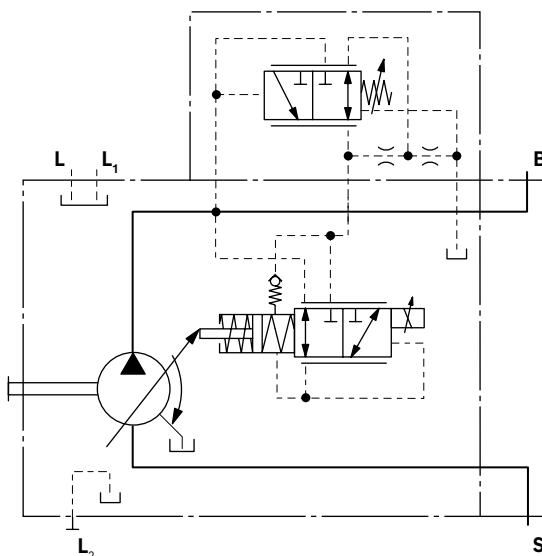

Technical data, solenoids	EP1	EP2
Voltage	12 V ( $\pm 20\%$ )	24 V ( $\pm 20\%$ )
Control current		
Start of control at $V_{g \min}$	400 mA	200 mA
End of control at $V_{g \max}$	1200 mA	600 mA
Dither frequency	100 Hz	100 Hz
Recommended amplitude Peak to peak <sup>1)</sup>	240 mA	120 mA
Current limit	1.54 A	0.77 A
Nominal resistance (at 20 °C)	5.5 $\Omega$	22.7 $\Omega$
Duty cycle	100%	100%
Type of protection: see connector version page 68		
Operating temperature range at valve -20 °C to +115 °C		

### Notice!

We recommend the valve with flushing function for the EP.D control variant. Please contact us.

<sup>1)</sup>  $\Delta I = 44\%$  of the current difference within the control range, regardless of the mean value of the current

## EK – Electro-proportional control with controller cut-off

Variant EK... is based completely on the variant EP... (see page 21).

In addition to the electro-proportional control function, a controller cut-off is integrated in the electric characteristic curve. The pump then swivels to  $V_{g \max}$  if the pilot signal is lost (e.g. cable break) and then works with the DRF settings if necessary (see page 12). The controller cut-off is only intended for short-term use and not for permanent use if the control signal is lost. If the control signal is lost, the pump swivel times are increased by the EK valve.

A PWM signal is used to control the solenoid.

### Notice!

A minimum operating pressure of 50 bar is needed for safe and reproducible electro-proportional control with controller cut-off. For lower pressures, a pilot signal of > 500 mA (EK2) or > 1000 mA (EK1) is required in order to avoid undesired controller cut-off. The required control fluid is taken from the high pressure.

In  $V_{g \max}$  position, the spring force of the return spring is maximum. To overcome the force of this spring, the solenoid must be subjected to excessive current ( $I_{res}$ ).

### ▼ Characteristic curve EK1/2

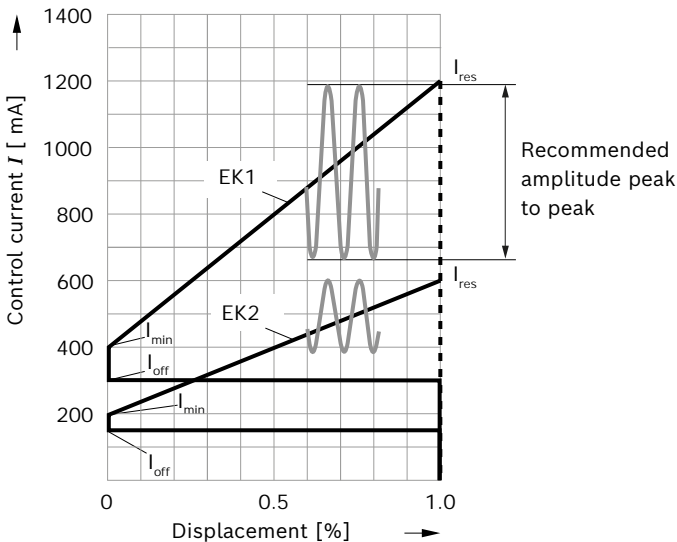

- ▶ Hysteresis static current-displacement characteristic curve < 5 %.
- ▶ For changes in current, ramp times of > 200 ms must be observed

### ▼ Circuit diagram EK.D

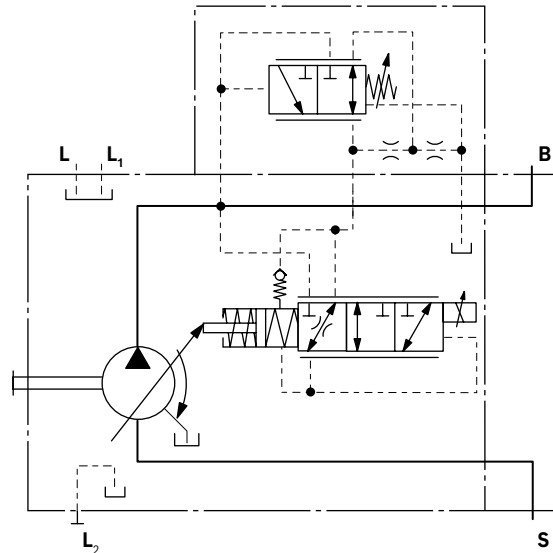

Technical data, solenoids	EK1	EK2
Voltage	12 V (±20%)	24 V (±20%)
Control current		
Start of control at $V_{g \min}$	400 mA	200 mA
End of control at $V_{g \max}$	1200 mA	600 mA
Dither frequency	100 Hz	100 Hz
Recommended amplitude Peak to peak <sup>1)</sup>	240 mA	120 mA
Current limit	1.54 A	0.77 A
Nominal resistance (at 20 °C)	5.5 Ω	22.7 Ω
Duty cycle	100%	100%
Type of protection: see connector version page 68		
Operating temperature range at valve	-20 °C to +115 °C	

	EK1	EK2
$I_{\min}$ [mA]	400	200
$I_{\max}$ [mA]	1200	600
$I_{\text{off}}$ [mA]	< 300	< 150
$I_{\text{res}}$ [mA]	> 1200	> 600

### Notice!

We recommend the valve with flushing function for the EK.D control variant. Please contact us.

1)  $\Delta I$  = 44% of the current difference within the control range, regardless of the mean value of the current

## EP(K).DF / EP(K).DS / EP(K) – with pressure flow controller

A hydraulic pressure flow control is superimposed on the electro-proportional control.

The pressure control regulates the pump displacement infinitely varied back to  $V_{g\ min}$  after the set pressure command value has been reached.

This function is super-imposed on the EP or EK control, i.e. the control-current dependent EP or EK function is executed below the pressure command value.

For the setting range of the pressure flow controller, see page 12 to 15.

With all controller combinations, the  $V_g$  reduction has priority.

With flow control, the pump flow can be influenced in addition to pressure control. The pump flow is thus equal to the actual amount of hydraulic fluid required by the consumer. This is achieved using the differential pressure at the consumer (e.g. orifice).

The EP.DS or EK.DS version has no connection between **X** and the reservoir (load-sensing). Please refer to the notes on page 14.

### ▼ Circuit diagram EP.D

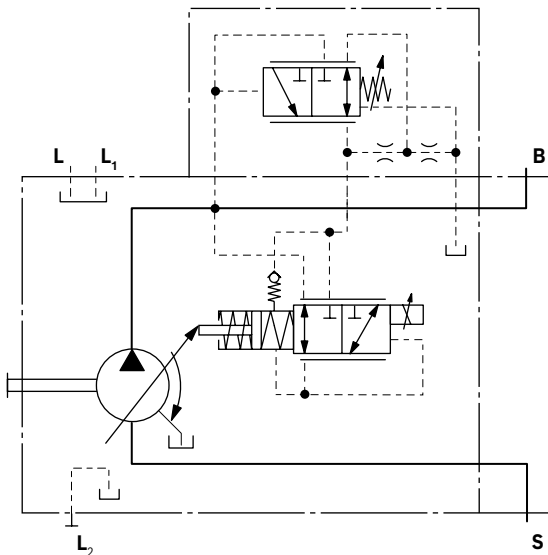

1 The metering orifice (control block) and the line are not included in the scope of delivery.

### ▼ Circuit diagram EP.DF

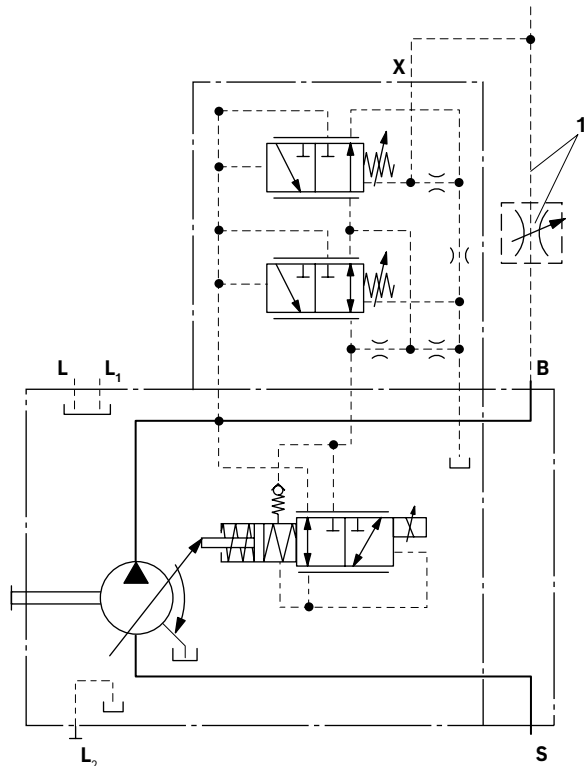

### ▼ Circuit diagram EP.DS

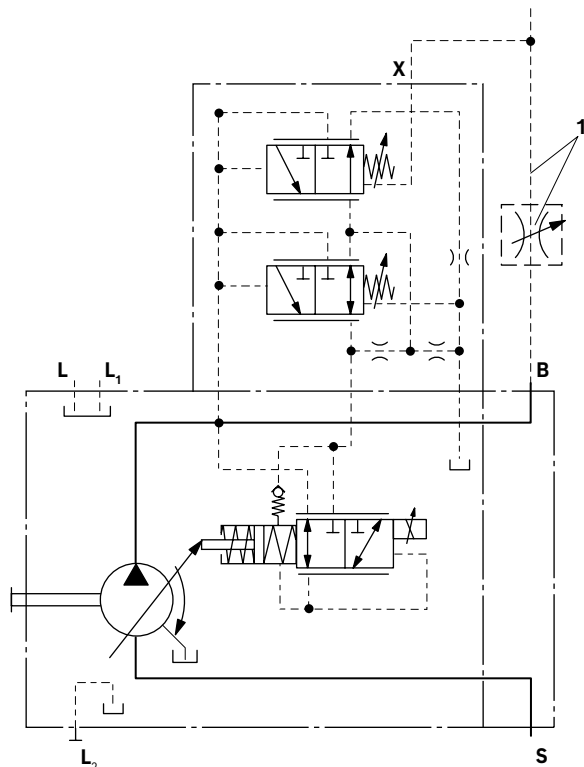

## EP.ED / EK.ED – with electro-hydraulic pressure control

The ED valve is set to a certain pressure by a specified variable solenoid current.

When changing the consumer (load pressure), this causes an increase or decrease in the pump swivel angle (flow) in order to maintain the electrically set pressure level.

The pump thus only delivers as much hydraulic fluid as the consumers can take. The pressure can be set steplessly by the solenoid current.

As the solenoid current signal drops towards zero, the pressure will be limited to  $p_{max}$  by an adjustable hydraulic pressure cut-off (negative characteristic curve, e.g. for fan speed control). A PWM signal is used to control the solenoid.

For further information and technical data of the solenoids for ED(ER) control please refer to pages 18 to 22.

### ▼ Circuit diagram EP.ED

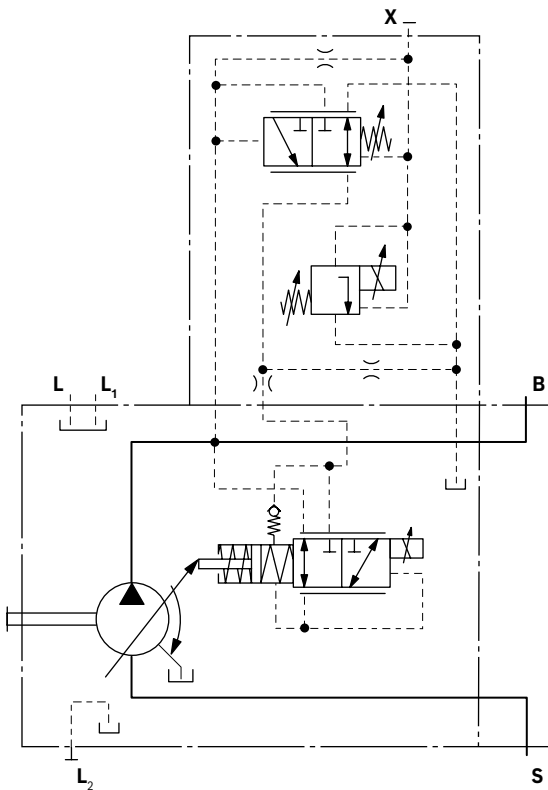

### ▼ Circuit diagram EK.ED

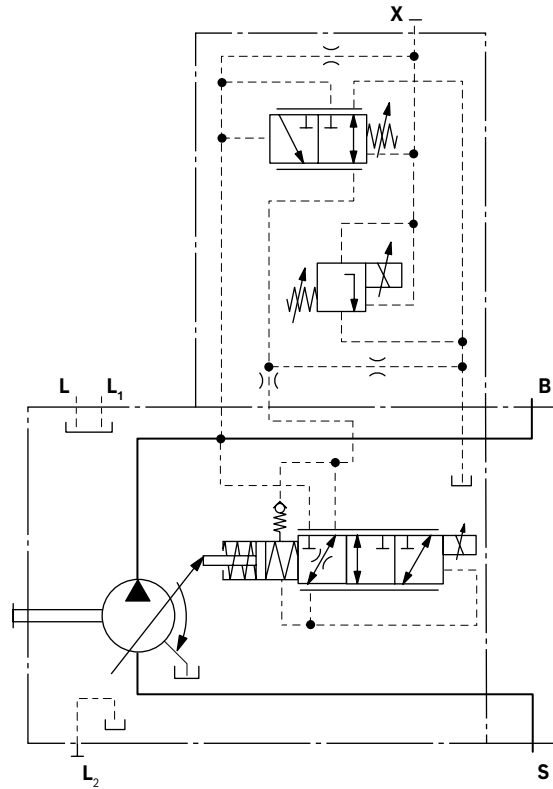



## Dimensions, size 10

### DR - Pressure controller; mounting flange A metric; series 52

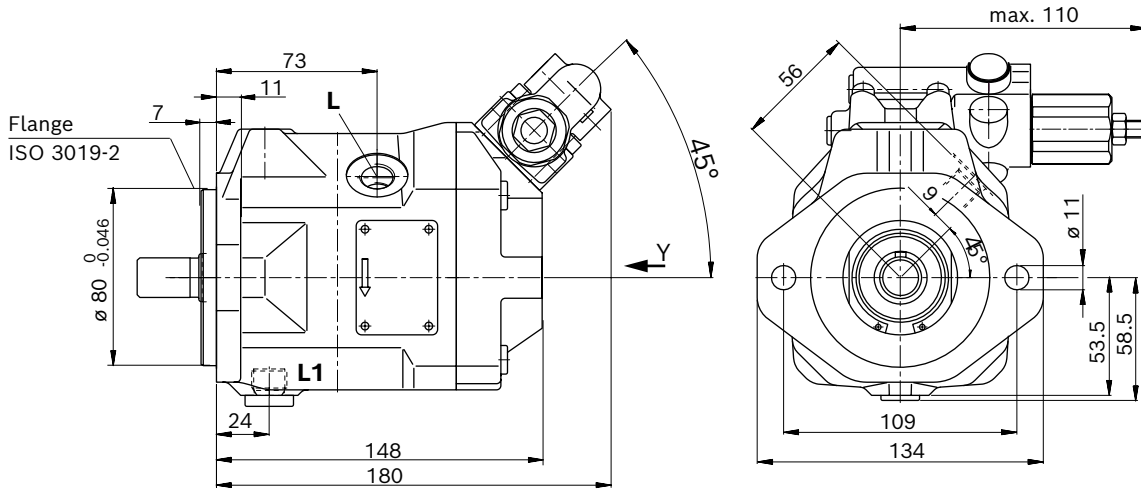

▼ **View Y**  
 Valve mounting  
 for clockwise  
 rotation

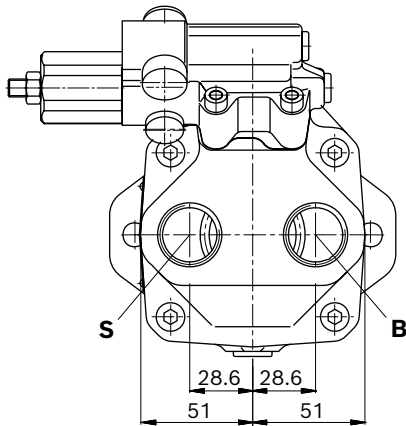

▼ **View Y**  
 Valve mounting for  
 counter-clockwise  
 rotation

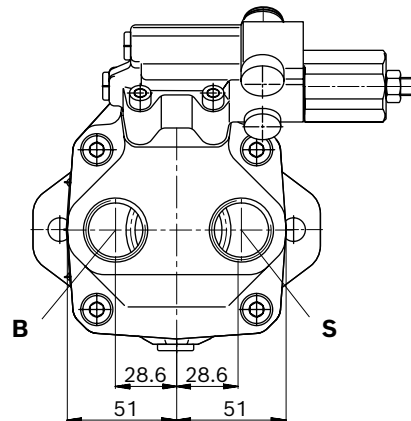

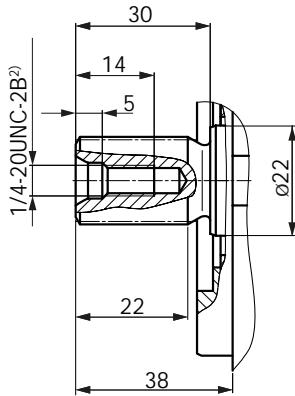
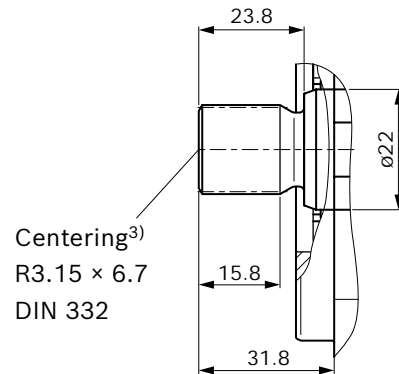
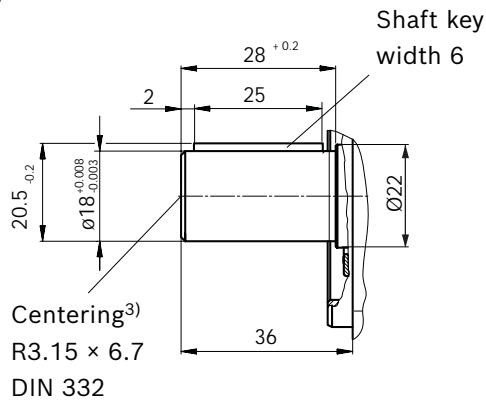
**▼ Splined shaft 3/4 in (19-4, ISO 3019-1)**
**S – 11T 16/32DP<sup>1)</sup>**

**▼ Splined shaft 5/8 in (16-4, ISO 3019-1)**
**U – 9T 16/32DP<sup>1)</sup>**

**▼ Parallel keyed shaft DIN 6885**
**P – A6x6x25**

Ports	Standard	Size	$p_{max}$ [bar] <sup>4)</sup>	State <sup>7)</sup>	
<b>B</b>	Working port	DIN 3852	M27 × 2; 16 deep	315	O
<b>S</b>	Suction port	DIN 3852	M27 × 2; 16 deep	5	O
<b>Ports at mounting flange A metric</b>					
<b>L</b>	Drain port	DIN 3852 <sup>5)</sup>	M16 × 1.5; 12 deep	2	O <sup>6)</sup>
<b>L<sub>1</sub></b>	Drain port	DIN 3852 <sup>5)</sup>	M16 × 1.5; 12 deep	2	X <sup>6)</sup>
<b>X with adapter</b>	Pilot pressure	DIN 3852	M14 × 1.5; 12 deep	315	O
<b>Ports at mounting flange C SAE</b>					
<b>L</b>	Drain port	ISO 11926 <sup>5)</sup>	9/16-18UNF-2B; 12 deep	2	O <sup>6)</sup>
<b>L<sub>1</sub> with adapter</b>	Drain port	ISO 3852 <sup>5)</sup>	M16 × 1.5; 12 deep	2	X <sup>6)</sup>
<b>X with adapter</b>	Pilot pressure	ISO 3852	M14 × 1.5; 12 deep	315	O

1) Involute spline according to ANSI B92.1a, 30° pressure angle, flat root, side fit, tolerance class 5  
 2) Thread according to ASME B1.1  
 3) Coupling axially secured, e.g. with a clamp coupling or radially mounted clamping screw.  
 4) Depending on the application, momentary pressure peaks can occur.  
 Keep this in mind when selecting measuring devices and fittings.

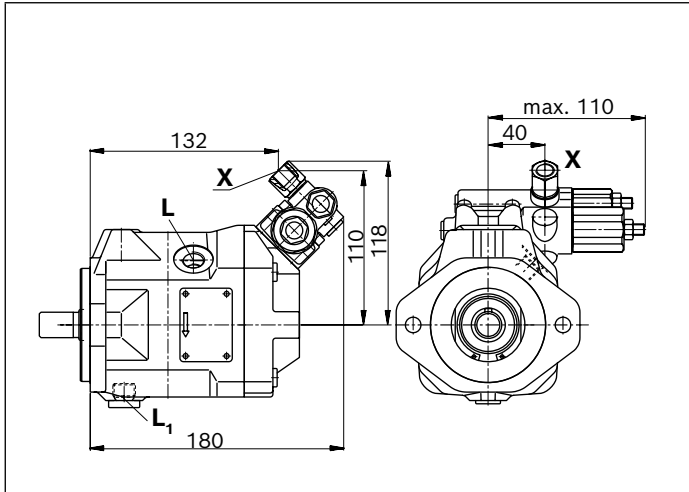
5) The countersink may be deeper than specified in the standard.  
 6) Depending on the installation position, **L** or **L<sub>1</sub>** must be connected (also see installation instructions starting on page 69).  
 7) O = Must be connected (plugged on delivery)  
 X = Plugged (in normal operation)

▼ **DRG – Pressure controller, remotely controlled (metric)**<sup>1)</sup>



▼ **DFR/DFR1 – Pressure, flow controller (metric)**<sup>1)</sup>

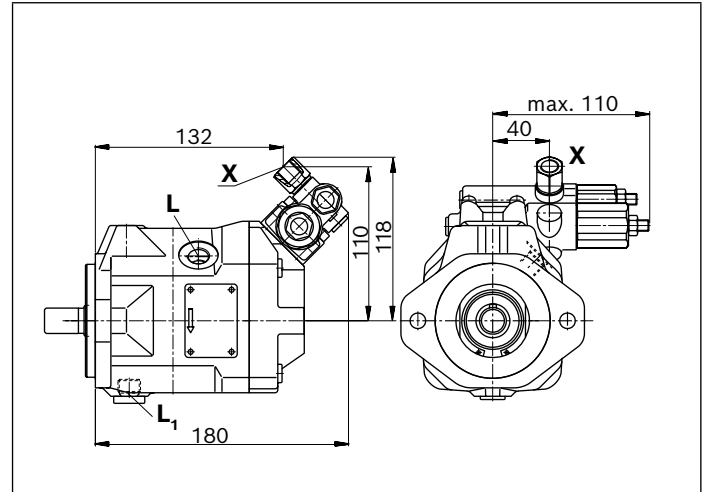

▼ **DRG – Pressure controller, remotely controlled (SAE)**<sup>1)</sup>

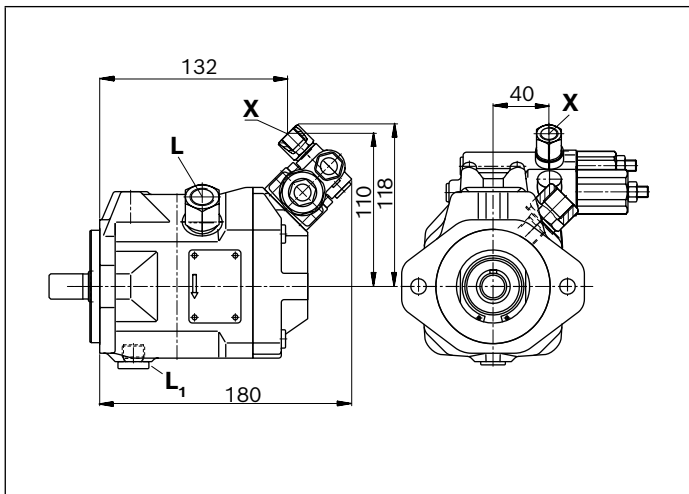

▼ **DFR/DFR1 – Pressure, flow controller (SAE)**<sup>1)</sup>

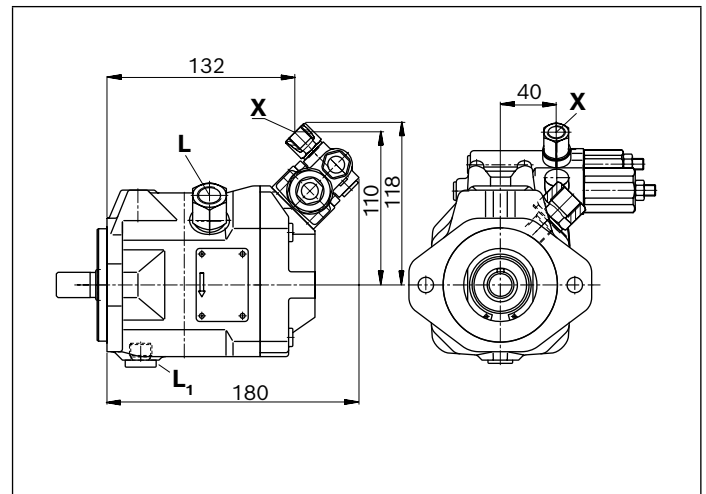

1) Valve mounting for clockwise or counter-clockwise rotation  
 see page 11 and 12

## Dimensions, size 18

### DR - Hydraulic pressure controller; Clockwise rotation, series 53

#### ▼ Port plate 11

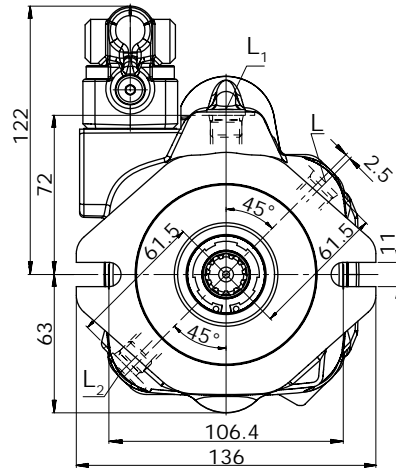
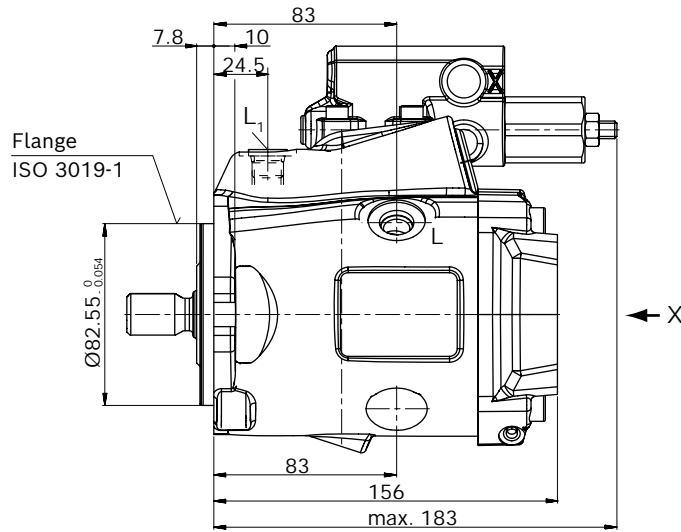

View X<sup>1</sup>)

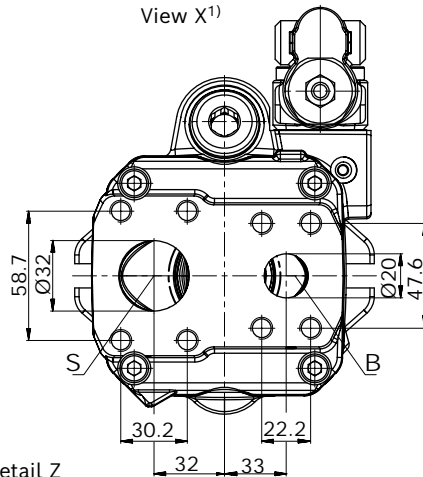

Detail Z

#### ▼ Port plate 12

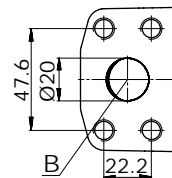
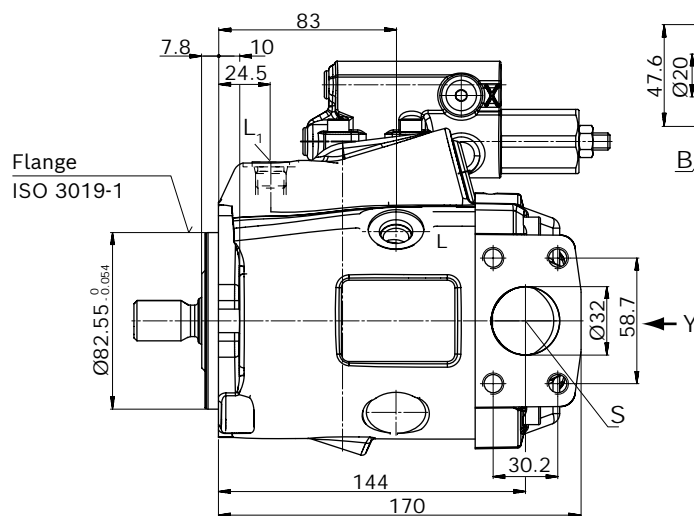

View Y<sup>1</sup>)

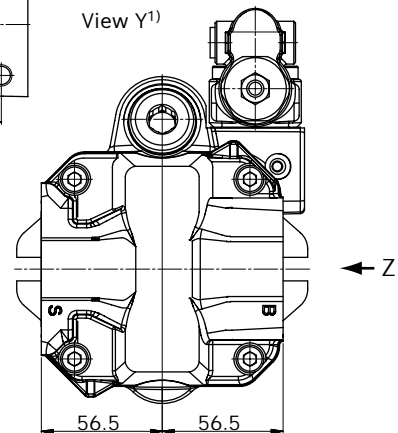

1) Dimensions of working ports turned through 180° for counter-clockwise rotation

▼ **Splined shaft 3/4 in (19-4, ISO 3019-1)**

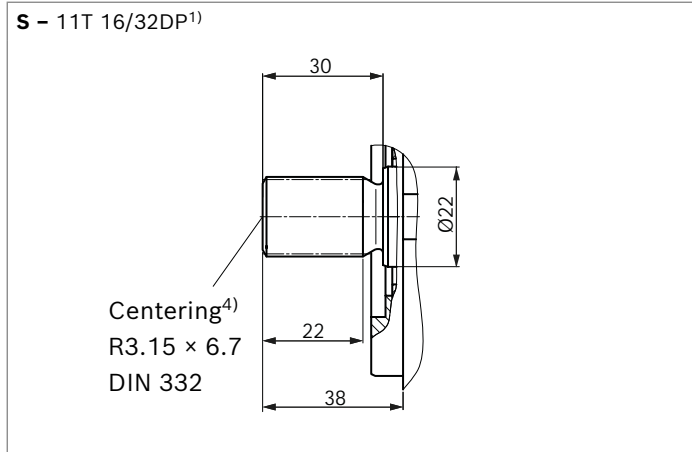

▼ **Splined shaft 3/4 in (similar to ISO 3019-1)**

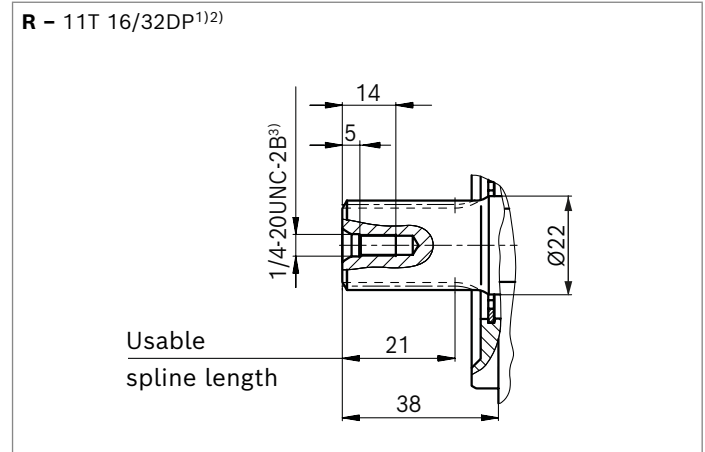

▼ **Splined shaft 5/8 in (16-4, ISO 3019-1)**

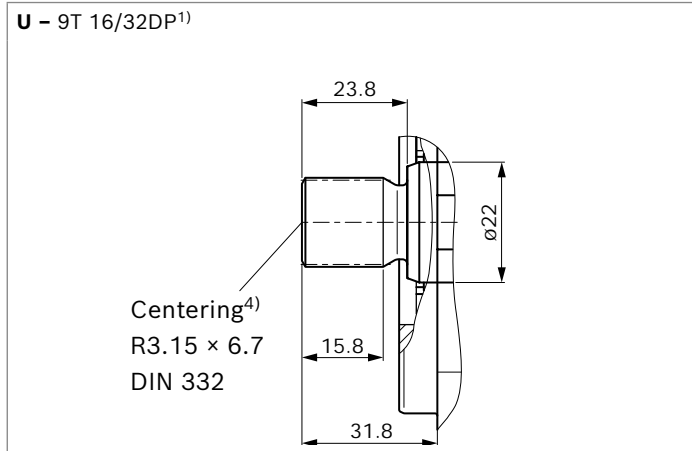

Ports	Standard	Size	$p_{max}$ [bar] <sup>5)</sup>	State <sup>8)</sup>
<b>B</b>	Working port (standard pressure series) Fastening thread	ISO 6162-1 DIN 13	3/4 in M10 × 1.5; 17 deep	315 O
<b>S</b>	Suction port (standard pressure series) Fastening thread	ISO 6162-1 DIN 13	1 1/4 in M10 × 1.5; 17 deep	5 O
<b>L</b>	Drain port	ISO 11926 <sup>6)</sup>	3/4-16UNF-2B; 12 deep	2 O <sup>7)</sup>
<b>L<sub>1</sub>, L<sub>2</sub></b>	Drain port	ISO 11926 <sup>6)</sup>	3/4-16UNF-2B; 12 deep	2 X <sup>7)</sup>
<b>X</b>	Pilot pressure	ISO 11926	7/16-20UNF-2A; 11.5 deep	315 O

1) Involute spline according to ANSI B92.1a, 30° pressure angle, flat root, side fit, tolerance class 5  
2) Splines according to ANSI B92.1a, spline runout is a deviation from standard ISO 3019-1.  
3) Thread according to ASME B1.1  
4) Coupling axially secured, e.g. with a clamp coupling or radially mounted clamping screw  
5) Depending on the application, momentary pressure peaks can occur.  
Keep this in mind when selecting measuring devices and fittings.

6) The countersink may be deeper than specified in the standard.  
7) Depending on the installation position, **L**, **L<sub>1</sub>** or **L<sub>2</sub>** must be connected (also see installation instructions starting on page 69).  
8) O = Must be connected (plugged on delivery)  
X = Plugged (in normal operation)

▼ **DRG - Pressure controller, remotely controlled, series 53**

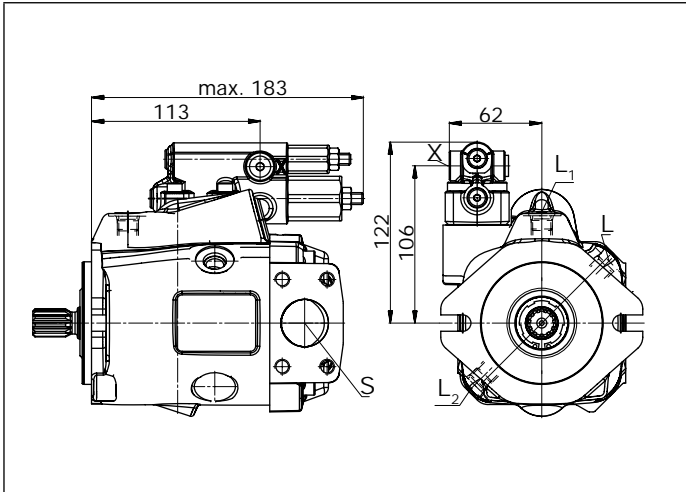

▼ **EP.D. / EK.D. - Electro-proportional control, series 53**

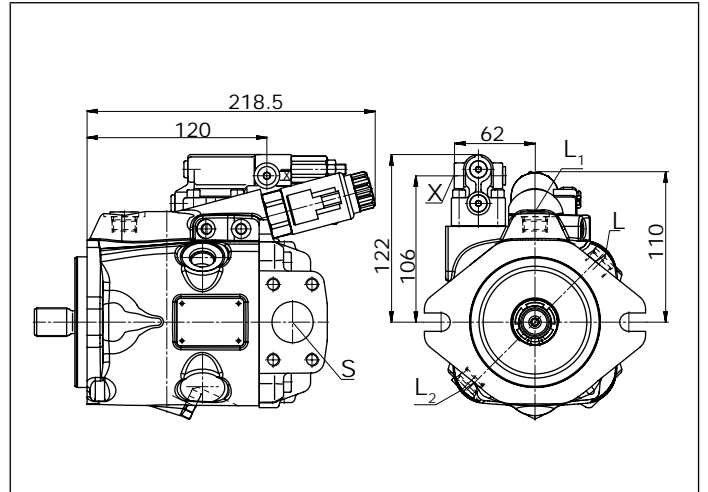

▼ **DRF/DRS/DRSC - Pressure and flow controller, series 53**

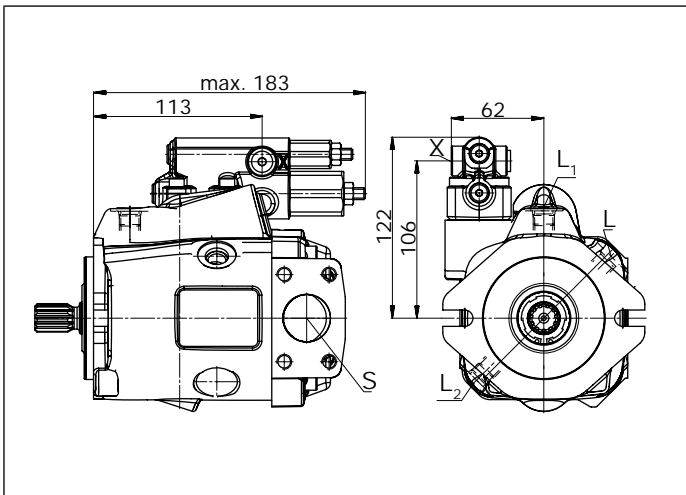

▼ **EP.ED. / EK.ED. - Electro-prop. control, series 53**

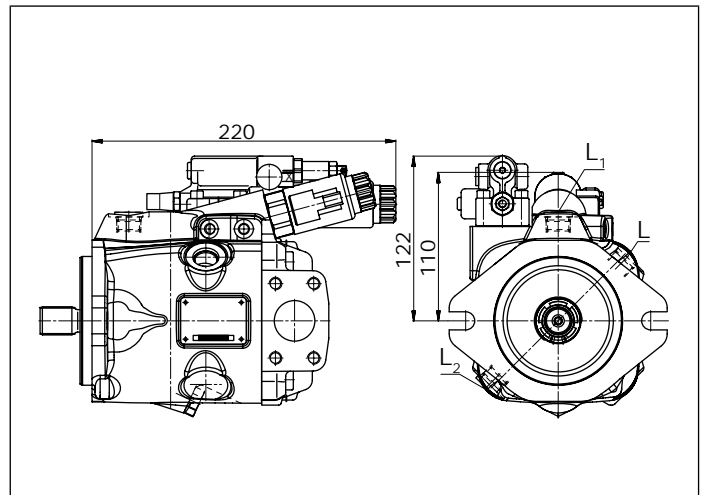

▼ **LA.D. - Pressure, flow and power controller, series 53**

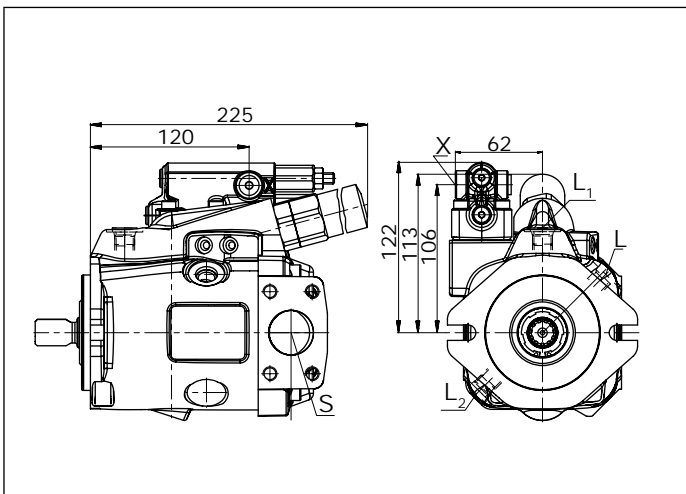

▼ **ED7. / ER7. - Electro-prop. Pressure control, series 53**

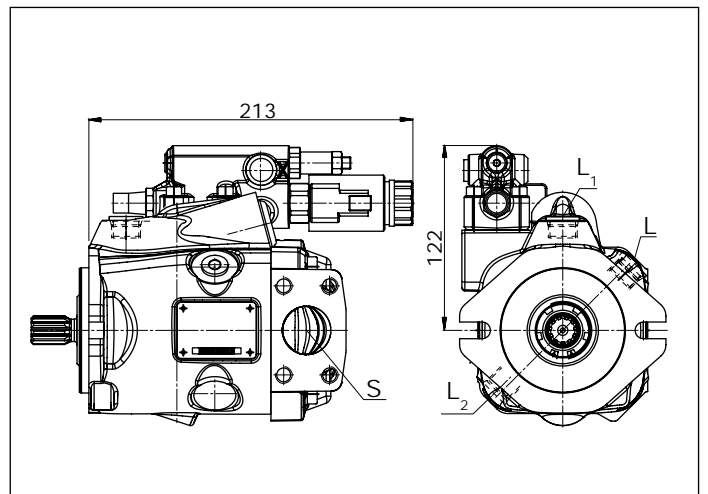

## Dimensions, size 28

### DR - Hydraulic pressure controller; Clockwise rotation, series 52

#### ▼ Port plate 11

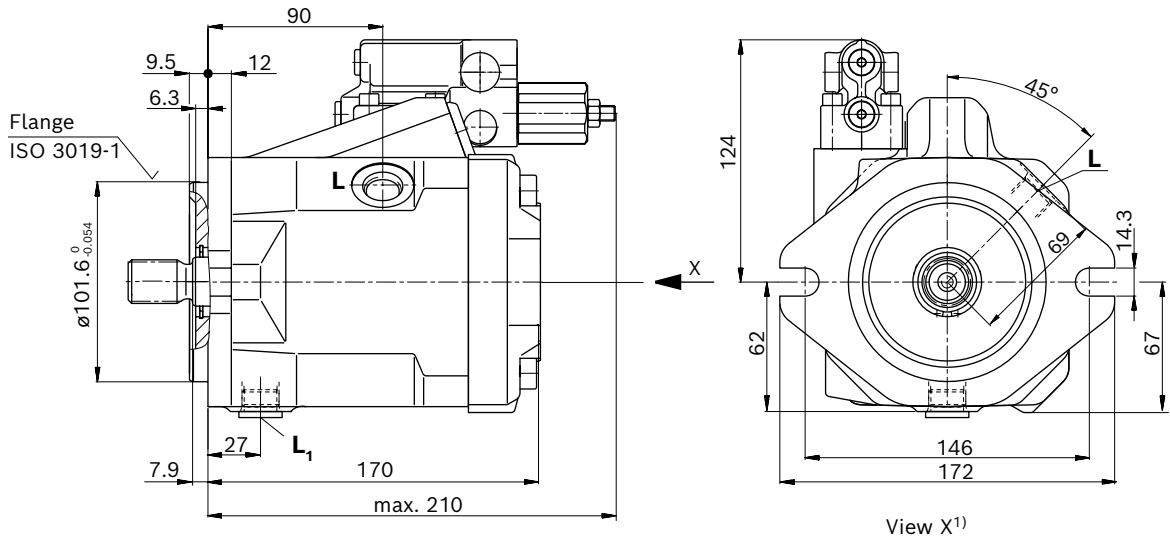

#### ▼ Port plate 12

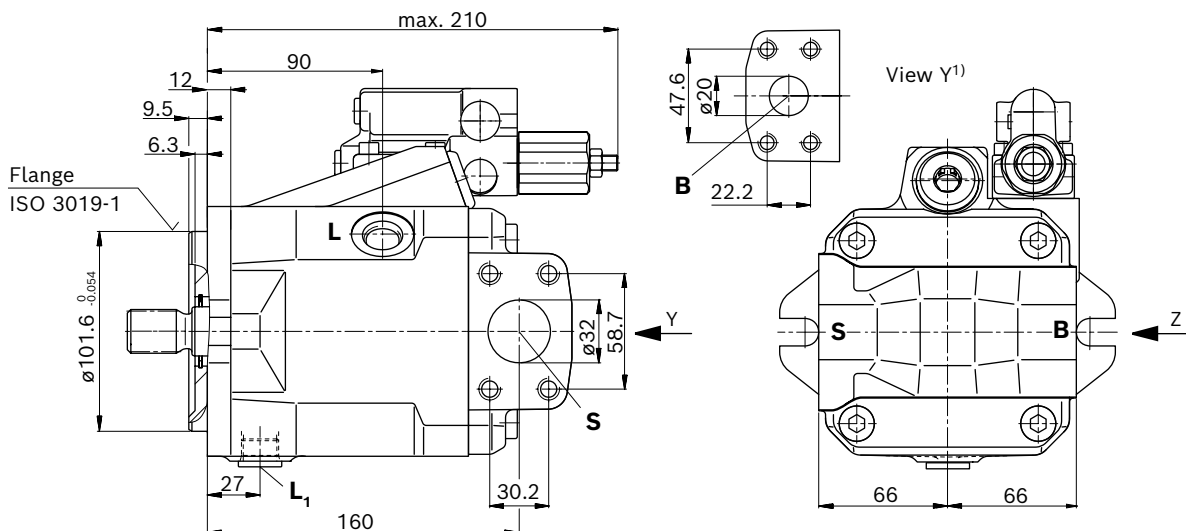

1) Dimensions of working ports turned through 180° for counter-clockwise rotation

## Dimensions, size 28

### DR – Hydraulic pressure controller; Clockwise rotation, series 53

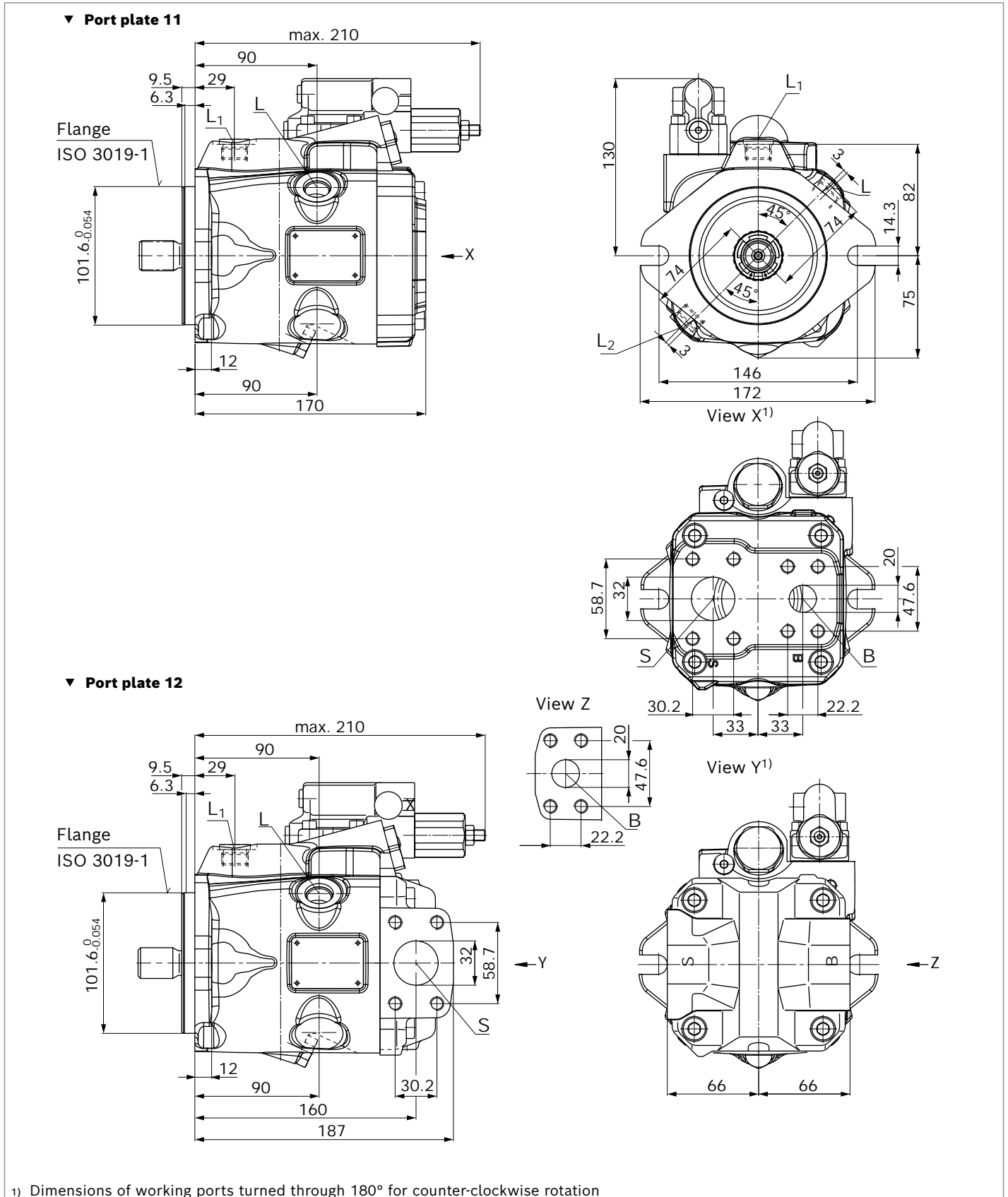

▼ **Splined shaft 7/8 in (22-4, ISO 3019-1)**

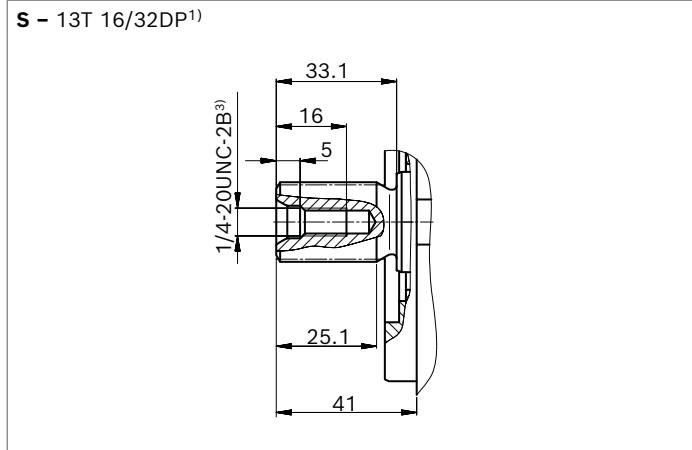

▼ **Splined shaft 7/8 in (similar to ISO 3019-1)**

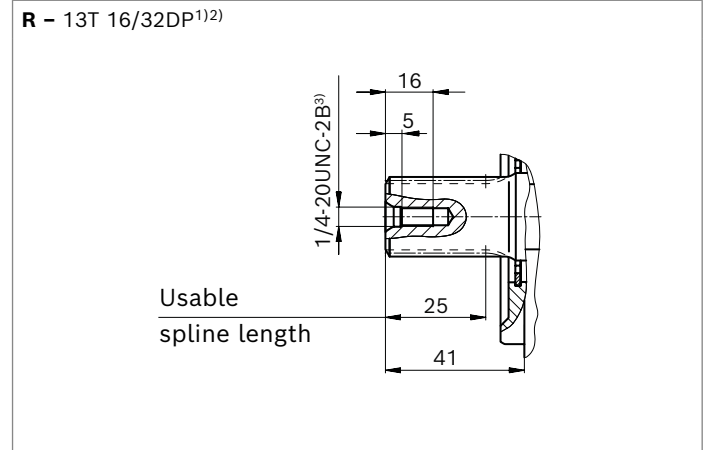

▼ **Splined shaft 3/4 in (19-4, ISO 3019-1)**

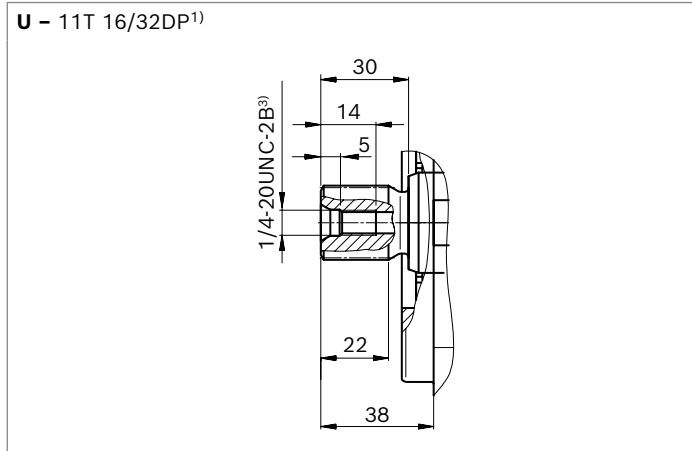

▼ **Splined shaft 3/4 in (similar to ISO 3019-1)**

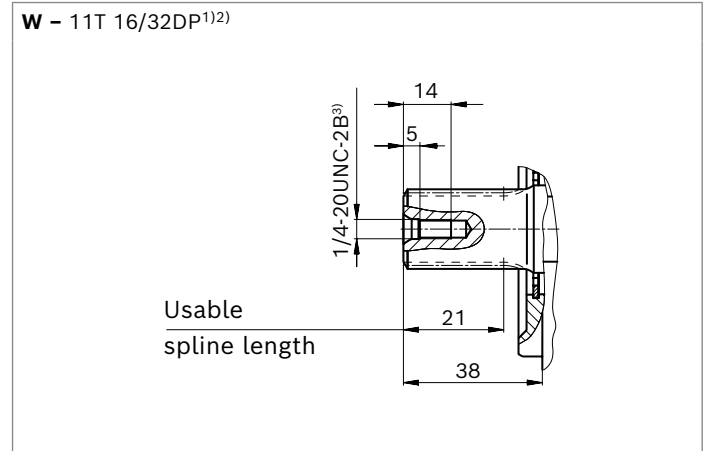

Ports	Standard	Size	$p_{max}$ [bar] <sup>4)</sup>	State <sup>8)</sup>
<b>B</b>	Working port (standard pressure series) Fastening thread	ISO 6162-1 DIN 13	3/4 in M10 × 1.5; 17 deep	315 O
<b>S</b>	Suction port (standard pressure series) Fastening thread	ISO 6162-1 DIN 13	1 1/4 in M10 × 1.5; 17 deep	5 O
<b>L</b>	Drain port	ISO 11926 <sup>5)</sup>	3/4-16UNF-2B; 12 deep	2 O <sup>6)</sup>
<b>L<sub>1</sub>, L<sub>2</sub><sup>7)</sup></b>	Drain port	ISO 11926 <sup>5)</sup>	3/4-16UNF-2B; 12 deep	2 X <sup>6)</sup>
<b>X</b>	Pilot pressure	ISO 11926	7/16-20UNF-2B; 11.5 deep	315 O

1) Involute spline according to ANSI B92.1a, 30° pressure angle, flat root, side fit, tolerance class 5  
 2) Splines according to ANSI B92.1a, spline runout is a deviation from standard ISO 3019-1.  
 3) Thread according to ASME B1.1  
 4) Depending on the application, momentary pressure peaks can occur.  
 Keep this in mind when selecting measuring devices and fittings.

5) The countersink may be deeper than specified in the standard.  
 6) Depending on the installation position, **L**, **L<sub>1</sub>** or **L<sub>2</sub>** must be connected (also see installation instructions starting on page 69).  
 7) Only for series 53  
 8) O = Must be connected (plugged on delivery)  
 X = Plugged (in normal operation)

▼ **DRG - Pressure controller, remotely controlled, series 52**

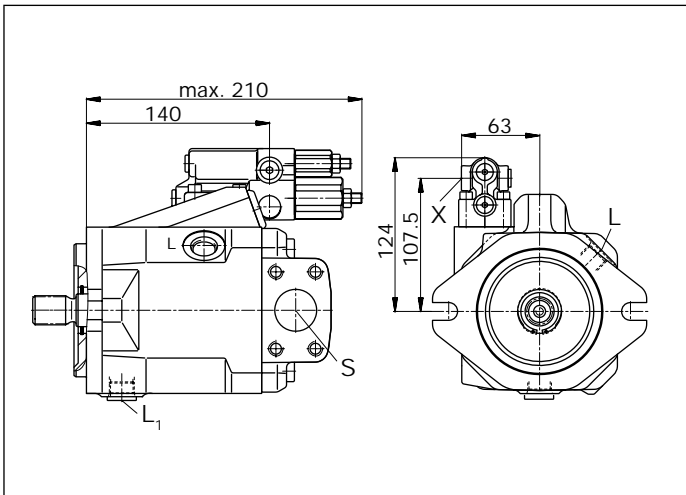

▼ **DFR/DFR1 - Pressure and flow controller, series 52**

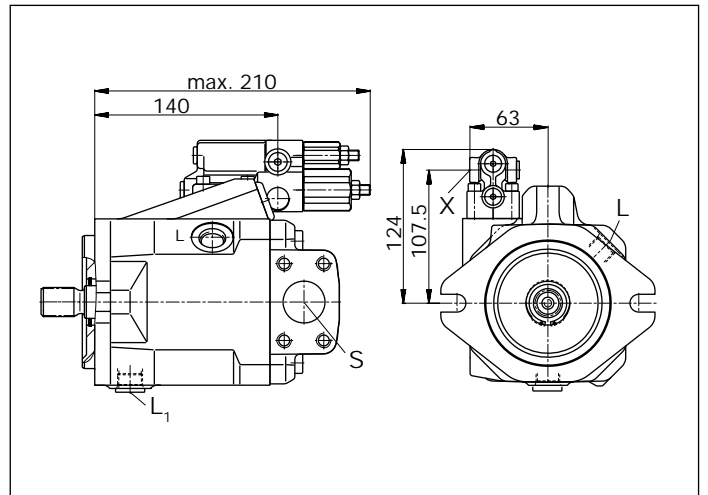

▼ **ED7. / ER7. - Electro-prop. Pressure control, series 52**

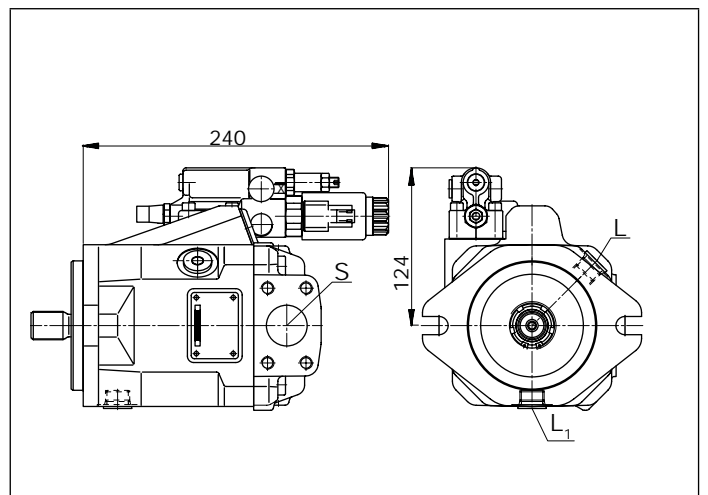

▼ **DRG – Pressure controller, remotely controlled, series 53**

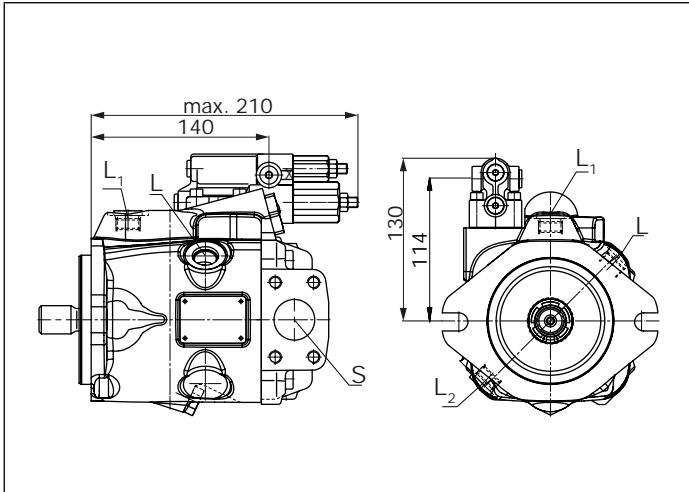

▼ **EP.D. / EK.D. – Electro-proportional control, series 53**

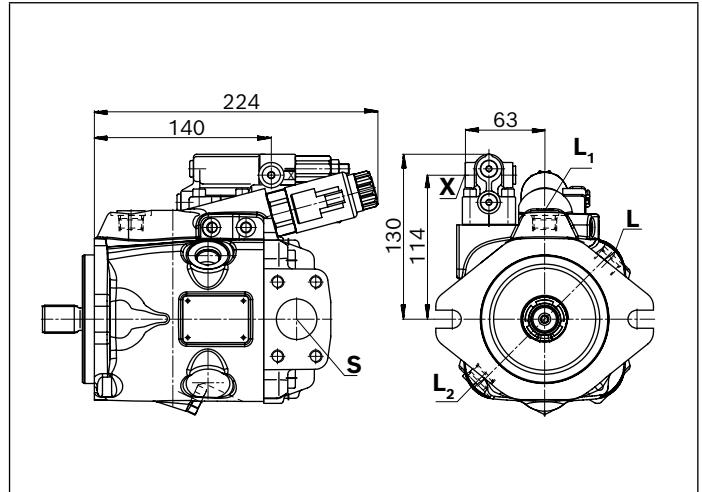

▼ **DRF/DRS/DRSC – Pressure and flow controller, Series 53**

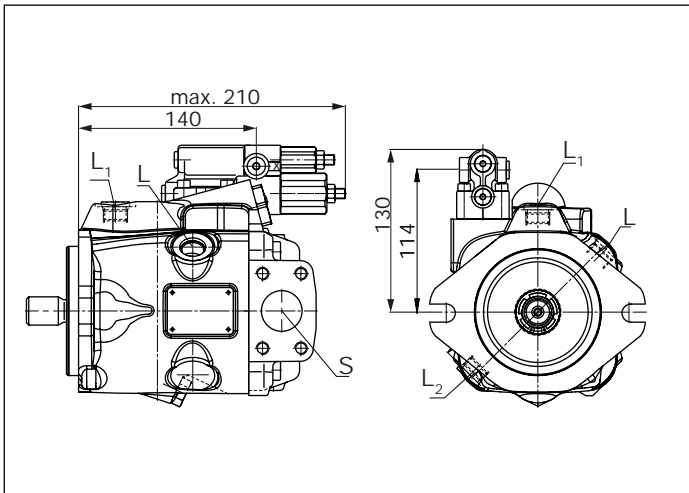

▼ **EP.ED. / EK.ED. – Electro-proportional control, Series 53**

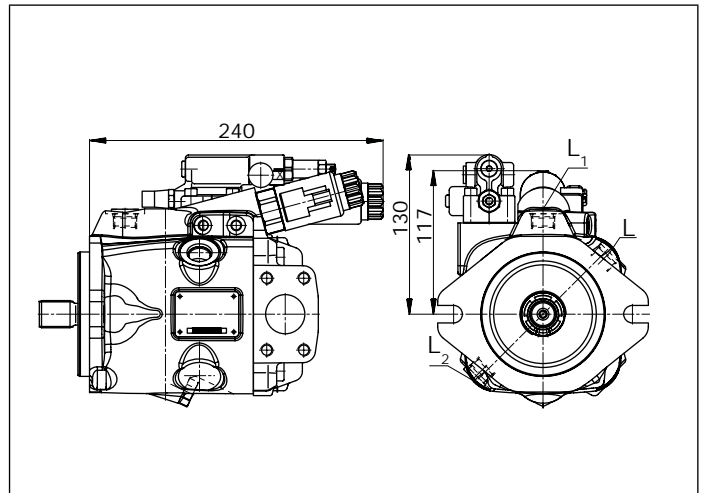

▼ **LA.D. – Pressure, flow and power controller, series 53**

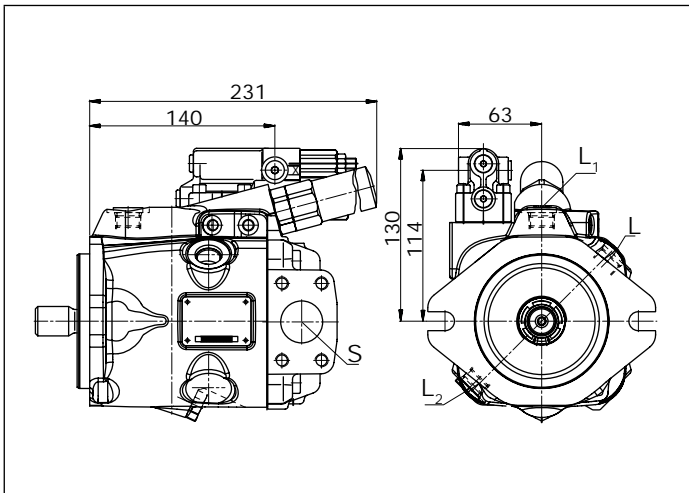

▼ **ED7. / ER7. – Electro-prop. Pressure control, series 53**

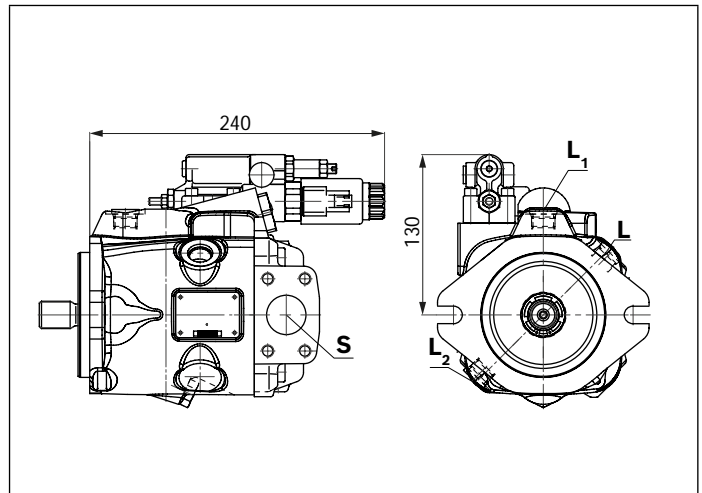

## Dimensions, size 45

### DR - Hydraulic pressure controller; Clockwise rotation, series 52

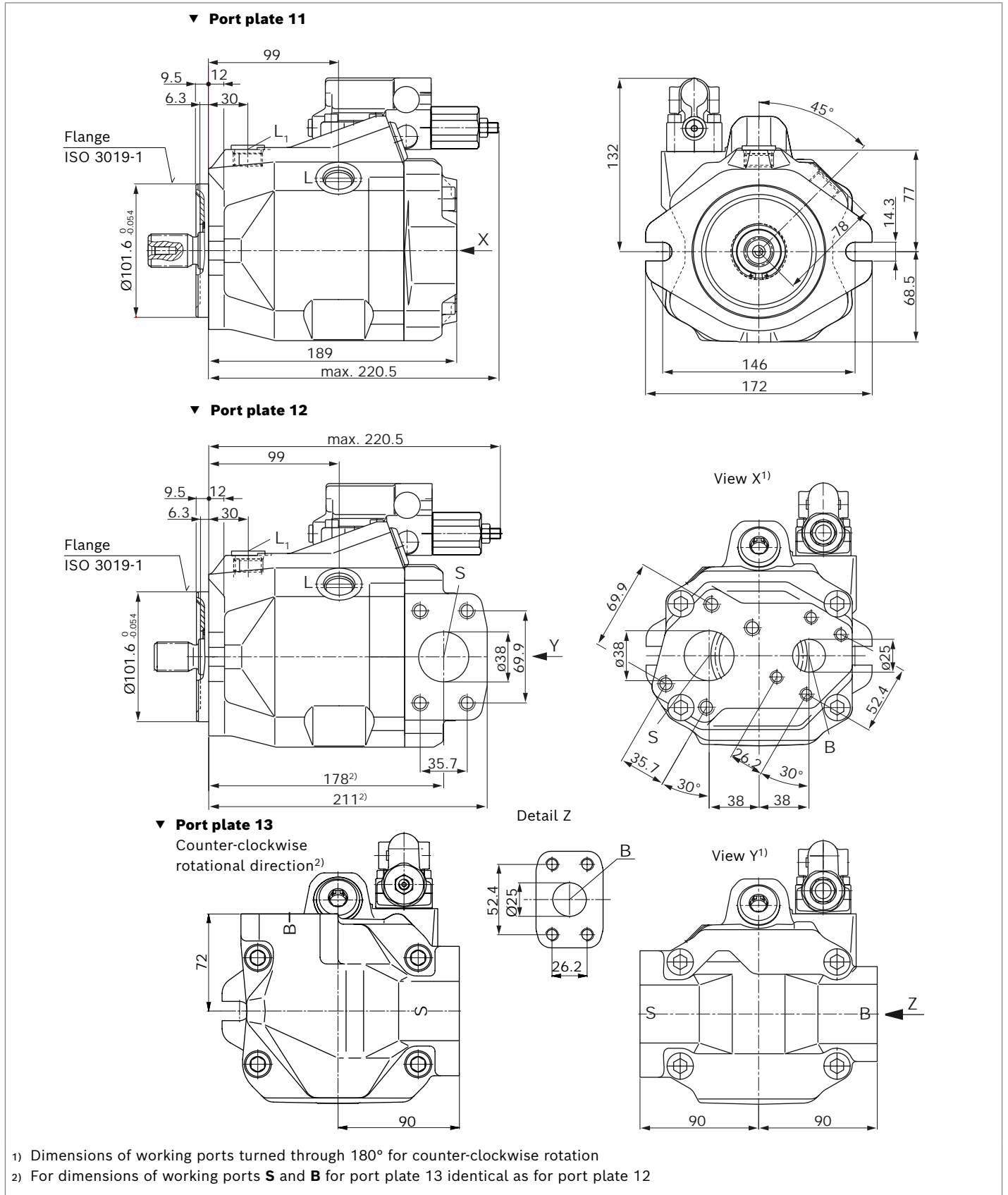

## Dimensions, size 45

### DR - Hydraulic pressure controller; Clockwise rotation, series 53

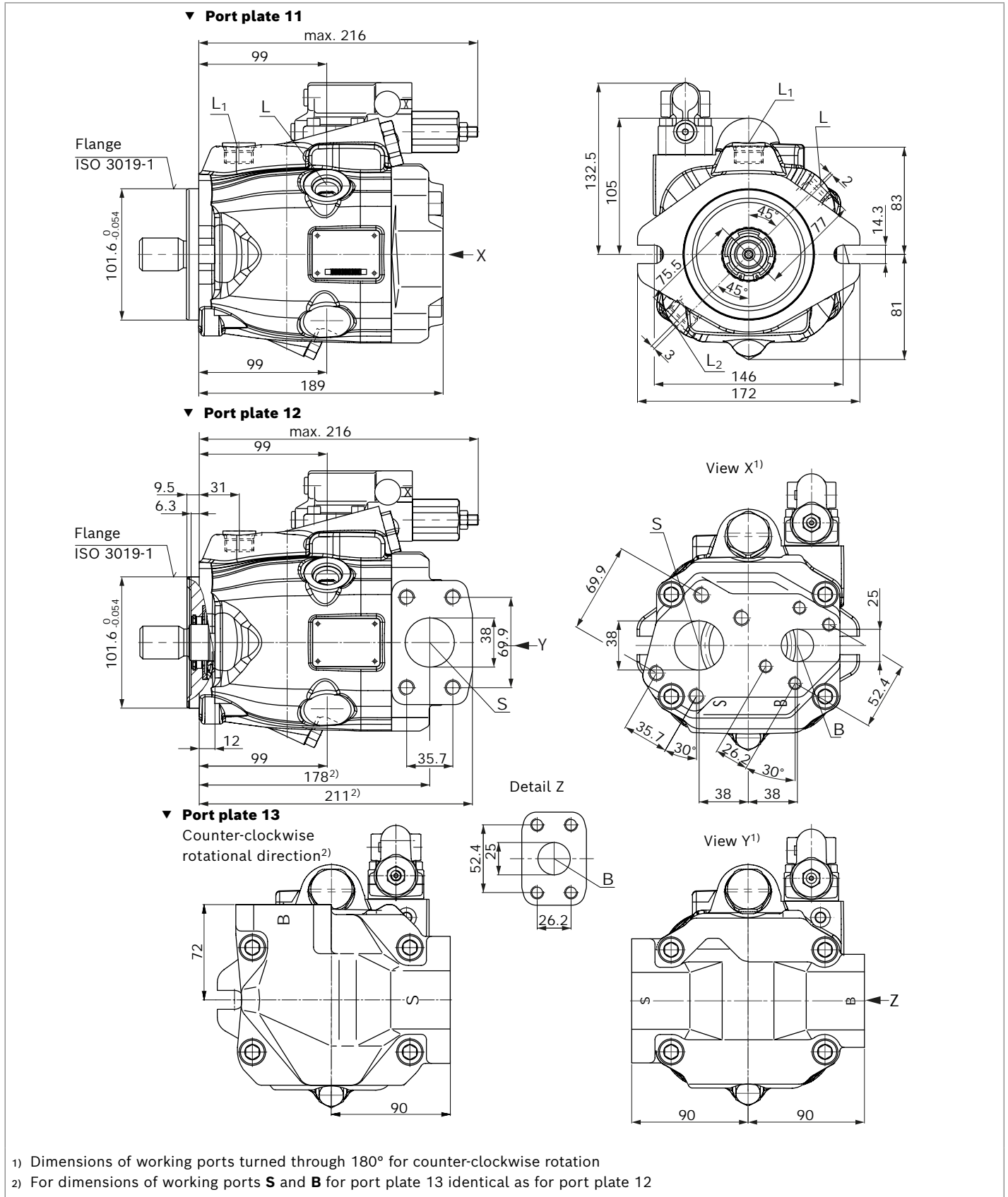

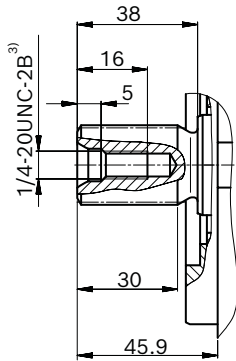
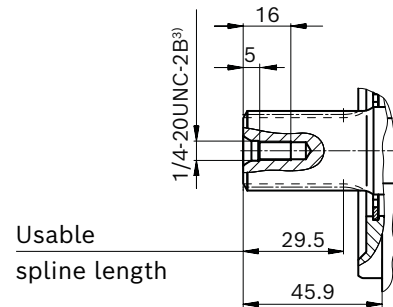
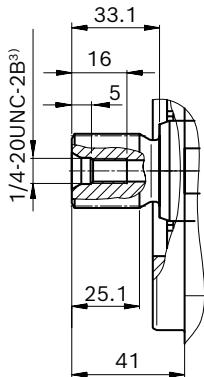
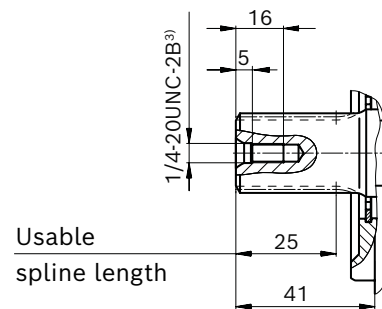
**▼ Splined shaft 1 in (25-4, ISO 3019-1)**
**S** – 15T 16/32DP<sup>1)</sup>

**▼ Splined shaft 1 in (similar to ISO 3019-1)**
**R** – 15T 16/32DP<sup>1)2)</sup>

**▼ Splined shaft 7/8 in (22-4, ISO 3019-1)**
**U** – 13T 16/32DP<sup>1)</sup>

**▼ Splined shaft 7/8 in (similar to ISO 3019-1)**
**W** – 13T 16/32DP<sup>1)2)</sup>

Ports		Standard	Size	$p_{max}$ [bar] <sup>4)</sup>	State <sup>8)</sup>
<b>B</b>	Working port (standard pressure series)	ISO 6162-1	1 in	315	O
	Fastening thread	DIN 13	M10 × 1.5; 17 deep		
<b>S</b>	Suction port (standard pressure series)	ISO 6162-1	1 1/2 in	5	O
	Fastening thread	DIN 13	M12 × 1.75; 20 deep		
<b>L</b>	Drain port	ISO 11926 <sup>5)</sup>	7/8-14UNF-2B; 13 deep	2	O <sup>6)</sup>
<b>L<sub>1</sub>, L<sub>2</sub></b> <sup>7)</sup>	Drain port	ISO 11926 <sup>5)</sup>	7/8-14UNF-2B; 13 deep	2	X <sup>6)</sup>
<b>X</b>	Pilot pressure	ISO 11926	7/16-20UNF-2A; 11.5 deep	315	O

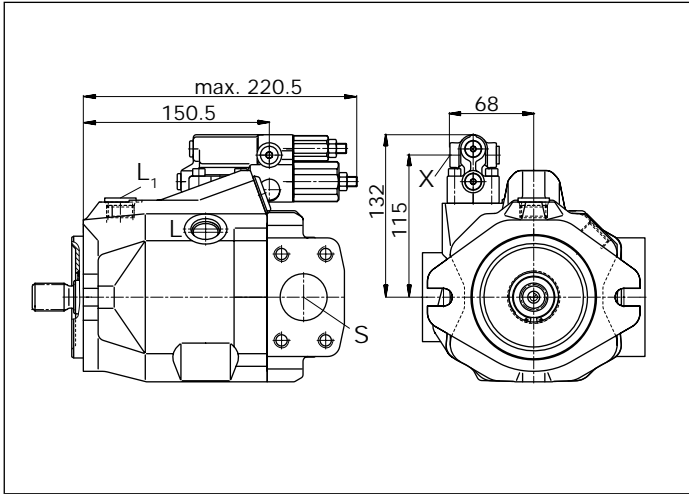
1) Involute spline according to ANSI B92.1a, 30° pressure angle, flat root, side fit, tolerance class 5  
 2) Splines according to ANSI B92.1a, spline runout is a deviation from standard ISO 3019-1.  
 3) Thread according to ASME B1.1  
 4) Depending on the application, momentary pressure peaks can occur.  
 Keep this in mind when selecting measuring devices and fittings.

5) The countersink may be deeper than specified in the standard.  
 6) Depending on the installation position, **L**, **L<sub>1</sub>** or **L<sub>2</sub>** must be connected (also see installation instructions starting on page 69).  
 7) Only series 53  
 8) O = Must be connected (plugged on delivery)  
 X = Plugged (in normal operation)

▼ **DRG – Pressure controller, remotely controlled, series 52**



▼ **DFR/DFR1/DRSC – Pressure and flow controller, series 52**

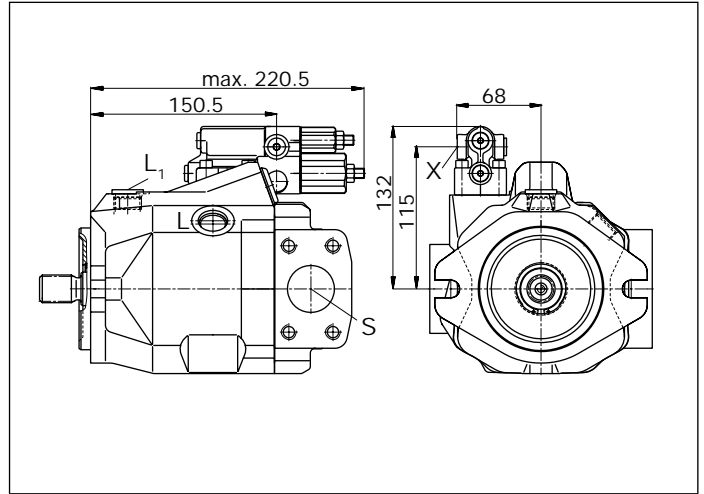

▼ **ED7. / ER7. – Electro-prop. Pressure control, series 52**

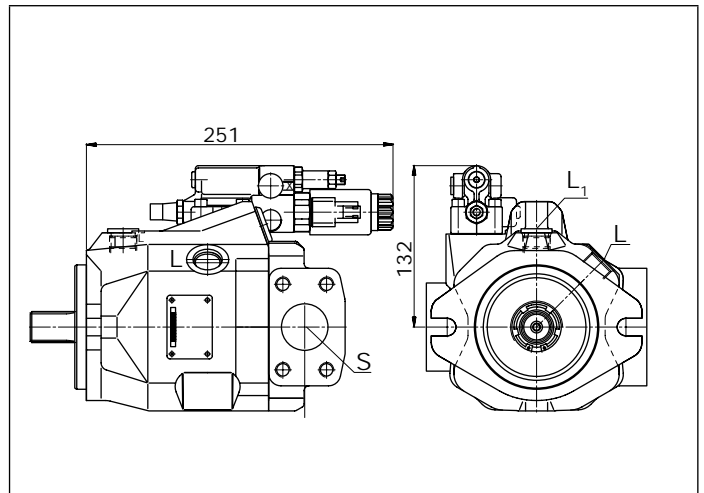

▼ **DRG - Pressure controller, remotely controlled, series 53**

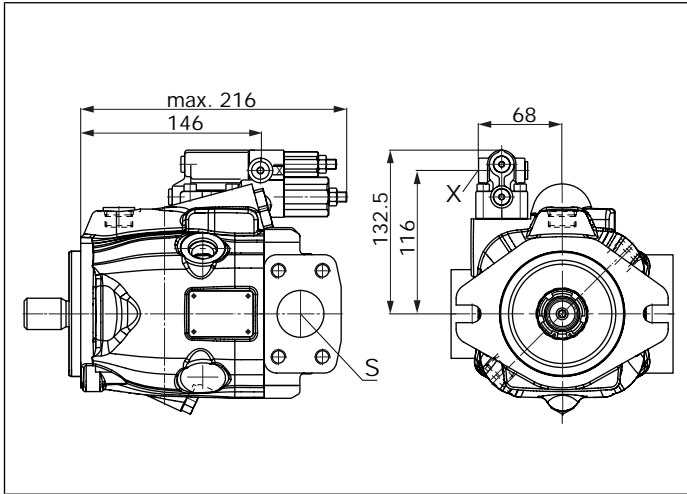

▼ **EP.D. / EK.D. - Electro-proportional control, series 53**

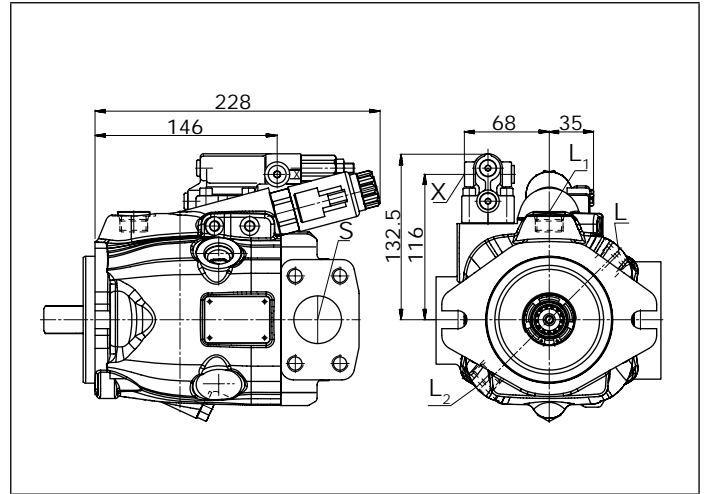

▼ **DRF/DRS/DRSC - Pressure and flow controller, Series 53**

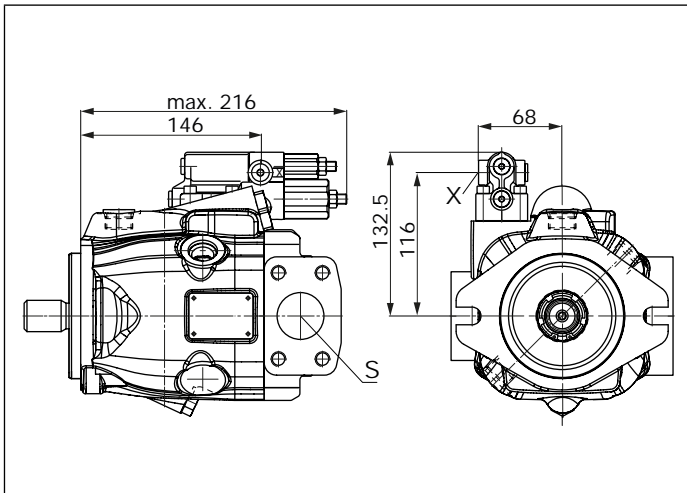

▼ **EP.ED. / EK.ED. - Electro-prop. control, series 53**

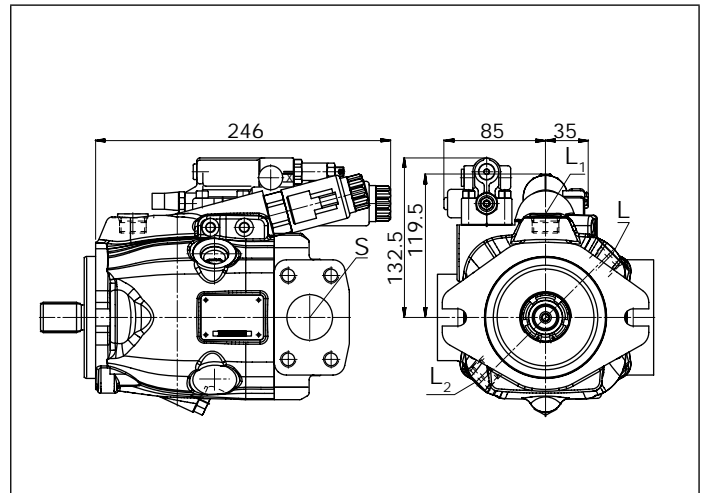

▼ **LA.D. - Pressure, flow and power controller, series 53**

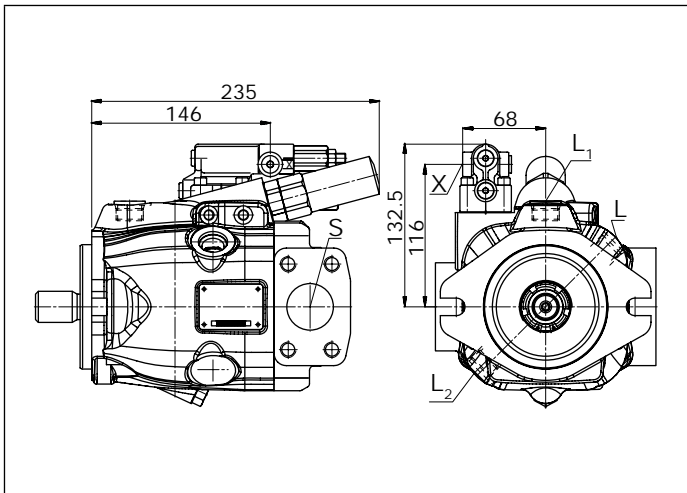

▼ **ED7. / ER7. - Electro-prop. Pressure control, series 53**

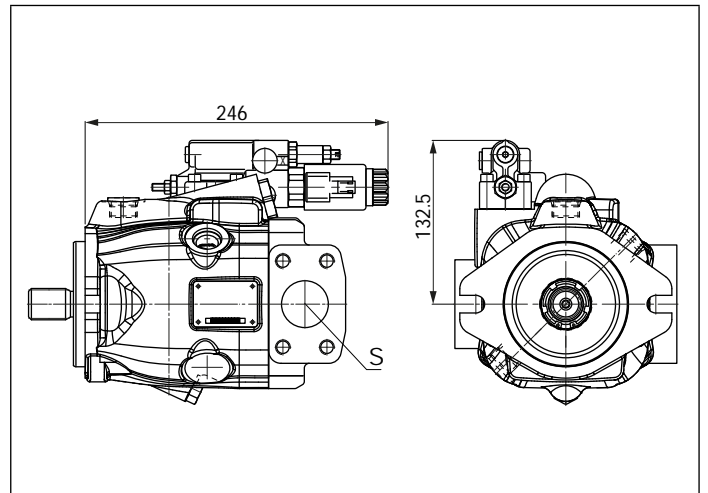

## Dimensions, size 60

### DR - Hydraulic pressure controller; Clockwise rotation, mounting flange C series 52

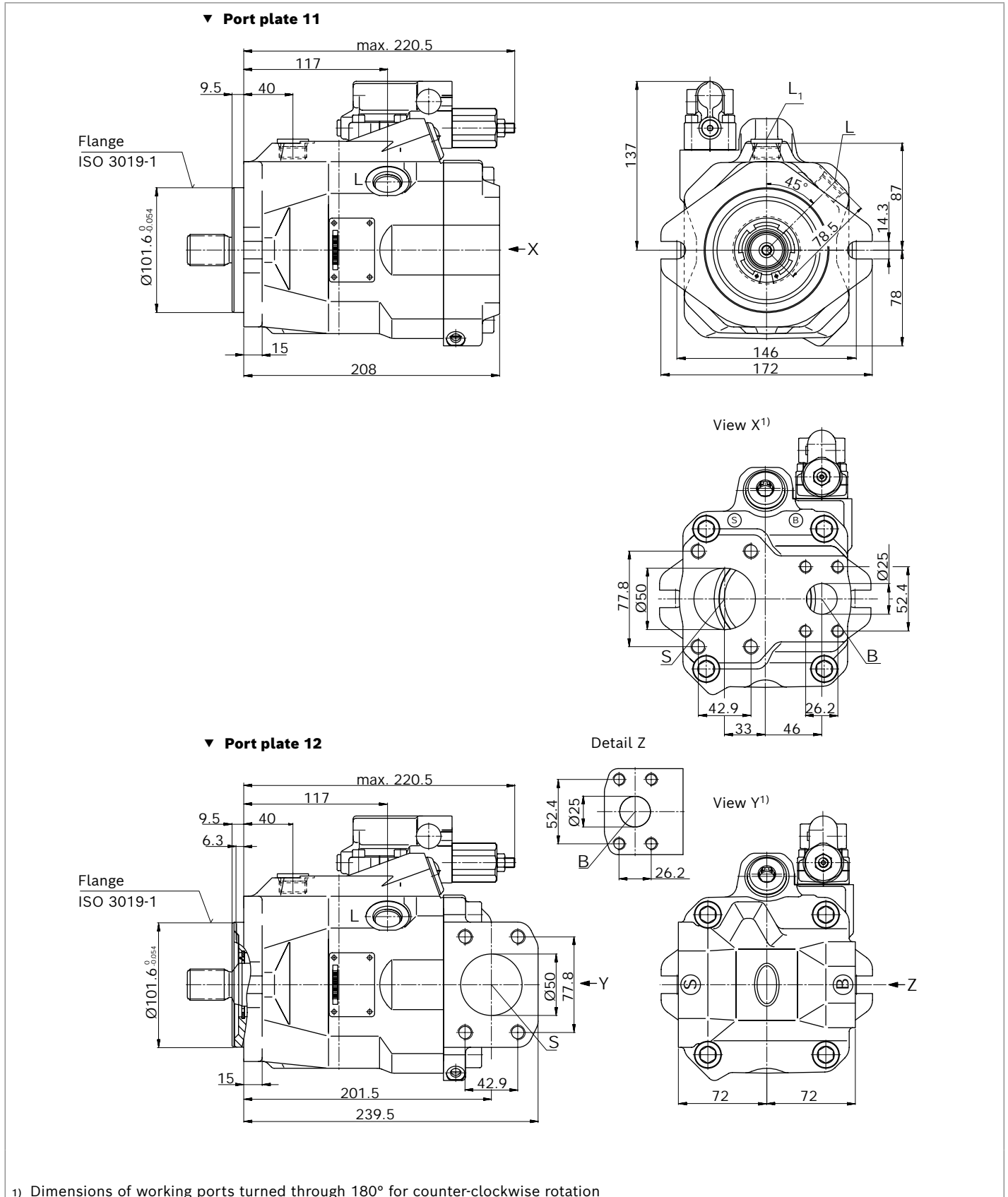

1) Dimensions of working ports turned through 180° for counter-clockwise rotation

## Dimensions, size 60

### DR - Hydraulic pressure controller; Clockwise rotation, mounting flange D series 52

#### ▼ Port plate 11

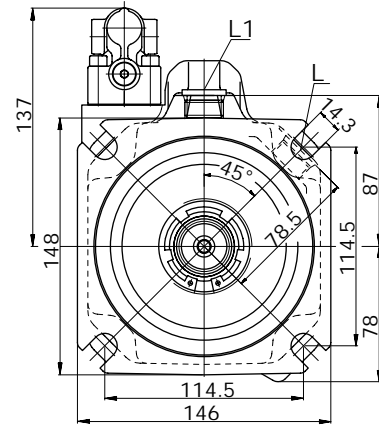
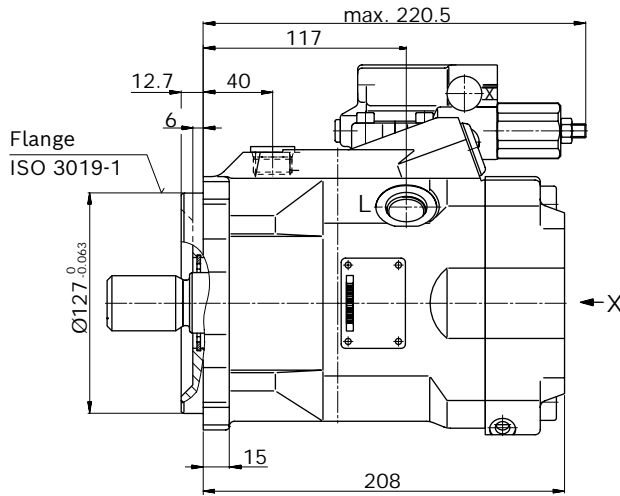

#### View X<sup>1)</sup>

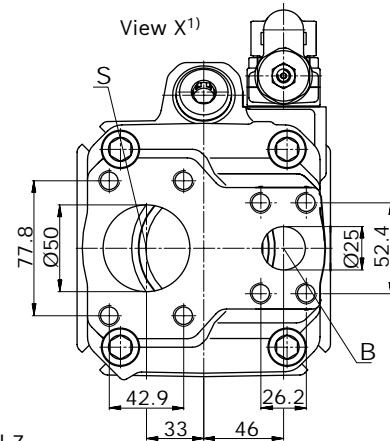

#### ▼ Port plate 12

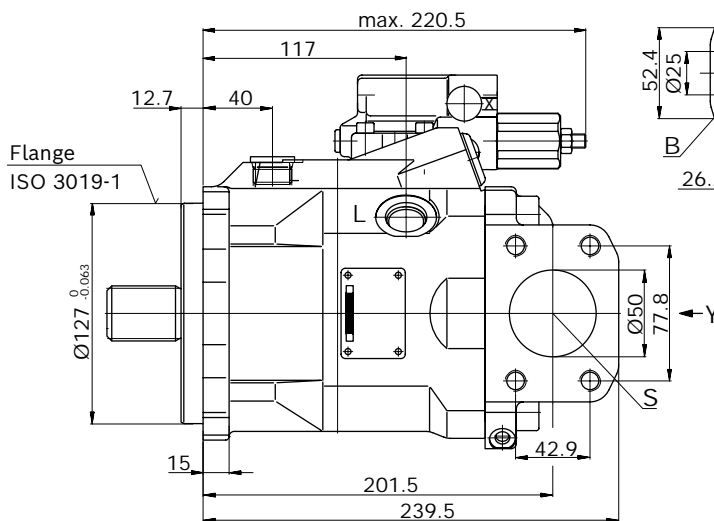

#### Detail Z

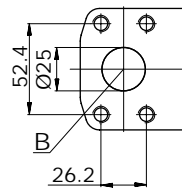

#### View Y<sup>1)</sup>

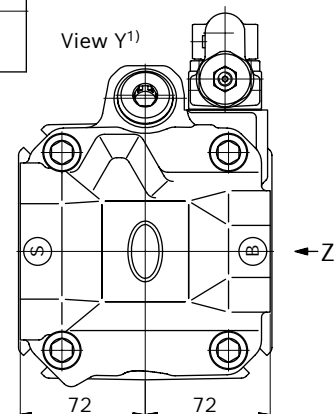

1) Dimensions of working ports turned through 180° for counter-clockwise rotation

## Dimensions, size 63

### DR – Hydraulic pressure controller; Clockwise rotation, mounting flange C series 53

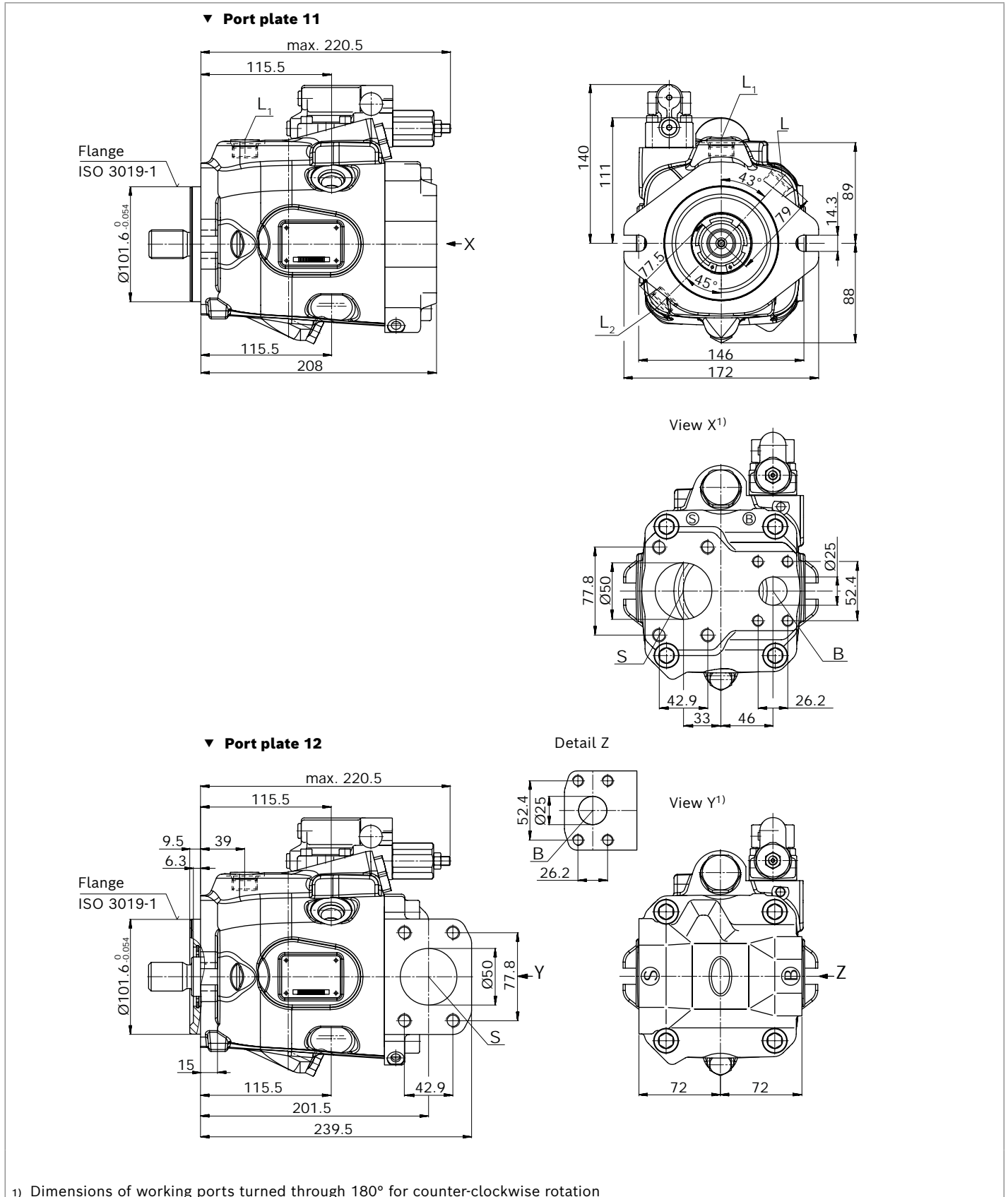

## Dimensions, size 63

### DR – Hydraulic pressure controller; Clockwise rotation, mounting flange D series 53

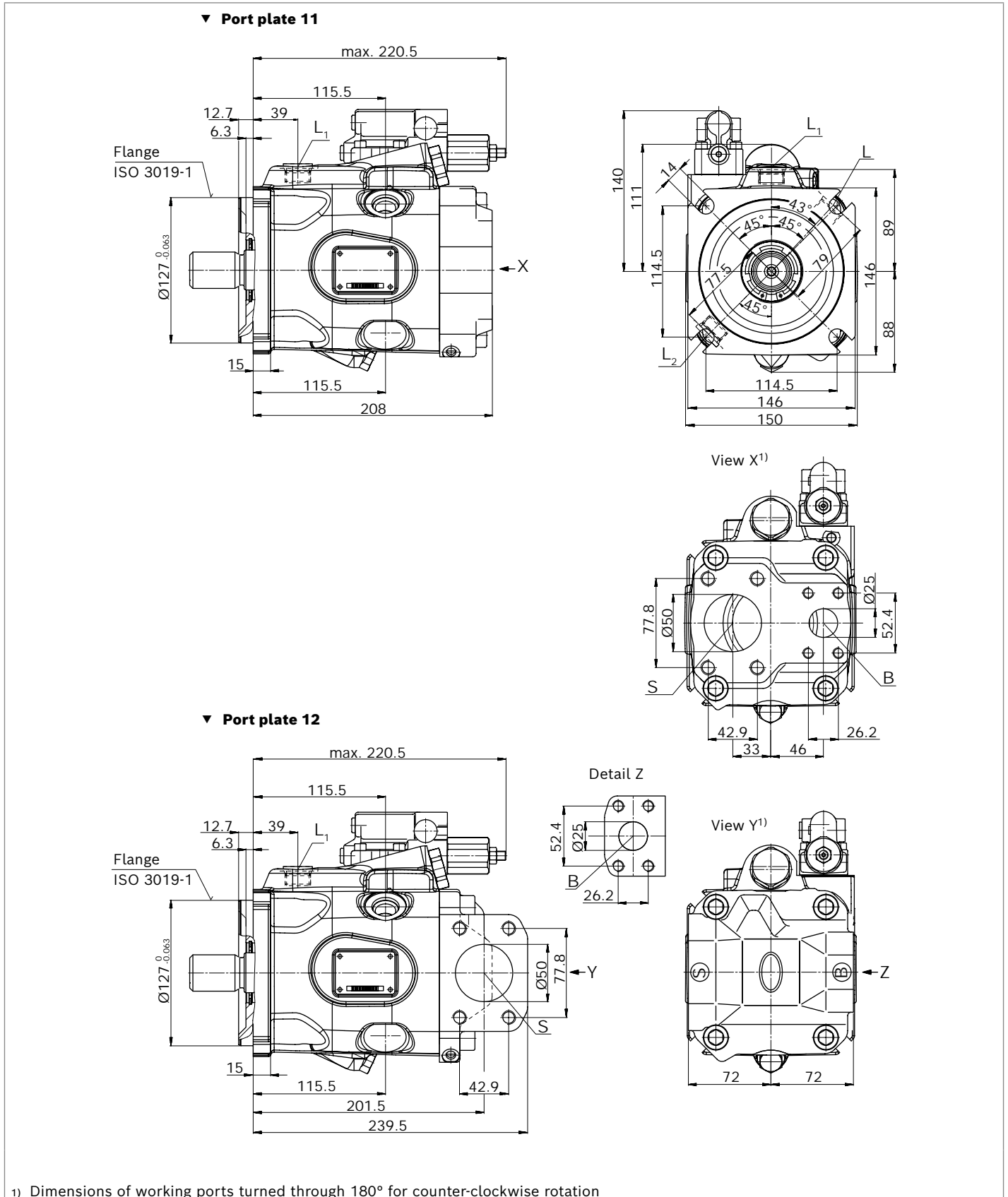

▼ **Splined shaft 1 1/4 in (32-4, ISO 3019-1)**

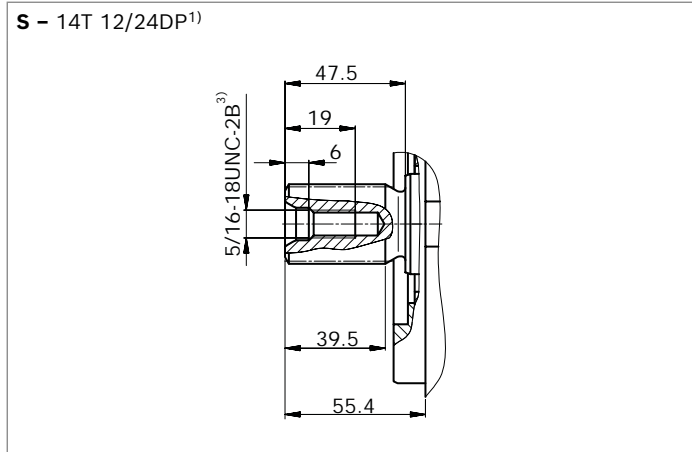

▼ **Splined shaft 1 1/4 in (similar to ISO 3019-1)**

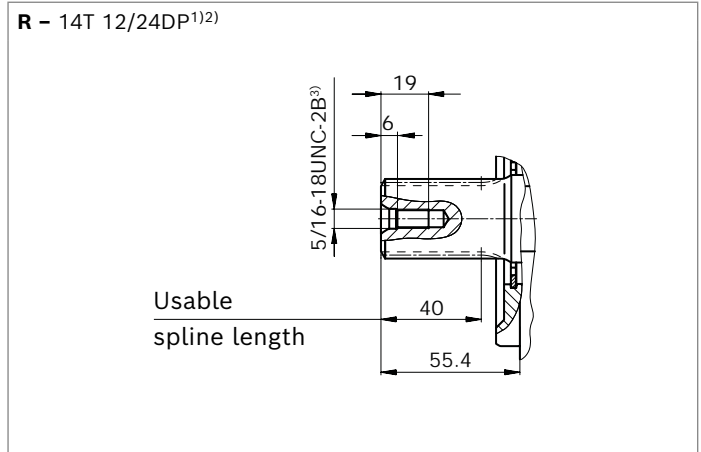

▼ **Splined shaft 1 in (25-4, ISO 3019-1)**

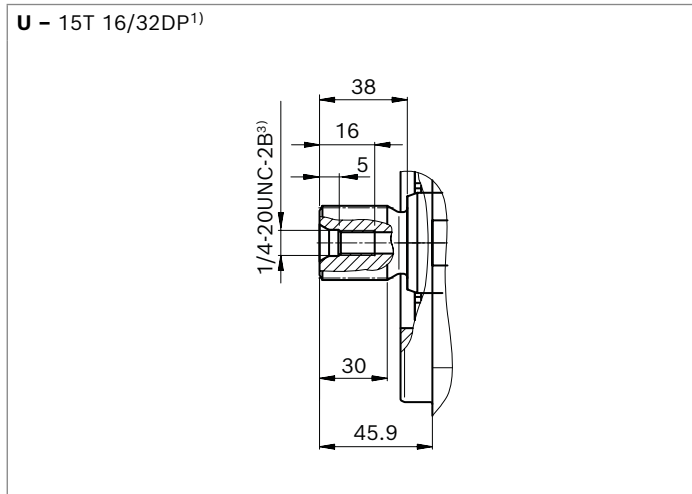

▼ **Splined shaft 1 in (similar to ISO 3019-1)**

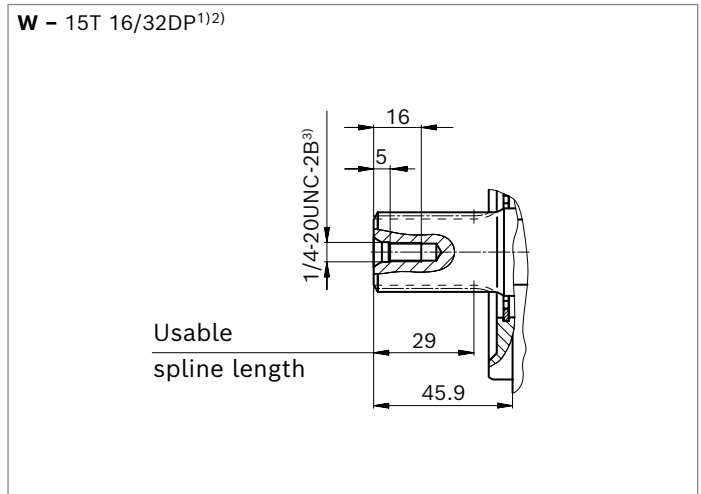

Ports		Standard	Size	$p_{max}$ [bar] <sup>4)</sup>	State <sup>8)</sup>
<b>B</b>	Working port (standard pressure series)	ISO 6162-1	1 in	315	O
	Fastening thread	DIN 13	M10 × 1.5; 17 deep		
<b>S</b>	Suction port (standard pressure series)	ISO 6162-1	2 in	5	O
	Fastening thread	DIN 13	M12 × 1.75; 20 deep		
<b>L</b>	Drain port	ISO 11926 <sup>5)</sup>	7/8-14UNF-2B; 13 deep	2	O <sup>6)</sup>
<b>L<sub>1</sub>, L<sub>2</sub></b> <sup>7)</sup>	Drain port	ISO 11926 <sup>5)</sup>	7/8-14UNF-2B; 13 deep	2	X <sup>6)</sup>
<b>X</b>	Pilot pressure	ISO 11926	7/16-20UNF-2A; 11.5 deep	315	O

1) Involute spline according to ANSI B92.1a, 30° pressure angle, flat root, side fit, tolerance class 5  
 2) Splines according to ANSI B92.1a, spline runout is a deviation from standard ISO 3019-1.  
 3) Thread according to ASME B1.1  
 4) Depending on the application, momentary pressure peaks can occur.  
 Keep this in mind when selecting measuring devices and fittings.

5) The countersink may be deeper than specified in the standard.  
 6) Depending on the installation position, **L**, **L<sub>1</sub>** or **L<sub>2</sub>** must be connected (also see installation instructions starting on page 69).  
 7) Only series 53  
 8) O = Must be connected (plugged on delivery)  
 X = Plugged (in normal operation)

▼ **DRG – Pressure controller, remotely controlled, series 52**

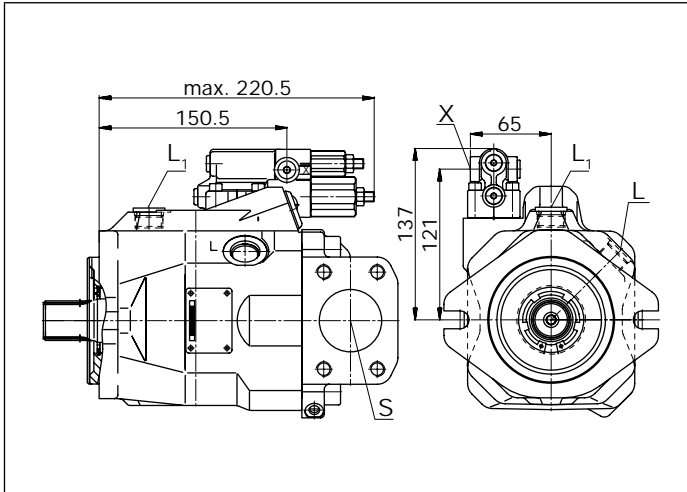

▼ **DFR/DFR1/DRSC – Pressure and flow controller, series 52**

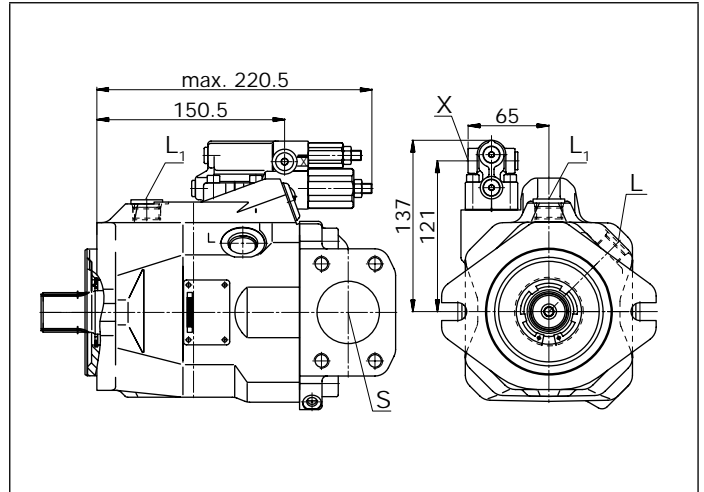

▼ **ED7. / ER7. – Electro-prop. Pressure control, series 52**

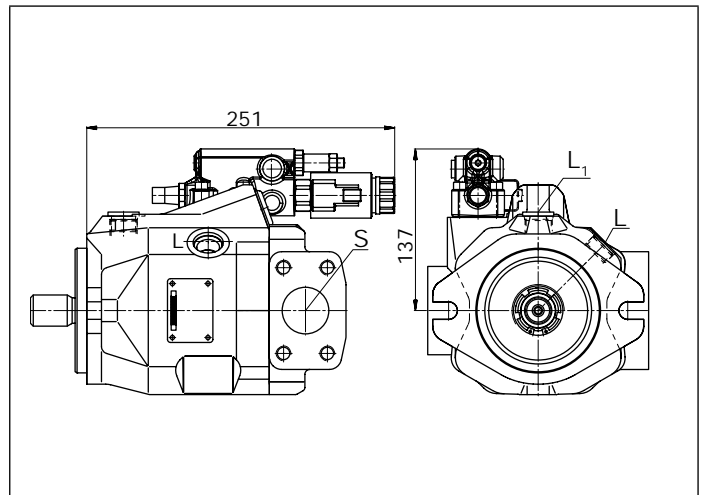

▼ **DRG – Pressure controller, remotely controlled, series 53**

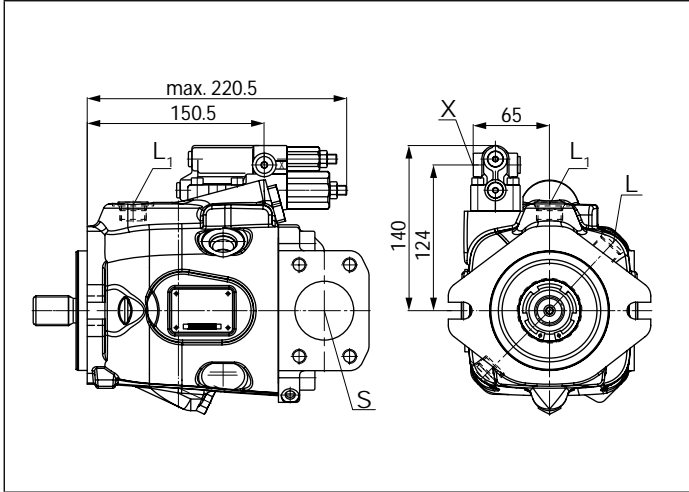

▼ **EP.D. / EK.D. – Electro-proportional control, series 53**

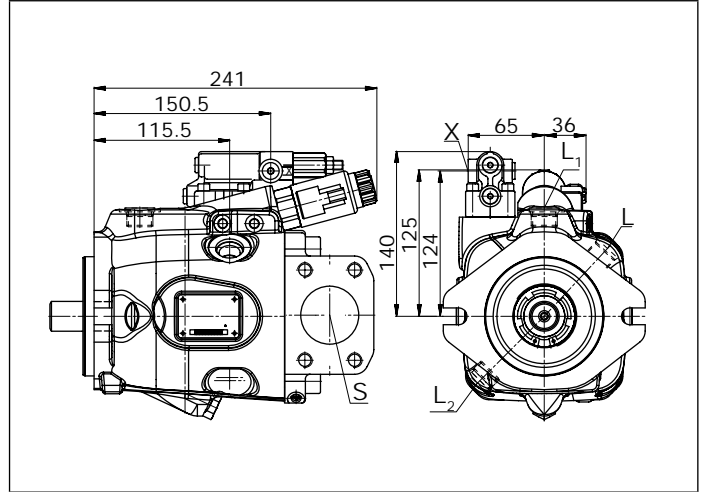

▼ **DRF/DRS/DRSC – Pressure and flow controller, Series 53**

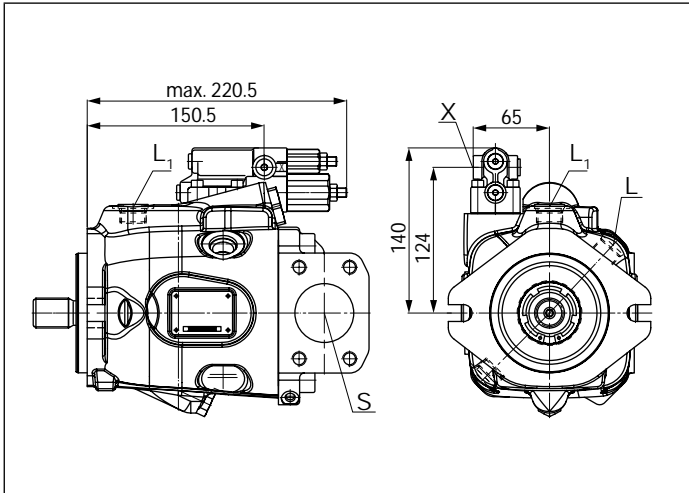

▼ **EP.ED. / EK.ED. – Electro-prop. control, series 53**

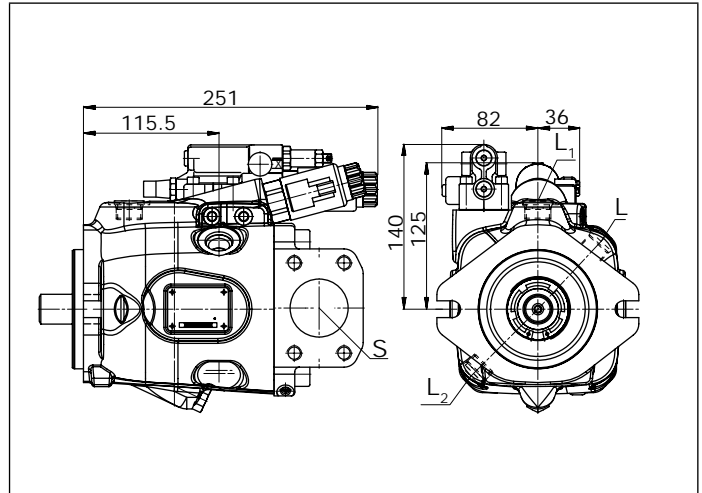

▼ **LA.D. – Pressure, flow and power controller, series 53**

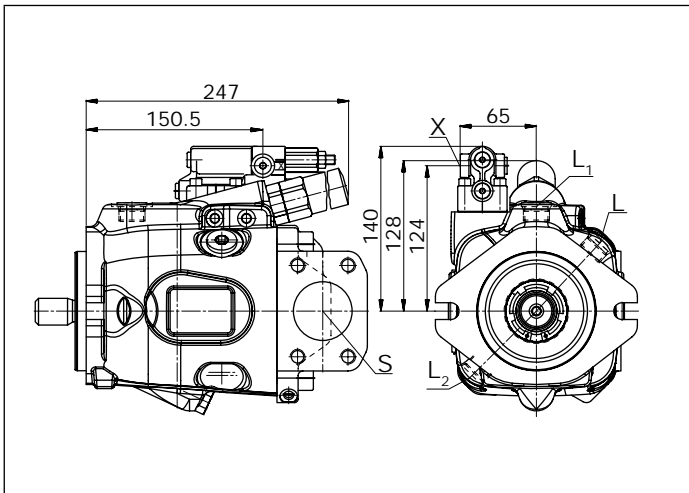

▼ **ED7. / ER7. – Electro-prop. Pressure control, series 53**

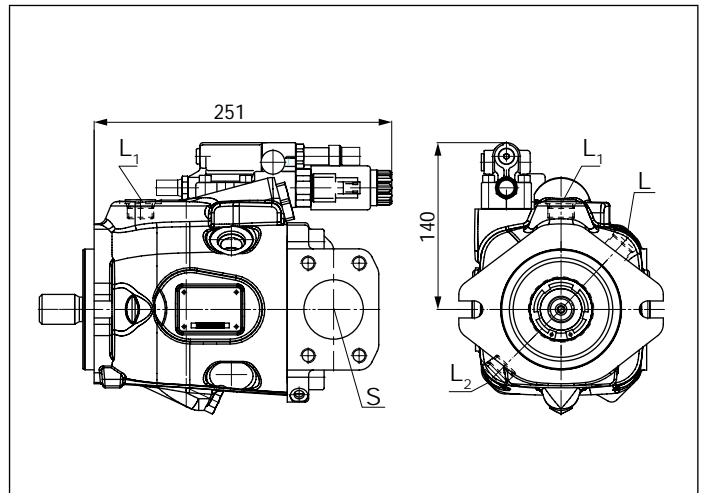

## Dimensions, size 72

### DR – Hydraulic pressure controller; Clockwise rotation, mounting flange C series 53

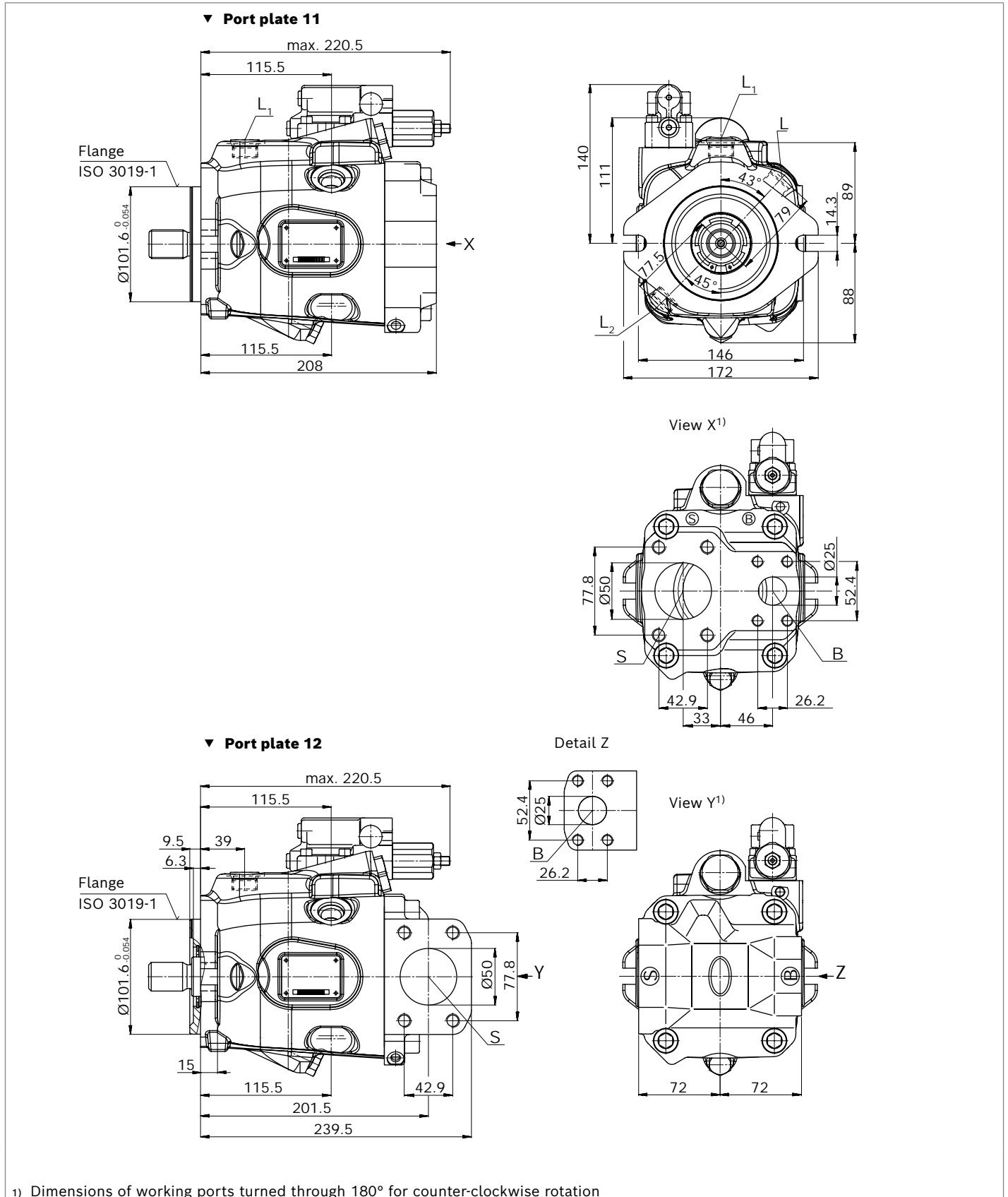

## Dimensions, size 72

### DR - Hydraulic pressure controller; Clockwise rotation, mounting flange D series 53

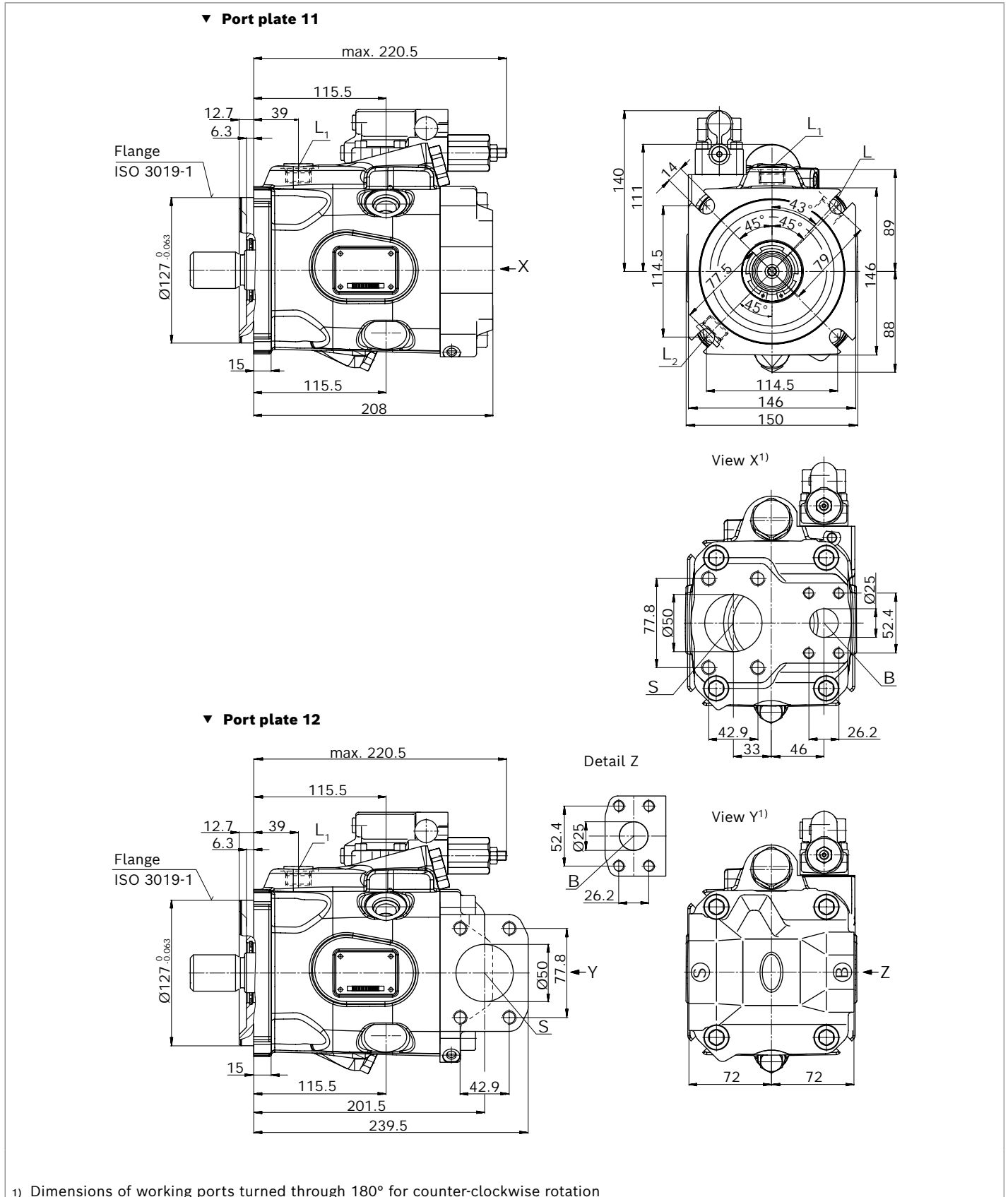

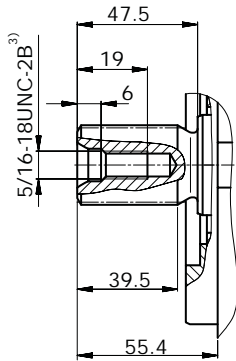
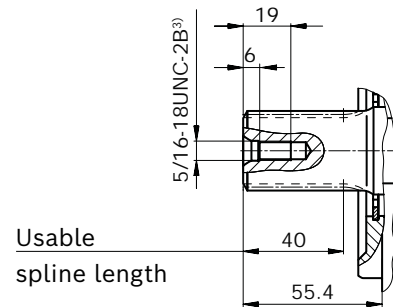
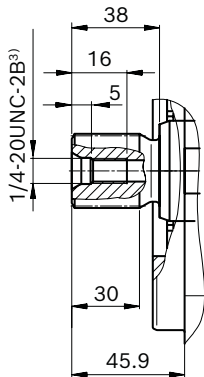
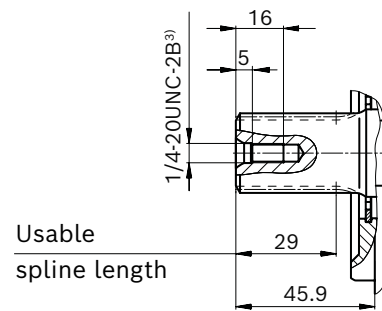
**▼ Splined shaft 1 1/4 in (32-4, ISO 3019-1)**
**S** – 14T 12/24DP<sup>1)</sup>

**▼ Splined shaft 1 1/4 in (similar to ISO 3019-1)**
**R** – 14T 12/24DP<sup>1)2)</sup>

**▼ Splined shaft 1 in (25-4, ISO 3019-1)**
**U** – 15T 16/32DP<sup>1)</sup>

**▼ Splined shaft 1 in (similar to ISO 3019-1)**
**W** – 15T 16/32DP<sup>1)2)</sup>

Ports		Standard	Size	$p_{max}$ [bar] <sup>4)</sup>	State <sup>8)</sup>
<b>B</b>	Working port (standard pressure series)	ISO 6162-1	1 in	315	O
	Fastening thread	DIN 13	M10 × 1.5; 17 deep		
<b>S</b>	Suction port (standard pressure series)	ISO 6162-1	2 in	5	O
	Fastening thread	DIN 13	M12 × 1.75; 20 deep		
<b>L</b>	Drain port	ISO 11926 <sup>5)</sup>	7/8-14UNF-2B; 13 deep	2	O <sup>6)</sup>
<b>L<sub>1</sub>, L<sub>2</sub><sup>7)</sup></b>	Drain port	ISO 11926 <sup>5)</sup>	7/8-14UNF-2B; 13 deep	2	X <sup>6)</sup>
<b>X</b>	Pilot pressure	ISO 11926	7/16-20UNF-2A; 11.5 deep	315	O

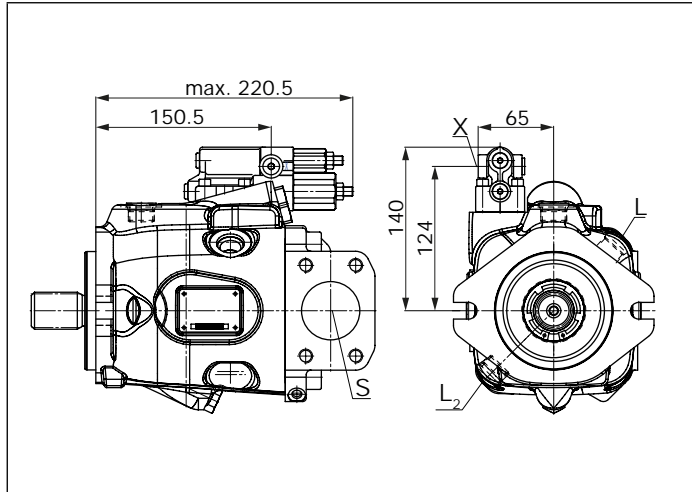
1) Involute spline according to ANSI B92.1a, 30° pressure angle, flat root, side fit, tolerance class 5  
 2) Splines according to ANSI B92.1a, spline runout is a deviation from standard ISO 3019-1.  
 3) Thread according to ASME B1.1  
 4) Depending on the application, momentary pressure peaks can occur.  
 Keep this in mind when selecting measuring devices and fittings.

5) The countersink may be deeper than specified in the standard.  
 6) Depending on the installation position, **L**, **L<sub>1</sub>** or **L<sub>2</sub>** must be connected (also see installation instructions starting on page 69).  
 7) Only series 53  
 8) O = Must be connected (plugged on delivery)  
 X = Plugged (in normal operation)

▼ **DRG – Pressure controller, remotely controlled, series 53**



▼ **EP.D. / EK.D. – Electro-proportional control, series 53**

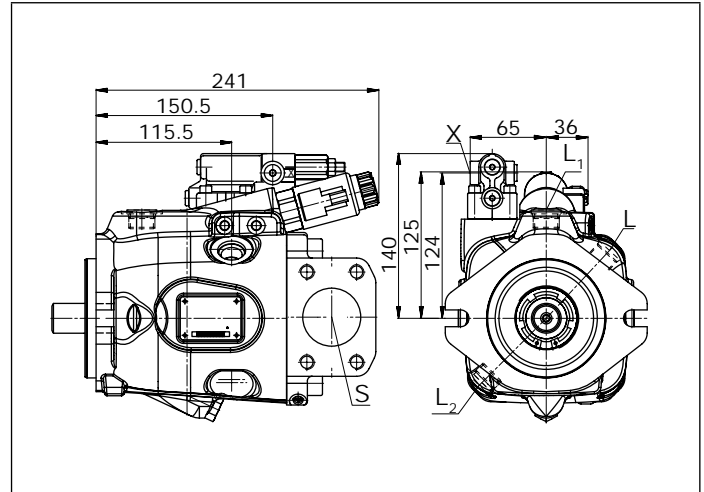

▼ **DRF/DRS/DRSC – Pressure and flow controller, series 53**

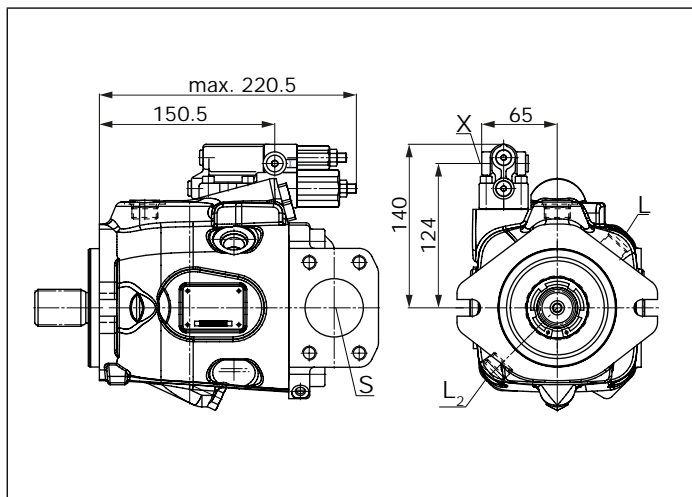

▼ **EP.ED. / EK.ED. – Electro-prop. control, series 53**

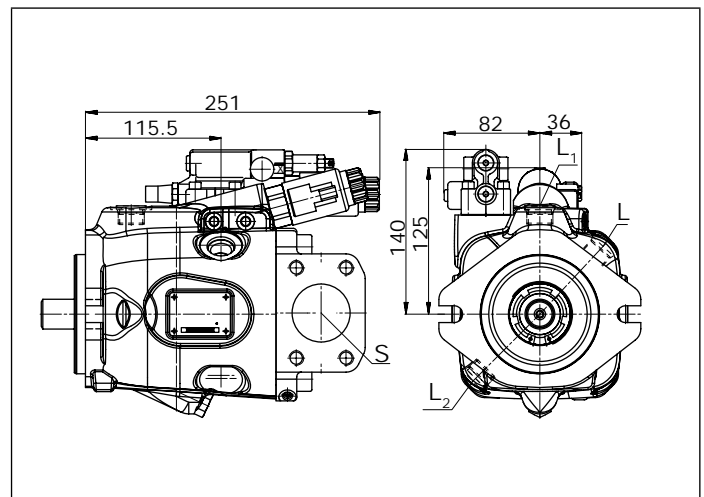

▼ **LA.D. – Pressure, flow and power controller, series 53**

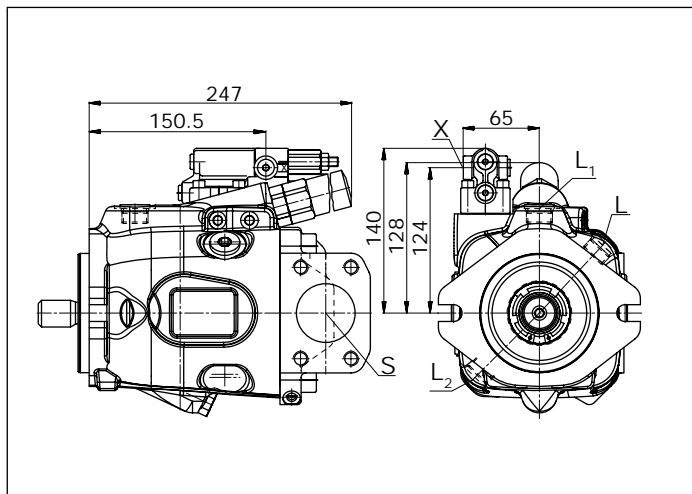

▼ **ED7. / ER7. – Electro-prop. Pressure control, series 53**

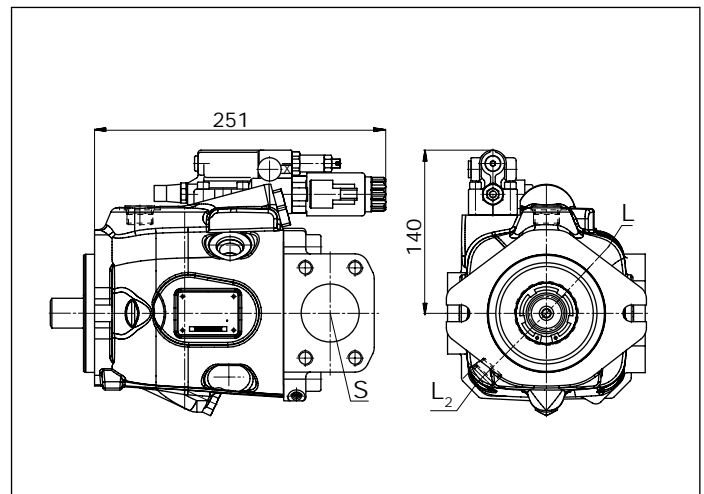

## Dimensions, size 85

### DR - Hydraulic pressure controller; Clockwise rotation, mounting flange C series 52

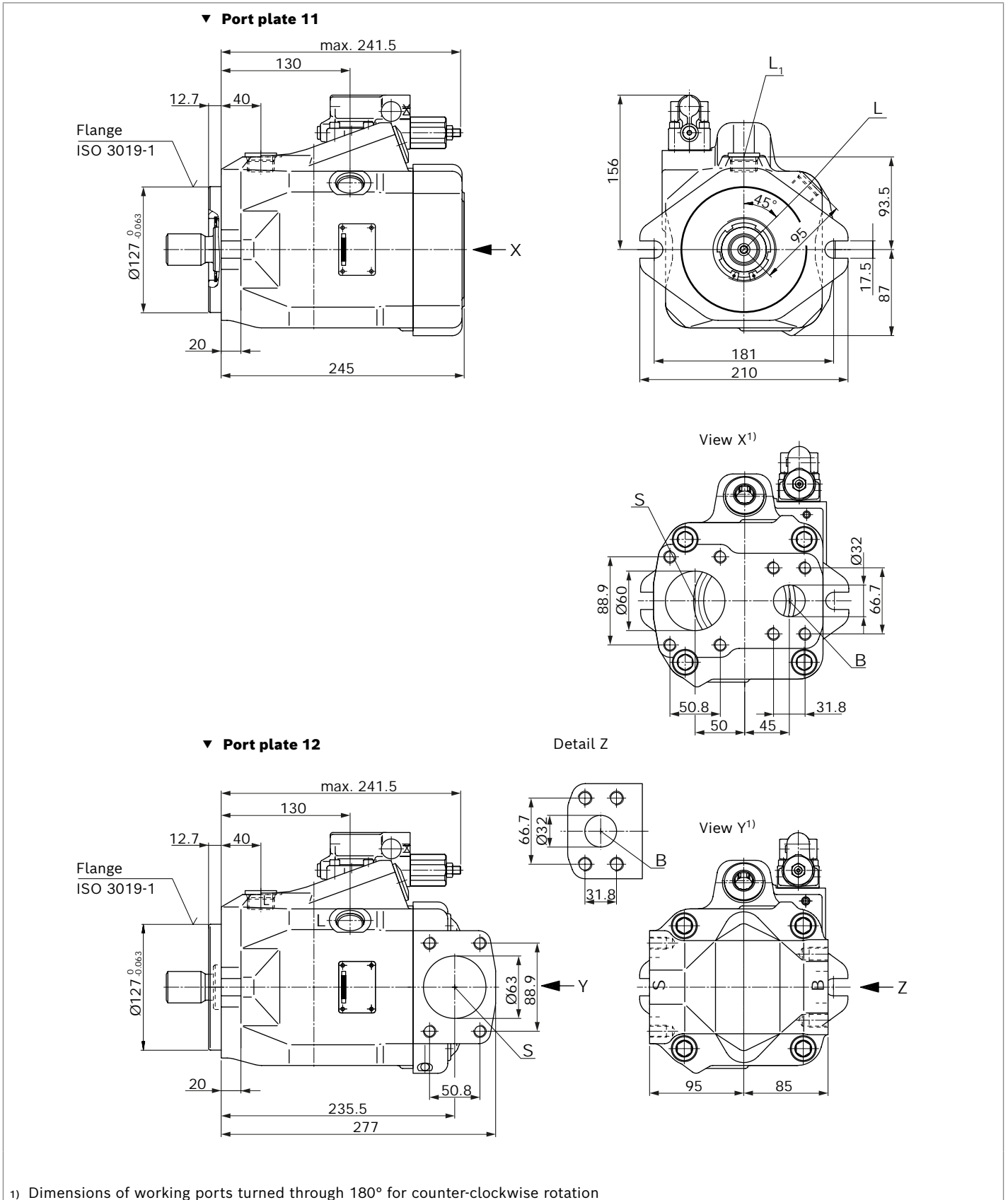

## Dimensions, size 85

### DR - Hydraulic pressure controller; Clockwise rotation, mounting flange C and D series 53

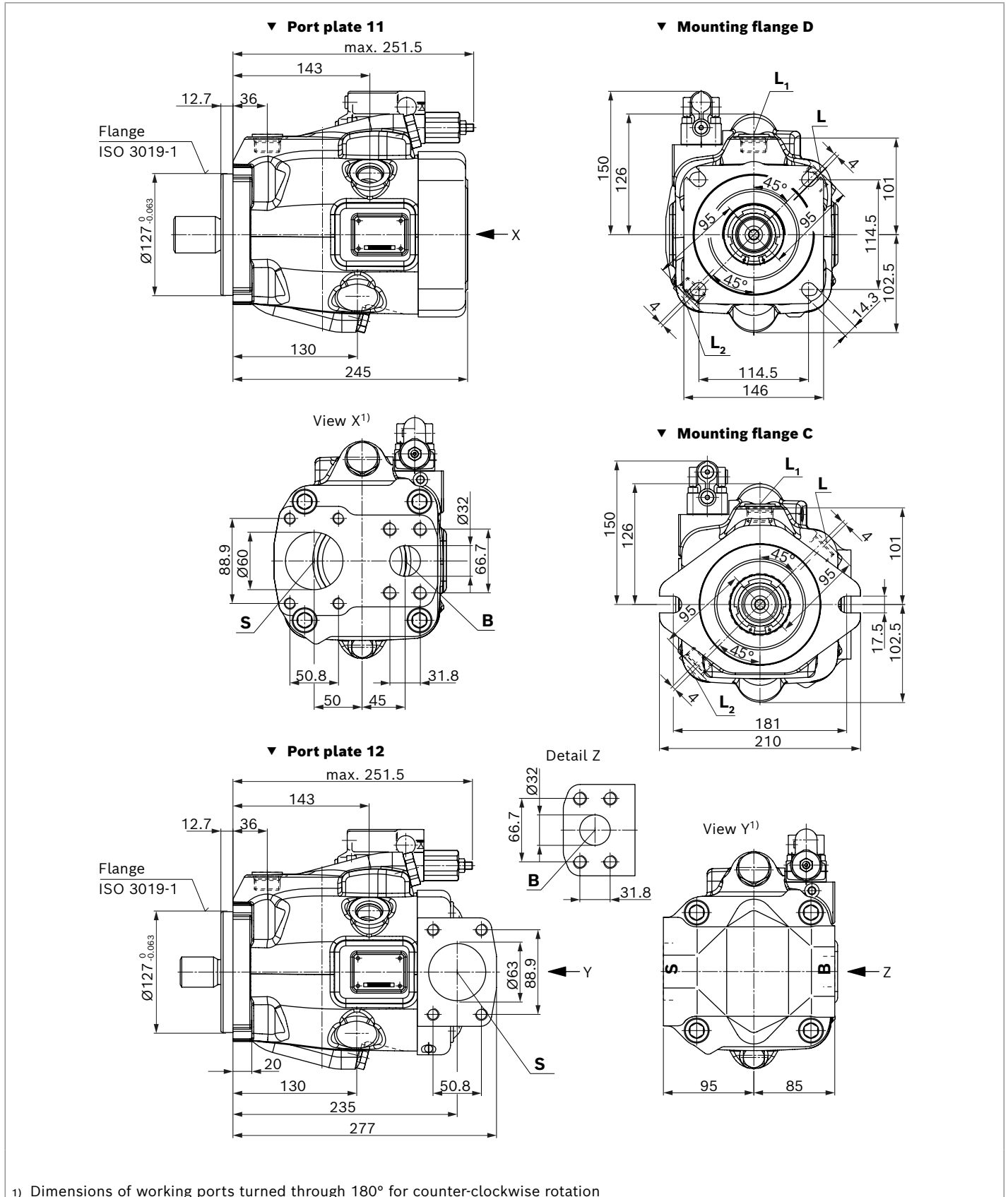

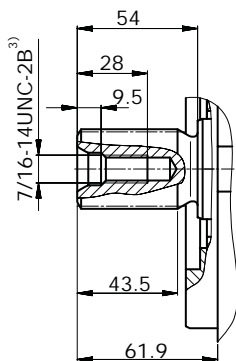
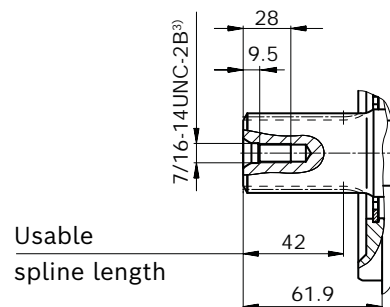
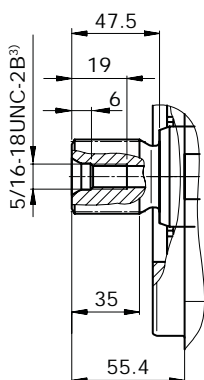
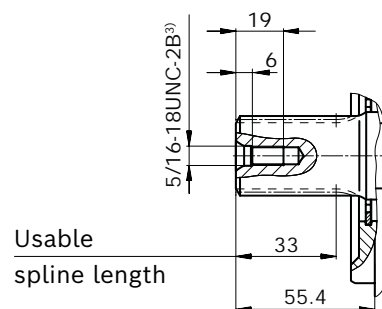
**▼ Splined shaft 1 1/2 in (38-4, ISO 3019-1)**
**S** – 17T 12/24DP<sup>1)</sup>

**▼ Splined shaft 1 1/2 in (similar to ISO 3019-1)**
**R** – 17T 12/24DP<sup>1)2)</sup>

**▼ Splined shaft 1 1/4 in (32-4, ISO 3019-1)**
**U** – 14T 12/24DP<sup>1)</sup>

**▼ Splined shaft 1 1/4 in (similar to ISO 3019-1)**
**W** – 14T 12/24DP<sup>1)2)</sup>

Ports		Standard	Size	$p_{max}$ [bar] <sup>4)</sup>	State <sup>8)</sup>
<b>B</b>	Working port (high-pressure series) Fastening thread	ISO 6162-2 DIN 13	1 1/4 in M14 × 2; 19 deep	315	O
<b>S</b>	Suction port (standard pressure series) Fastening thread	ISO 6162-1 DIN 13	2 1/2 in M12 × 1.75; 17 deep	5	O
<b>L</b>	Drain port	ISO 11926 <sup>5)</sup>	1 1/16-12UNF-2B; 15 deep	2	O <sup>6)</sup>
<b>L<sub>1</sub>, L<sub>2</sub></b> <sup>7)</sup>	Drain port	ISO 11926 <sup>5)</sup>	1 1/16-12UNF-2B; 15 deep	2	X <sup>6)</sup>
<b>X</b>	Pilot pressure	ISO 11926	7/16-20UNF-2A; 11.5 deep	315	O

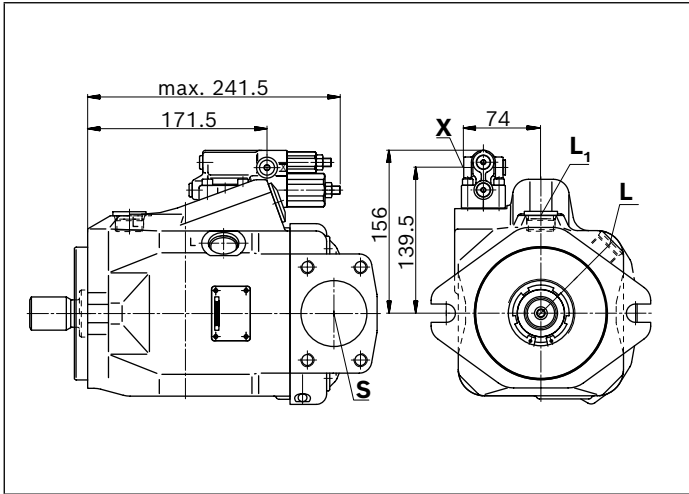
1) Involute spline according to ANSI B92.1a, 30° pressure angle, flat root, side fit, tolerance class 5  
 2) Splines according to ANSI B92.1a, spline runout is a deviation from standard ISO 3019-1.  
 3) Thread according to ASME B1.1  
 4) Depending on the application, momentary pressure peaks can occur.  
 Keep this in mind when selecting measuring devices and fittings.

5) The countersink may be deeper than specified in the standard.  
 6) Depending on the installation position, **L**, **L<sub>1</sub>** or **L<sub>2</sub>** must be connected (also see installation instructions starting on page 69).  
 7) Only series 53  
 8) O = Must be connected (plugged on delivery)  
 X = Plugged (in normal operation)

▼ **DRG – Pressure controller, remotely controlled, series 52**



▼ **DFR/DFR1/DRSC – Pressure and flow controller, series 52**

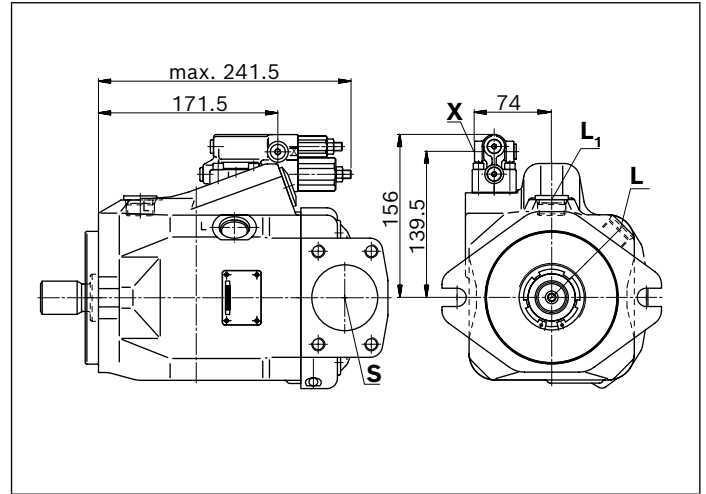

▼ **ED7. / ER7. – Electro-prop. Pressure control, series 52**

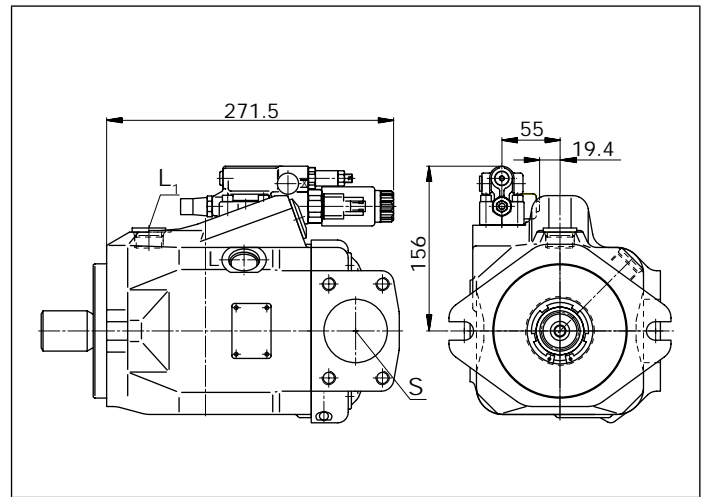

▼ **DRG - Pressure controller, remotely controlled, series 53**

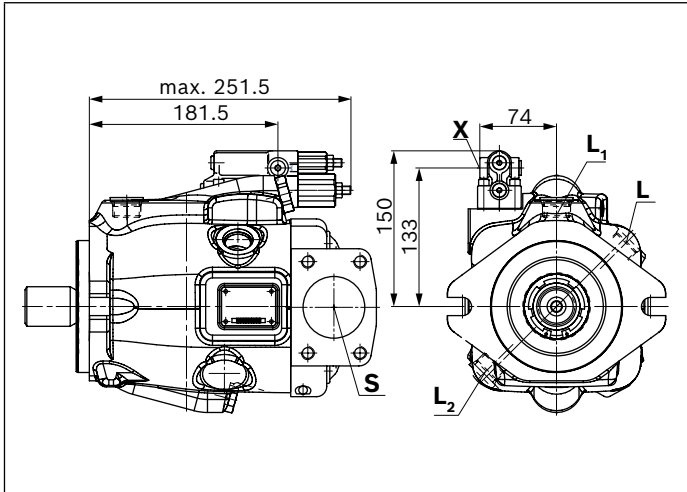

▼ **EP.D. / EK.D. - Electro-proportional control, series 53**

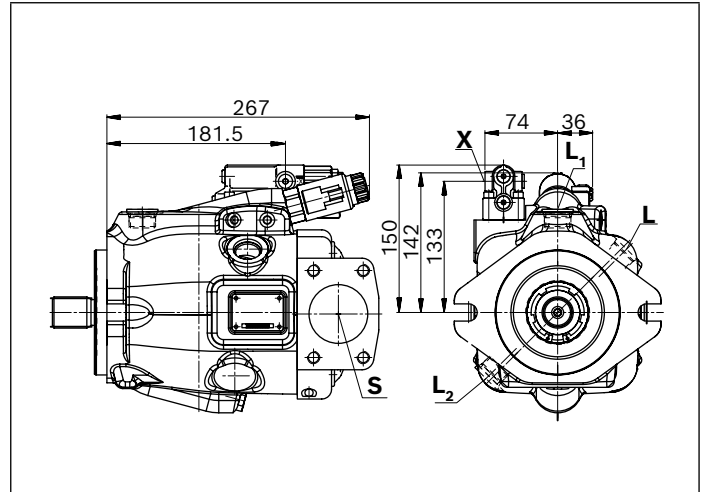

▼ **DRF/DRS/DRSC - Pressure and flow controller, series 53**

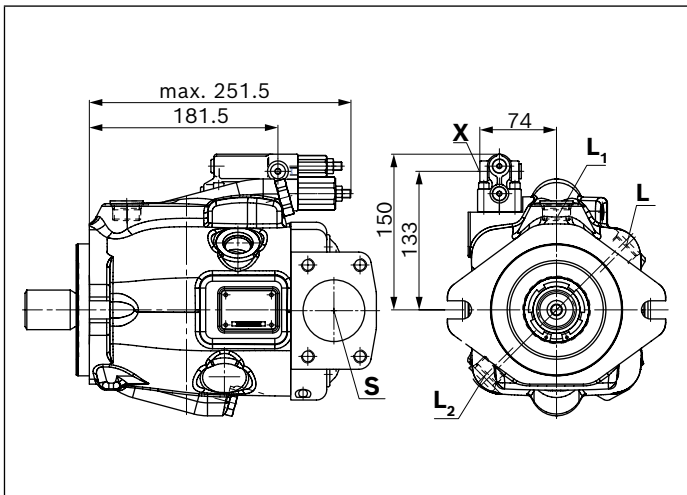

▼ **EP.ED. / EK.ED. - Electro-prop. control, series 53**

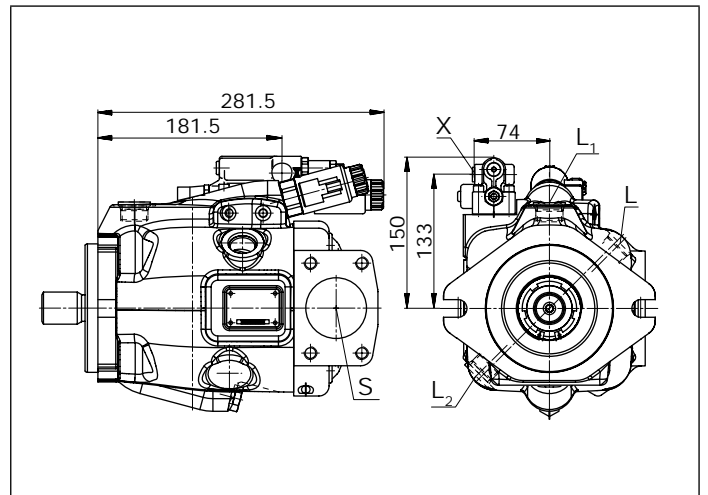

▼ **LA.D. - Pressure, flow and power controller, series 53**

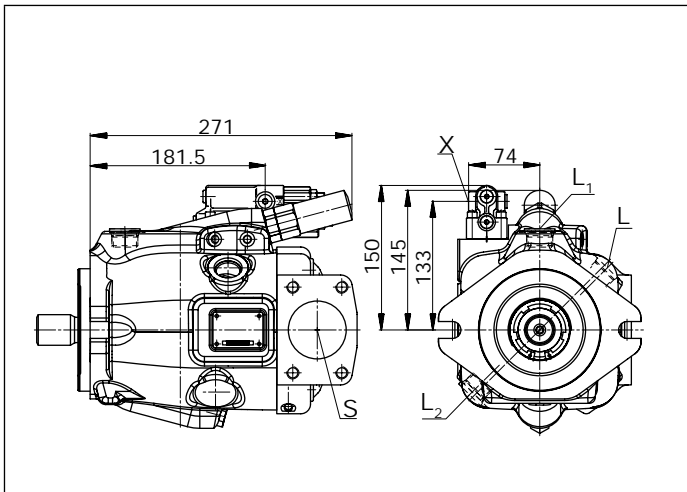

▼ **ED7. / ER7. - Electro-prop. Pressure control, series 53**

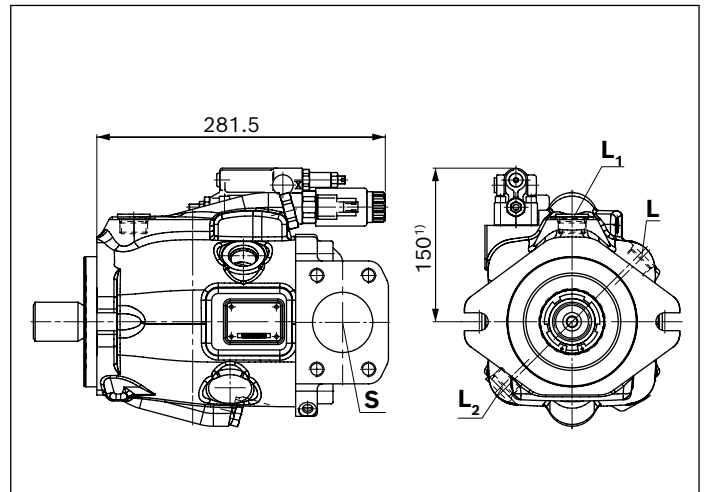

## Dimensions, size 100

### DR - Hydraulic pressure controller; Clockwise rotation, mounting flange C series 53

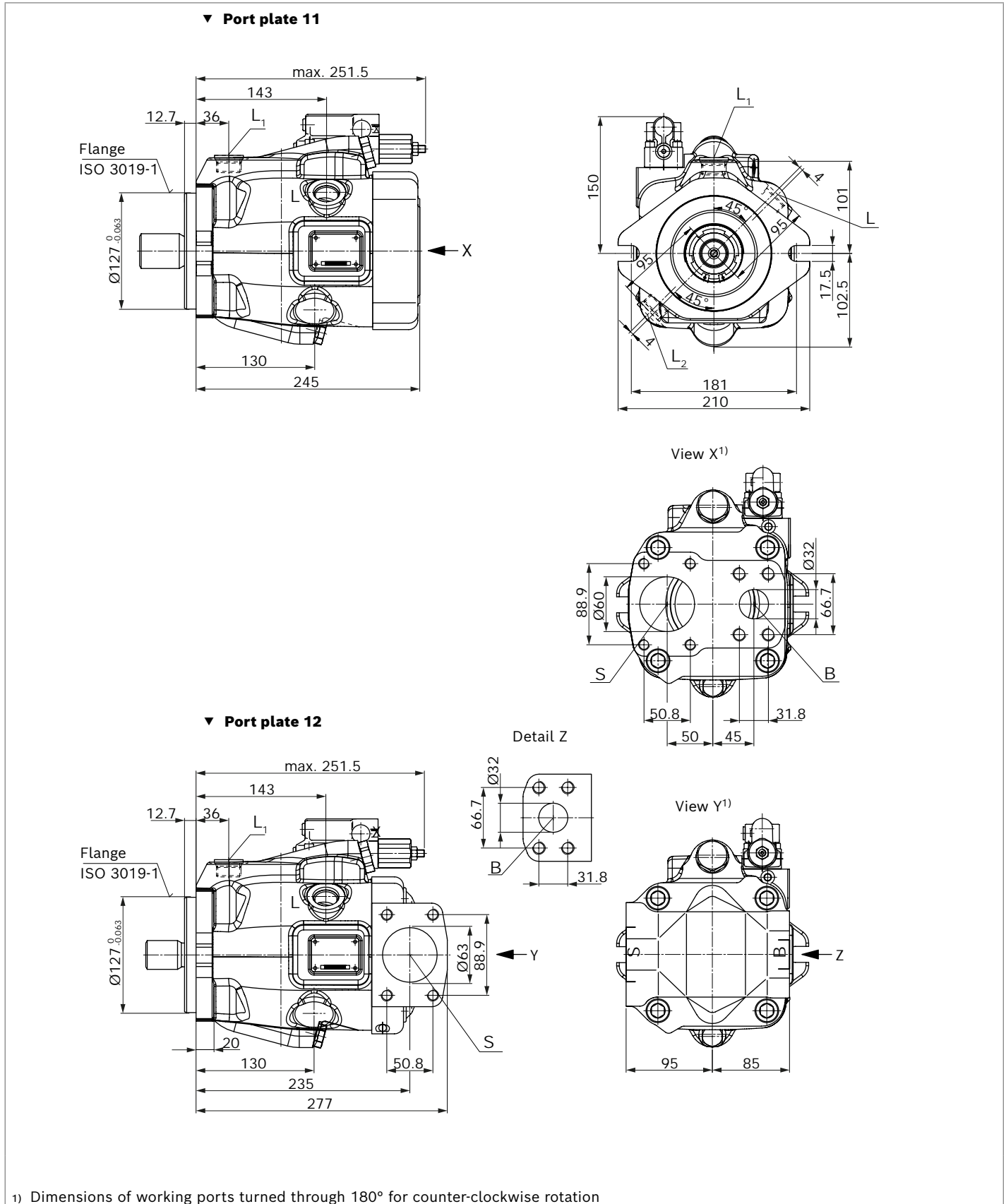

## Dimensions, size 100

### DR - Hydraulic pressure controller; Clockwise rotation, mounting flange D series 53

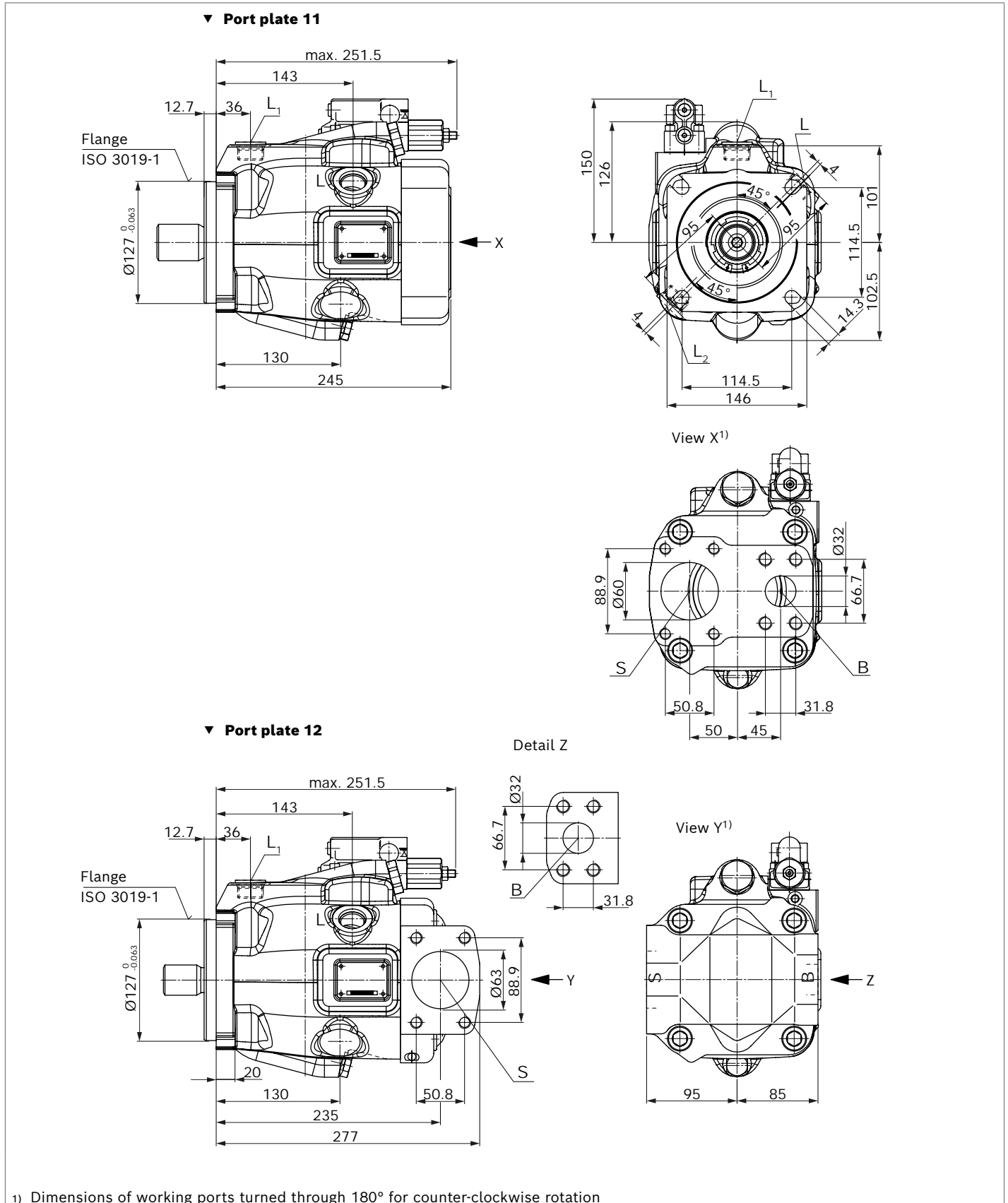

▼ **Splined shaft 1 1/2 in (38-4, ISO 3019-1)**

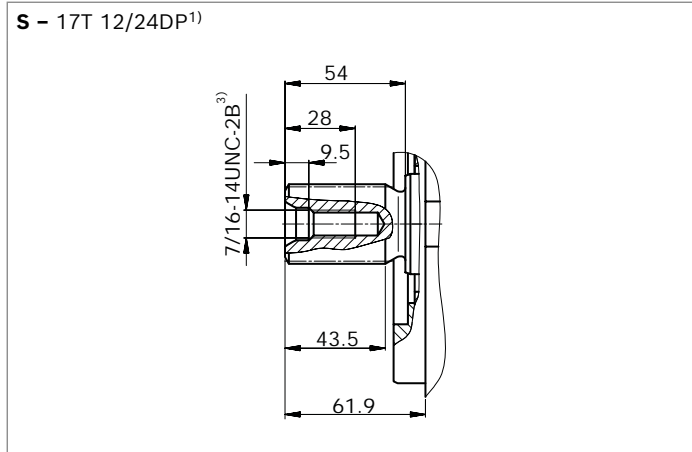

▼ **Splined shaft 1 1/2 in (similar to ISO 3019-1)**

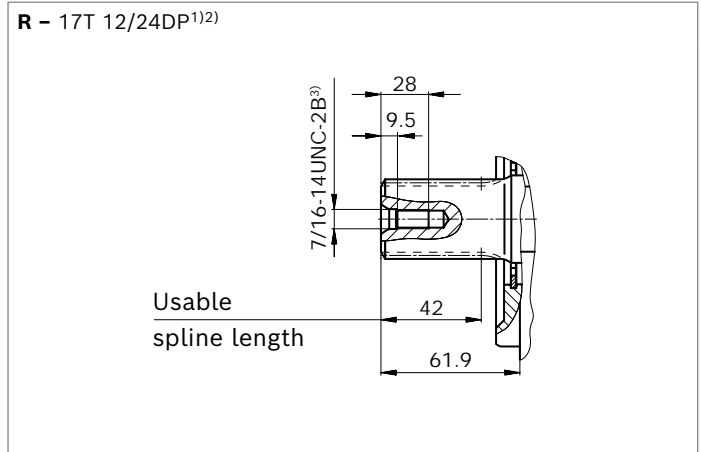

▼ **Splined shaft 1 1/4 in (32-4, ISO 3019-1)**

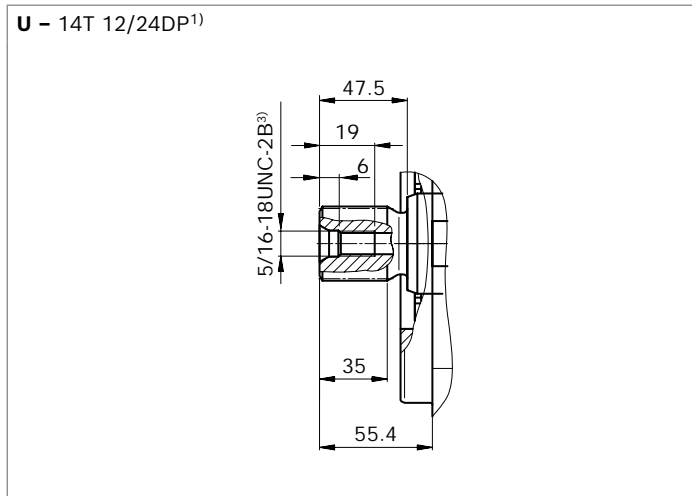

▼ **Splined shaft 1 1/4 in (similar to ISO 3019-1)**

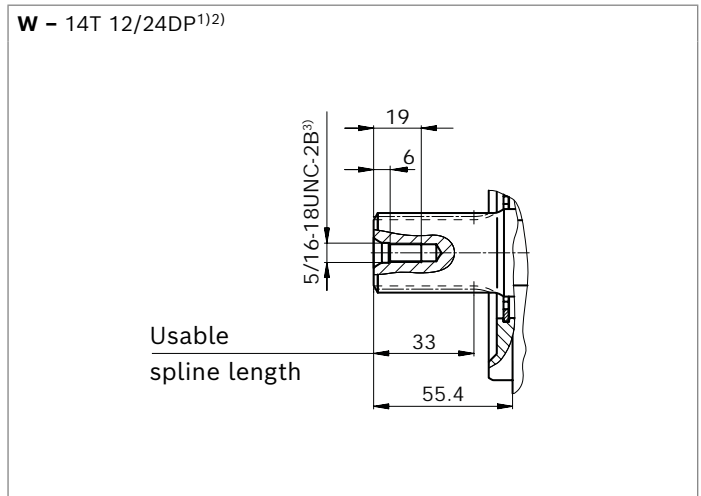

Ports	Standard	Size	$p_{max}$ [bar] <sup>4)</sup>	State <sup>8)</sup>
<b>B</b>	Working port (high-pressure series) Fastening thread	ISO 6162-2 DIN 13	1 1/4 in M14 × 2; 19 deep	315 O
<b>S</b>	Suction port (standard pressure series) Fastening thread	ISO 6162-1 DIN 13	2 1/2 in M12 × 1.75; 17 deep	5 O
<b>L</b>	Drain port	ISO 11926 <sup>5)</sup>	1 1/16-12UNF-2B; 15 deep	2 O <sup>6)</sup>
<b>L<sub>1</sub>, L<sub>2</sub></b> <sup>7)</sup>	Drain port	ISO 11926 <sup>5)</sup>	1 1/16-12UNF-2B; 15 deep	2 X <sup>6)</sup>
<b>X</b>	Pilot pressure	ISO 11926	7/16-20UNF-2A; 11.5 deep	315 O

1) Involute spline according to ANSI B92.1a, 30° pressure angle, flat root, side fit, tolerance class 5  
 2) Splines according to ANSI B92.1a, spline runout is a deviation from standard ISO 3019-1.  
 3) Thread according to ASME B1.1  
 4) Depending on the application, momentary pressure peaks can occur.  
 Keep this in mind when selecting measuring devices and fittings.

5) The countersink may be deeper than specified in the standard.  
 6) Depending on the installation position, **L**, **L<sub>1</sub>** or **L<sub>2</sub>** must be connected (also see installation instructions starting on page 69).  
 7) Only series 53  
 8) O = Must be connected (plugged on delivery)  
 X = Plugged (in normal operation)

▼ **DRG - Pressure controller, remotely controlled, series 53**

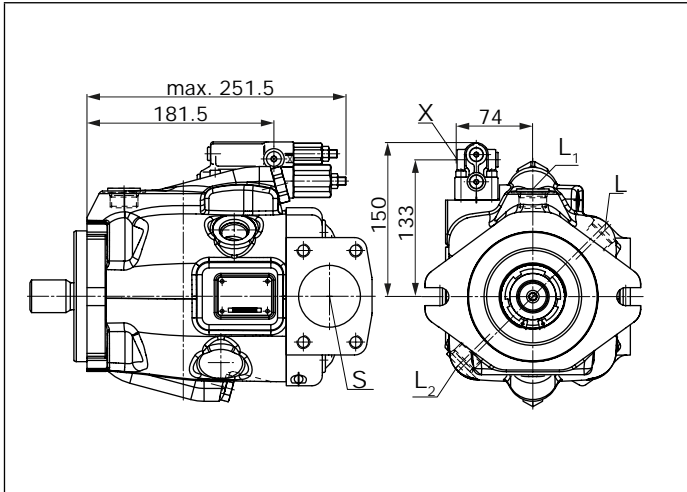

▼ **EP.D. / EK.D. - Electro-proportional control, series 53**

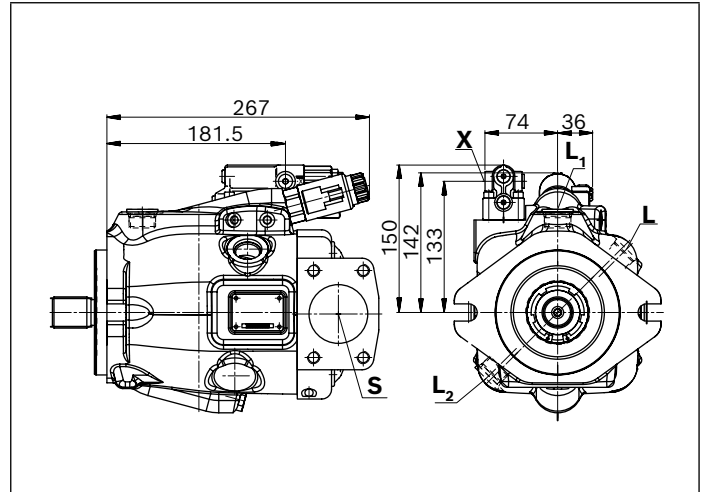

▼ **DRF/DRS/DRSC - Pressure and flow controller, series 53**

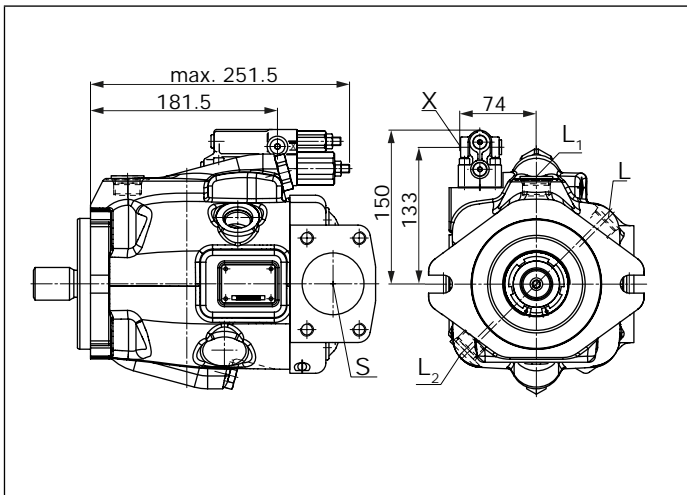

▼ **EP.ED. / EK.ED. - Electro-prop. control, series 53**

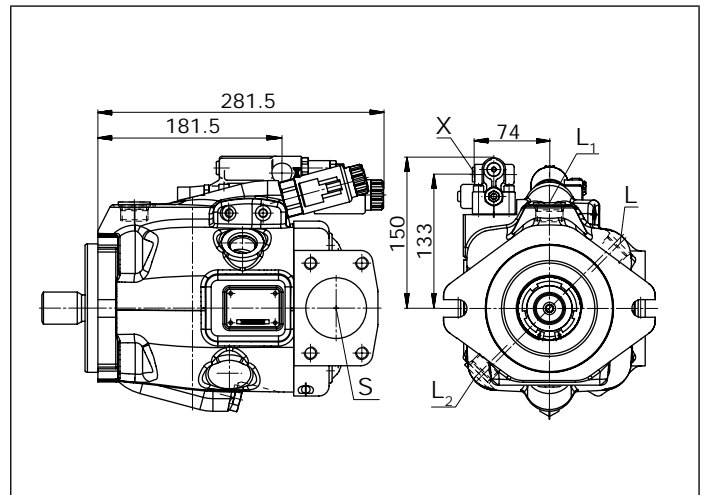

▼ **LA.D. - Pressure, flow and power controller, series 53**

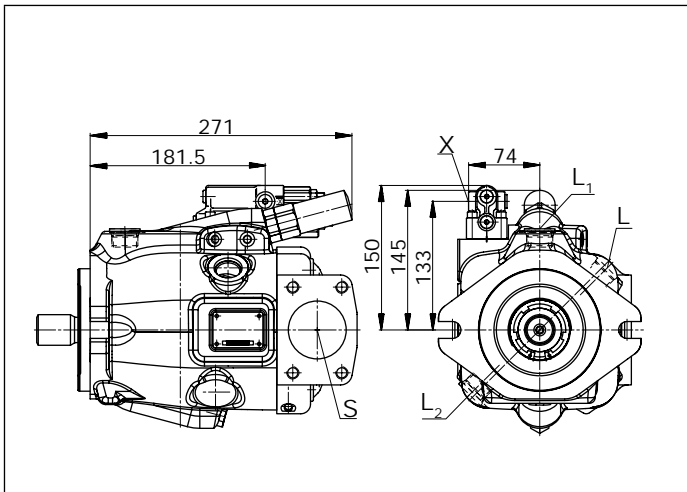

▼ **ED7. / ER7. - Electro-prop. Pressure control, series 53**

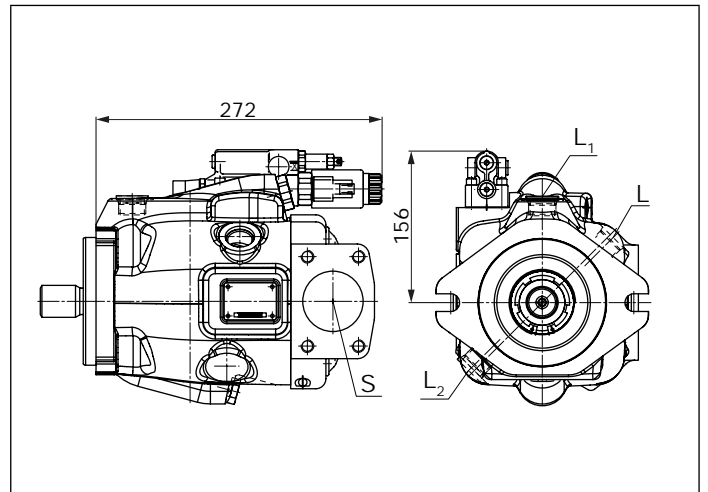

## Dimensions, through drive

Flange ISO 3019-1 (SAE)		Hub for splined shaft <sup>1)</sup>		Availability across sizes						Code	
Diameter	Mounting <sup>2)</sup>	Diameter		18	28	45	60/63	72	85		100
82-2 (A)	ø, ∞	5/8 in	9T 16/32DP	●	●	●	●	●	●	●	K01
		3/4 in	11T 16/32DP	●	●	●	●	●	●	●	K52

● = Available    ○ = On request

### 82-2

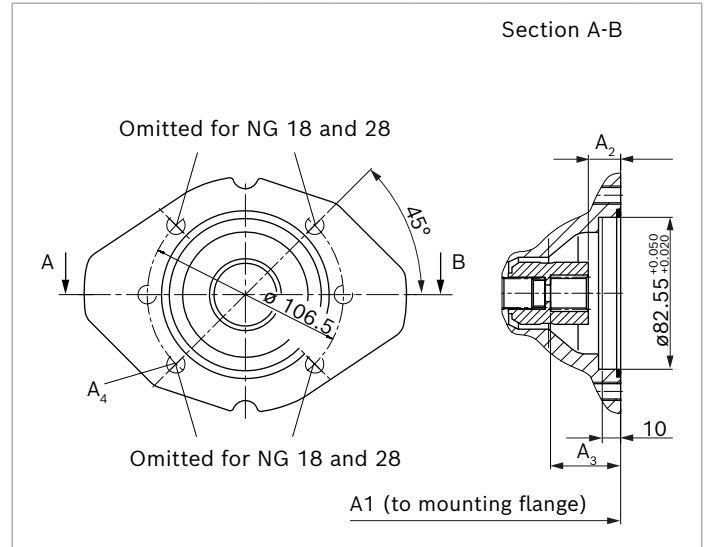
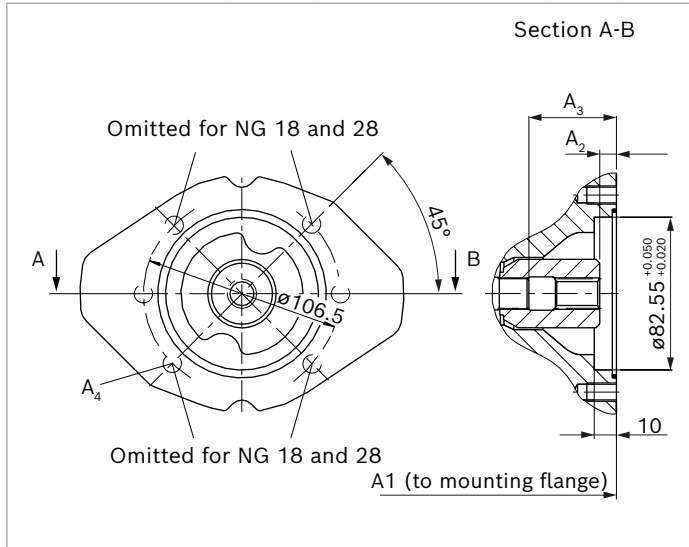

K01 (SAE J744 16-4 (A))	NG	A1	A2 <sup>4)</sup>	A3 <sup>4)</sup>	A4 <sup>3)</sup>
	18	182	9.3	42.5	M10 × 1.5; 14.5 deep
	28	204	9.2	36.2	M10 × 1.5; 16 deep
	45	229	10	52.7	M10 × 1.5; 16 deep
	60/ 63	255	8.7	58.2	M10 × 1.5; 16 deep
	72	255	8.7	58.2	M10 × 1.5; 16 deep
	85	302	12.5	67.2	M10 × 1.5; 20 deep
	100	302	12.5	67.2	M10 × 1.5; 20 deep

K52 (SAE J744 19-4 (A-B))	NG	A1	A2 <sup>4)</sup>	A3 <sup>4)</sup>	A4 <sup>3)</sup>
	18	182	18.3	39.3	M10 × 1.5; 14.5 deep
	28	204	18.4	39.4	M10 × 1.5; 16 deep
	45	229	18.4	39.4	M10 × 1.5; 16 deep
	60/ 63	255	18.4	39.4	M10 × 1.5; 16 deep
	72	255	18.4	39.4	M10 × 1.5; 16 deep
	85	302	21.5	42.5	M10 × 1.5; 20 deep
	100	302	21.5	42.5	M10 × 1.5; 20 deep

1) According to ANSI B92.1a, 30° pressure angle, flat root, side fit, tolerance class 5

2) Mounting holes pattern viewed on through drive with control at top

3) Thread according to DIN 13.

4) Minimum dimensions

Flange ISO 3019-1 (SAE)		Hub for splined shaft <sup>1)</sup>		Availability across sizes							Code
Diameter	Mounting <sup>2)</sup>	Diameter		18	28	45	60/63	72	85	100	
101-2 (B)	♂, ∞	7/8 in	13T 16/32DP	-	●	●	●	●	●	●	K68
		1 in	15T 16/32DP	-	-	●	●	●	●	●	K04

● = Available    ○ = On request

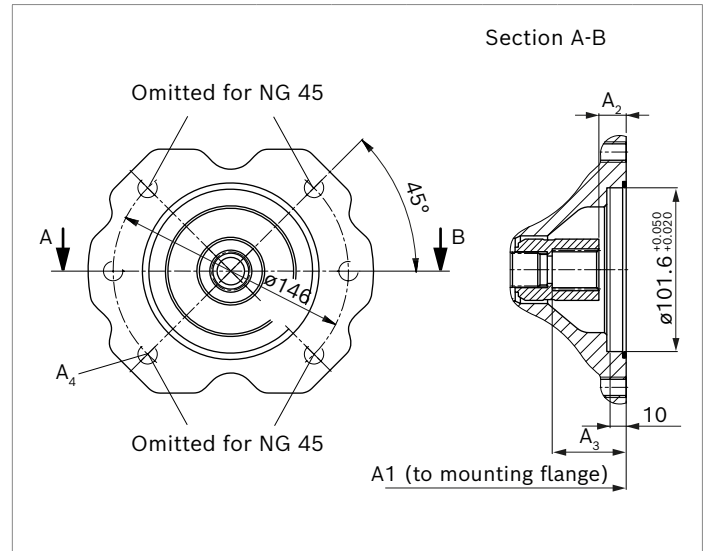
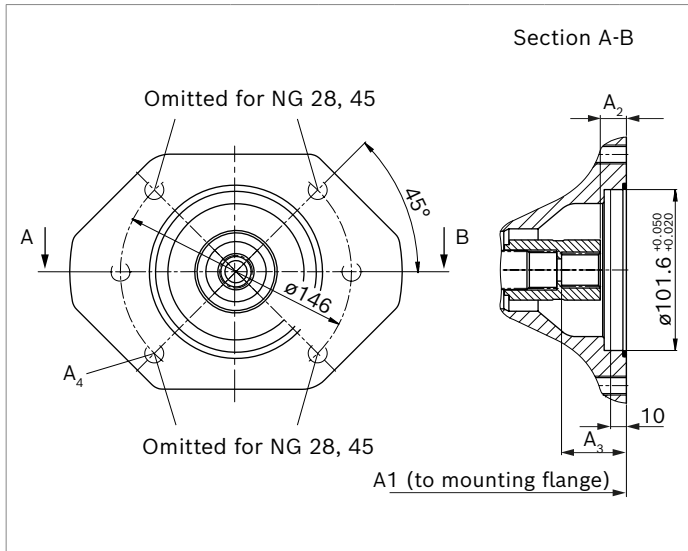
**101-2**

<b>K68</b> (SAE J744 22-4 (B))	NG	A1	A2 <sup>4)</sup>	A3 <sup>4)</sup>	A4 <sup>3)</sup>
	28	204	17.4	42.4	M12 × 1.75; 18 deep
	45	229	17.4	42.4	M12 × 1.75; 18 deep
	60/ 63	255	17.4	42.4	M12 × 1.75; 18 deep
	72	255	17.4	42.4	M12 × 1.75; 18 deep
	85	302	20.5	45.5	M12 × 1.75; 20 deep
	100	302	20.5	45.5	M12 × 1.75; 20 deep

<b>K04</b> (SAE J744 25-4 (B-B))	NG	A1	A2 <sup>4)</sup>	A3 <sup>4)</sup>	A4 <sup>3)</sup>
	45	229	17.9	47.4	M12 × 1.75; 18 deep
	60/ 63	255	17.9	47.4	M12 × 1.75; 18 deep
	72	255	17.9	47.4	M12 × 1.75; 18 deep
	85	302	20.7	50.2	M12 × 1.75; 20 deep
	100	302	20.7	50.2	M12 × 1.75; 20 deep

1) According to ANSI B92.1a, 30° pressure angle, flat root, side fit, tolerance class 5

2) Mounting holes pattern viewed on through drive with control at top

3) Thread according to DIN 13.

4) Minimum dimensions

Flange ISO 3019-1 (SAE)		Hub for splined shaft <sup>1)</sup>	Availability across sizes							Code
Diameter	Mounting <sup>2)</sup>	Diameter	18	28	45	60/63	72	85	100	
127-4 (C)		1 1/4 in 14T 12/24DP	-	-	-	●	●	●	●	K15
		1 1/2 in 17T 12/24DP	-	-	-	-	-	●	●	K16

● = Available    ○ = On request

**127-4**

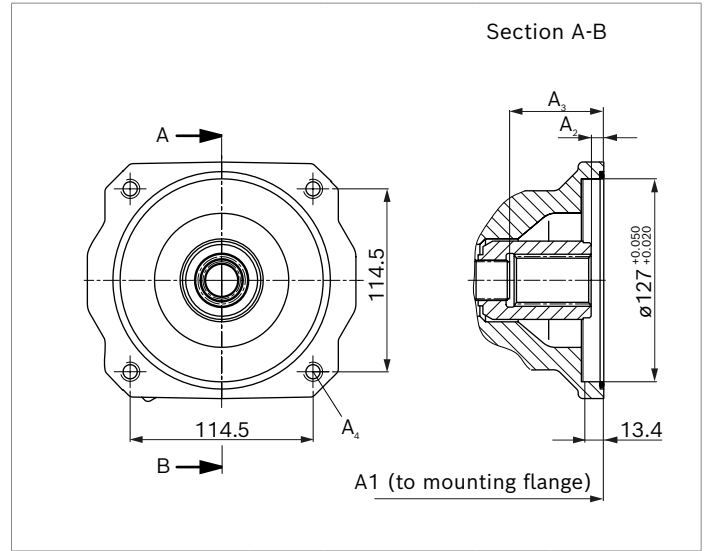
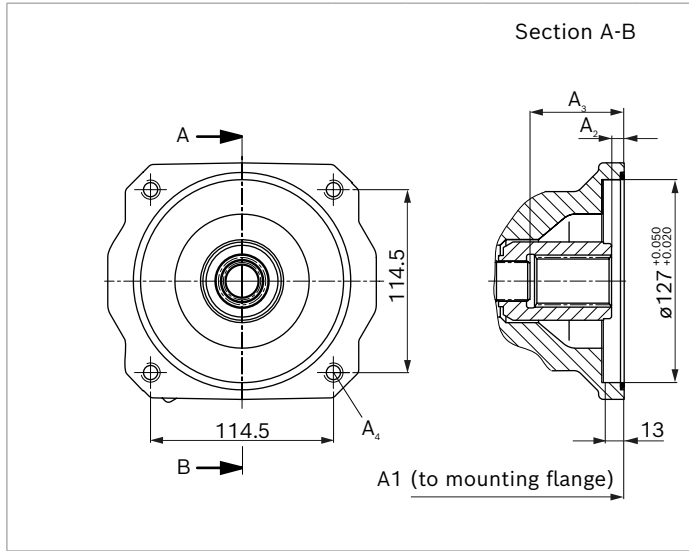

K15 (SAE J744 32-4 (C))	NG	A1	A2 <sup>4)</sup>	A3 <sup>4)</sup>	A4 <sup>3)</sup>
60/ 63	255	17.9	55.9	M12 × 1.75; 16 deep	
72	255	17.9	55.9	M12 × 1.75; 16 deep	
85	301.5	22	60	M12 × 1.75; through	
100	301.5	22	60	M12 × 1.75; through	

K16 (SAE J744 32-4 (C))	NG	A1	A2 <sup>4)</sup>	A3 <sup>4)</sup>	A4 <sup>3)</sup>
85	301.5	12.8	67.2	M12 × 1.75; through	
100	301.5	12.8	67.2	M12 × 1.75; through	

1) According to ANSI B92.1a, 30° pressure angle, flat root, side fit, tolerance class 5  
2) Mounting holes pattern viewed on through drive with control at top

3) Thread according to DIN 13.  
4) Minimum dimensions

Flange ISO 3019-1 (SAE)		Hub for splined shaft <sup>1)</sup>		Availability across sizes							Code
Diameter	Mounting <sup>2)</sup>	Diameter		18	28	45	60/63	72	85	100	
127-2 (B)	♂, ∞	1 1/4 in	14T 12/24DP	-	-	-	-	-	●	●	K07
		1 1/2 in	17T 12/24DP	-	-	-	-	-	●	●	K24

● = Available    ○ = On request

### 127-2

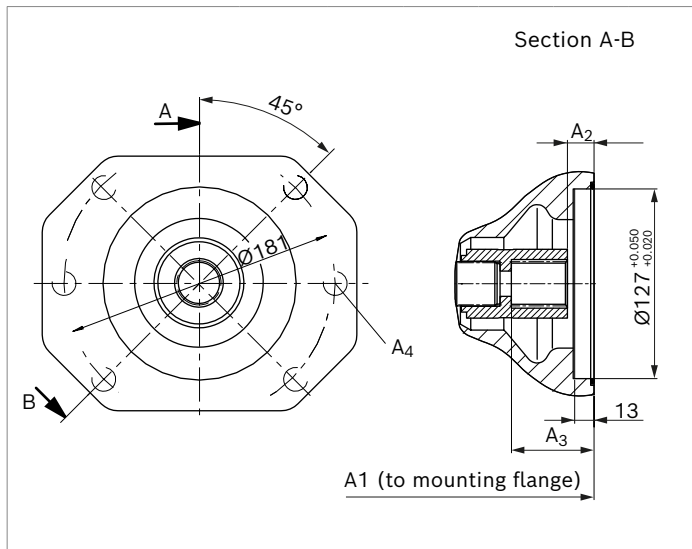

K07 (SAE J744 32-4 (C))	NG	A1	A2 <sup>4)</sup>	A3 <sup>4)</sup>	A4 <sup>3)</sup>
	85	301.5	22	60	M16 × 2; 24 deep
	100	301.5	22	60	M16 × 2; 24 deep

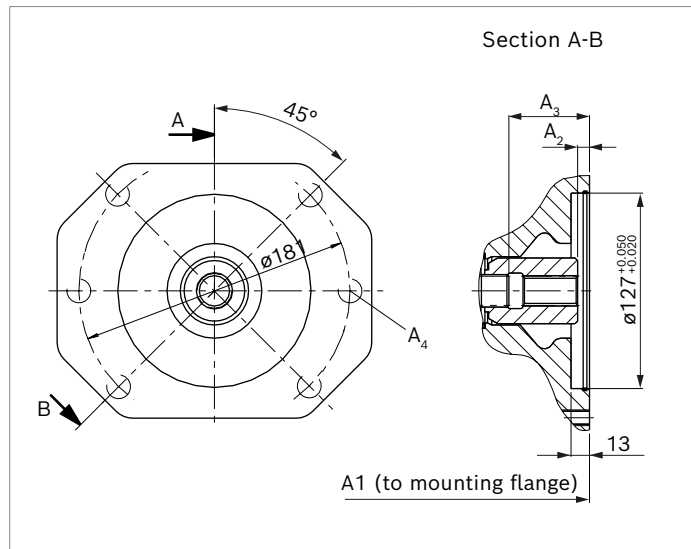

K24 (SAE J744 38-4 (C-C))	NG	A1	A2 <sup>4)</sup>	A3 <sup>4)</sup>	A4 <sup>3)</sup>
	85	302	12.8	67.2	M16 × 2; 24 deep
	100	302	12.8	67.2	M16 × 2; 24 deep

1) According to ANSI B92.1a, 30° pressure angle, flat root, side fit, tolerance class 5  
 2) Mounting holes pattern viewed on through drive with control at top

3) Thread according to DIN 13.  
 4) Minimum dimensions

## Overview of mounting options

Through drive			Mounting options – 2nd pump			
Flange ISO 3019-1	Hub for splined shaft	Code	A10V(S)O/5x NG (shaft)	A10VO/31 NG (shaft)	A1VO/10 NG (shaft)	External gear pump
82-2 (A)	5/8 in	K01	10 (U), 18 (U)	18 (U)	18 (S2)	AZPF
	3/4 in	K52	10 (S), 18 (S, R)	18 (S, R)	18 (S3)	
101-2 (B)	7/8 in	K68	28 (S, R) 45 (U, W) <sup>1)</sup>	28 (S, R) 45 (U, W)	35 (S4)	AZPN/AZPG
	1 in	K04	45 (S, R) 60, 63 (U, W) <sup>2)</sup> 72 (U, W) <sup>2)</sup>	45 (S, R)	35 (S5)	
127-4 (C)	1 1/4 in	K15	60, 63 (S, R) 72 (S, R)	–	–	–
	1 1/2 in	K16	85 (S) 100 (S)	–	–	–
127-2 (C)	1 1/4 in	K07	85 (U) 100 (U)	71 (S, R)	–	PGH5
	1 1/2 in	K24	85 (S) 100 (S)	–	–	–

1) Not for NG28 with K68

2) Not for NG45 with K04

## Combination pumps A10VO + A10VO

By using combination pumps, it is possible to have independent circuits without the need for splitter gearboxes. When ordering combination pumps, the type designations of pump 1 and 2 pumps must be linked by a "+".

### Order example:

**A10VO85DRS/53R-VSC12K04+**

**A10VO45DRF/53R-VSC11N00**

A tandem pump, with two pumps of equal size, is permissible without additional supports, assuming that the dynamic mass acceleration does not exceed maximum 10 g (= 98.1 m/s<sup>2</sup>).

For combination pumps consisting of more than two pumps, a calculation of the mounting flange regarding the permissible mass torque is required (please contact us). Through drives are plugged with a **non-pressure-resistant** cover. This means the units must be sealed with a pressure-resistant cover before commissioning. Through drives can also be ordered with a pressure-resistant cover, please specify in plain text.

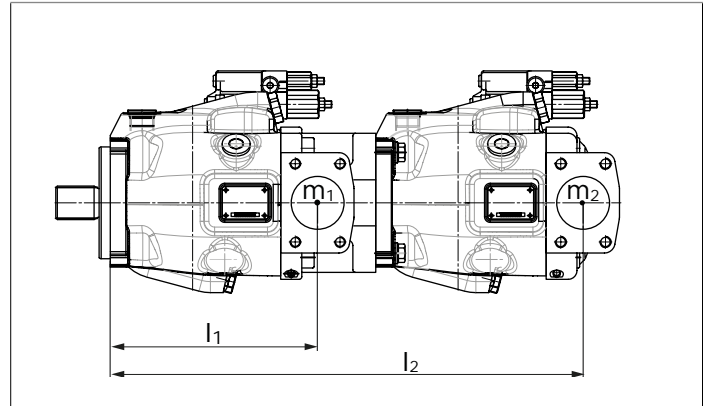

$m_1, m_2, m_3$	Weight of pump	[kg]
$l_1, l_2, l_3$	Distance from center of gravity	[mm]
$M_m = (m_1 \times l_1 + m_2 \times l_2 + m_3 \times l_3) \times \frac{1}{102}$		[Nm]

### Notice

Through drives with installed hub are supplied with a spacer.

The spacer must be removed before the 2nd pump is installed and before commissioning. For further information, see instruction manual 92703-01-B

### Permissible moments of inertia

NG			10	18	28	45	60/63	72	85	100
static	$M_m$	Nm	-	500	890	900	1370	1370	3080	3080
			dynamic at 10 g (98.1 m/s <sup>2</sup> )	-	50	89	90	137	137	308
Weight with through-drive plate		$m$	kg	-	13	18	24	28	45	45
Weight without through-drive plate (e.g. 2nd pump)				8	11.5	15	18	22	36	36
Distance, center of gravity <b>without</b> through drive		$l_1$	mm	-	78	85	96	105	122	122
Distance, center of gravity <b>with</b> through drive		$l_1$	mm	-	87	99	115	127	150	150

## Connector for solenoids

### DEUTSCH DT04-2P

Molded, 2-pin, without bidirectional suppressor diode  
The installed mating connector has the following  
Type of protection:

- ▶ IP67 (DIN/EN 60529) and
- ▶ IP69K (DIN 40050-9)

#### ▼ Switching symbol

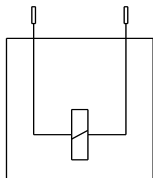

#### ▼ Mating connector DEUTSCH DT06-2S-EP04

Consisting of	DT designation
1 housing	DT06-2S-EP04
1 wedge	W2S
2 sockets	0462-201-16141

The mating connector is not included in the scope of delivery.

This can be supplied by Bosch Rexroth on request (material number R902601804).

#### Notice

If necessary, you can change the position of the connector by turning the solenoid body.  
The procedure is defined in the instruction manual.

## Control electronics

Control	Electronics function	Electronics		Data sheet
Electric pressure control	Controlled power outlet	RA	analog	95230
		RC4-5/30	digital	95205

## Installation instructions

### General

The axial piston unit must be filled with hydraulic fluid and air bled during commissioning and operation. This must also be observed following a longer standstill as the axial piston unit may empty via the hydraulic lines.

Particularly with the "drive shaft up/down" installation position, filling and air bleeding must be carried out completely as there is, for example, a danger of dry running. The leakage in the pump housing must be discharged to the reservoir via the highest available tank port (**L**, **L<sub>1</sub><sup>2)</sup>**, **L<sub>2</sub><sup>3)</sup>**). If a shared drain line is used for several units, make sure that the respective case pressure in each unit is not exceeded. The shared drain line must be dimensioned to ensure that the maximum permissible case pressure of all connected units is not exceeded in any operating condition, particularly at cold start. If this is not possible, separate drain line must be laid, if necessary.

To achieve favorable noise values, decouple all connecting lines using elastic elements and avoid above-reservoir installation.

In all operating conditions, the suction lines and the drain lines must flow into the reservoir below the minimum fluid level. The permissible suction height  $h_s$  results from the total pressure loss. However, it must not be higher than  $h_{s\ max} = 800\text{ mm}$ . The minimum suction pressure at port **S** must not fall below 0.8 bar absolute during operation and during cold start.

For the reservoir design, ensure that there is an adequate distance between the suction line and the drain line. This minimizes oil turbulence and carries out degassing, which prevents the heated hydraulic fluid from being sucked directly back in again.

### Notice

In certain installation positions, an influence on the adjustment or control can be expected. Gravity, dead weight and case pressure can cause minor characteristic shifts and changes in actuating time.

For key, see page 71.

- 1) Because complete air bleeding and filling are not possible in this position, the pump should be air bled and filled in a horizontal position before installation.
- 2) For NG10 and NG28 series 52, **L<sub>1</sub>** is opposite, **L** must then be connected if necessary.
- 3) Only series 53

### Installation position

See the following examples **1** to **12**.

Further installation positions are available upon request.  
 Recommended installation position: **1** and **3**

### Below-reservoir installation (standard)

Below-reservoir installation means that the axial piston unit is installed outside of the reservoir below the minimum fluid level.

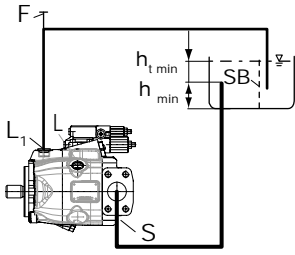
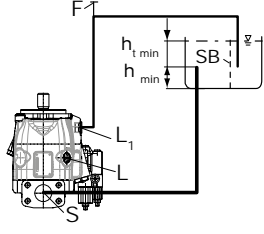
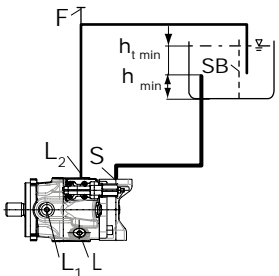
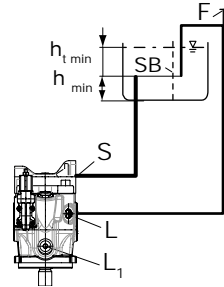
Installation position	Air bleed	Filling
1 <sup>2)</sup> 	<b>F</b>	<b>S + L or L<sub>1</sub></b>
2 <sup>1)</sup> 	<b>F</b>	<b>S + L<sub>1</sub></b>
3 <sup>3)</sup> 	<b>F</b>	<b>S + L or L<sub>1</sub></b>
4 <sup>1)</sup> 	<b>F</b>	<b>S + L or L<sub>1</sub></b>

**Above-reservoir installation**

Above-reservoir installation means that the axial piston unit is installed above the minimum fluid level of the reservoir. To prevent the axial piston unit from draining in position 6, the height difference  $h_{ES\ min}$  must be at least 25 mm. Observe the maximum permissible suction height  $h_{S\ max} = 800\ mm$ .

A check valve in the case drain line is only permissible in individual cases. Consult us for approval.

For key, see page 71.

Installation position	Air bleed	Filling
<p>5<sup>2)</sup></p>	F	L <sub>1</sub> or L
<p>6<sup>1)2)</sup></p>	F	L <sub>1</sub>
<p>7<sup>3)</sup></p>	F	L <sub>2</sub>
<p>8<sup>1)</sup></p>	F	S or L

- 1) Because complete air bleeding and filling are not possible in this position, the pump should be air bled and filled in a horizontal position before installation.
- 2) For NG10 and NG28 series 52, L<sub>1</sub> is opposite, L must then be connected if necessary.
- 3) Only series 53

### Inside-reservoir installation

Inside-reservoir installation is when the axial piston unit is installed in the reservoir below the minimum fluid level. The axial piston unit is completely below the hydraulic fluid. If the minimum fluid level is equal to or below the upper edge of the pump, see chapter "Above-reservoir installation". Axial piston units with electrical components (e.g. electric control, sensors) may not be installed in a reservoir below the fluid level.

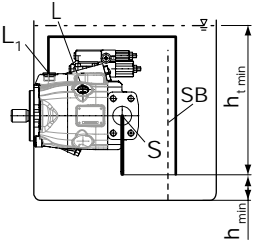
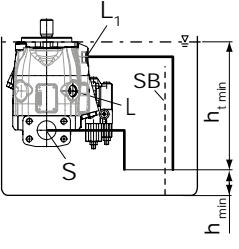
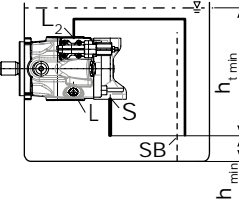
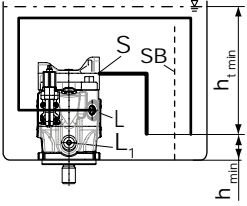
Installation position	Air bleed	Filling
<p>9<sup>2)</sup></p> 	Via the highest available port <b>L</b>	Automatically via the open port <b>L</b> or <b>L<sub>1</sub></b> due to the position under the hydraulic fluid level
<p>10<sup>1)</sup></p> 	Via the highest available port <b>L<sub>1</sub></b>	Automatically via the open port <b>L</b> , <b>L<sub>1</sub></b> or <b>S</b> due to the position under the hydraulic fluid level
<p>11<sup>3)</sup></p> 		
<p>12<sup>1)</sup></p> 	Via the highest available port <b>L</b>	Automatically via the open port <b>L</b> , <b>L<sub>1</sub></b> or <b>S</b> due to the position under the hydraulic fluid level

Key	
<b>F</b>	Filling / Air bleeding
<b>S</b>	Suction port
<b>L; L<sub>1</sub>; L<sub>2</sub></b>	Drain port
<b>SB</b>	Baffle (baffle plate)
$h_{t \min}$	Minimum required immersion depth (200 mm)
$h_{\min}$	Minimum required distance to reservoir bottom (100 mm)
$h_{ES \min}$	Minimum height required to prevent axial piston unit from draining (25 mm)
$h_{S \max}$	Maximum permissible suction height (800 mm)

### Notice

Port **F** is part of the external piping and must be provided on the customer side to make filling and air bleeding easier.

- 1) Because complete air bleeding and filling are not possible in this position, the pump should be air bled and filled in a horizontal position before installation.
- 2) For NG10 and NG28 series 52, **L<sub>1</sub>** is opposite, **L** must then be connected if necessary.
- 3) Only series 53

## Project planning notes

- ▶ The A10VO axial piston variable pump is designed to be used in open circuit.
- ▶ Project planning, installation and commissioning of the axial piston units requires the involvement of skilled personnel.
- ▶ Before using the axial piston unit, please read the corresponding instruction manual completely and thoroughly. If necessary, this can be requested from Bosch Rexroth.
- ▶ Before finalizing your design, request a binding installation drawing.
- ▶ The specified data and notes contained herein must be observed.
- ▶ Depending on the operating conditions of the axial piston unit (working pressure, fluid temperature), the characteristic curve may shift. The characteristic curve may also shift due to the dither frequency or control electronics.
- ▶ Preservation: Our axial piston units are supplied as standard with preservation protection for a maximum of 12 months. If longer preservation protection is required (maximum 24 months), please specify this in plain text when placing your order. The preservation periods apply under optimal storage conditions, details of which can be found in the data sheet 90312 or the instruction manual.
- ▶ Not all versions of the product are approved for use in safety functions according to ISO 13849. Please consult the proper contact at Bosch Rexroth if you require reliability parameters (e.g.  $MTTF_d$ ) for functional safety.
- ▶ Depending on the type of control used, electromagnetic effects can be produced when using solenoids. Applying a direct voltage signal (DC) to solenoids does not create electromagnetic interference (EMI) nor is the solenoid affected by EMI. Electromagnetic interference (EMI) potential exists when operating and controlling a solenoid with a modulated direct voltage signal (e.g. PWM signal) Appropriate testing and measures should be taken by the machine manufacturer to ensure other components or operators (e.g. with pacemaker) are not affected by this potential.
- ▶ Pressure controllers are not safeguards against pressure overload. Be sure to add a pressure relief valve to the hydraulic system.
- ▶ For drives that are operated for a long period of time with constant rotational speed, the natural frequency of the hydraulic system can be stimulated by the excitation frequency of the pump (rotational speed frequency  $\times 9$ ). This can be prevented with suitably designed hydraulic lines.
- ▶ Please note the details regarding the tightening torques of port threads and other threaded joints in the instruction manual.
- ▶ Working ports:
  - The ports and fastening threads are designed for the specified maximum pressure. The machine or system manufacturer must ensure the connecting elements and lines correspond to the specified application conditions (pressure, flow, hydraulic fluid, temperature) with the necessary safety factors.
  - The service ports and function ports are only intended to accommodate hydraulic lines.

## Safety instructions

- ▶ During and shortly after operation, there is a risk of getting burnt on the axial piston unit and especially on the solenoids. Take the appropriate safety measures (e.g. by wearing protective clothing).
- ▶ Moving parts in control equipment (e.g. valve spools) can, under certain circumstances, get stuck in position as a result of contamination (e.g. contaminated hydraulic fluid, abrasion, or residual dirt from components). As a result, the hydraulic fluid flow and the build-up of torque in the axial piston unit can no longer respond correctly to the operator's specifications. Even the use of various filter elements (external or internal flow filtration) will not rule out a fault but merely reduce the risk.

The machine/system manufacturer should test whether additional measures are required on the machine for the relevant application in order to bring the driven consumer into a safe position (e.g. safe stop) and make sure any measures are properly implemented.





