



PRANCE HYDRAULIC

# Axial Piston Variable Double Pump A20VO

RE 93 100/05.06 1/16  
Replace: 07.03

## Technical data sheet

Series 1	
Sizes	Nominal pressure/ Peak pressure
60	250/315 bar
95...520	350/400 bar
for open circuits	

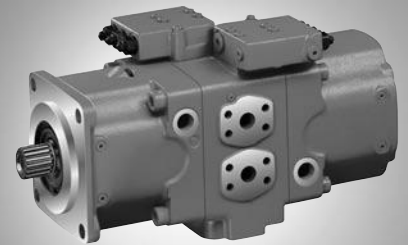

## Contents

Ordering Code / Standard Program	2
Technical Data	3
Through Drive	3
Control Devices	4
Unit Dimensions, Size 60	6
Unit Dimensions, Size 95	8
Unit Dimensions, Size 190 (with impeller)	10
Unit Dimensions, Size 260 (with impeller)	12
Unit Dimensions, Size 520	14
General Notes	16

## Features

- Variable pump with two axial piston rotary groups in swash-plate design for use in open circuit hydrostatic drives
- For use in mobile and stationary applications
- The pump consists of proven components from the A11VO (RE 92500), A10VO/53 (RE 92703) or A4VSO (RE 92050) variable pumps
- The pump operates under self-priming condition, with tank pressurisation or with charge pump (sizes 190...260)
- A wide variety of controls are available
- Setting of the constant power control is possible via external adjustments, even when the unit is operating (only with power control).
- The pump is available with a through drive to mount a gear pump or a second axial piston pump
- Output flow is proportional to drive speed and pump displacement and is steplessly variable between maximum and zero displacement

# Ordering Code / Standard Program

<b>A20V</b>		<b>O</b>			<b>/</b>	<b>10</b>		<b>-</b>					
01	02	03	04	05		06	07		08	09	10	11	12

## Axial piston unit

01	Swashplate design, variable (Back to back - design)											<b>A20V</b>
----	---	--	--	--	--	--	--	--	--	--	--	-------------

## Charge pump (impeller)

	60	95	190	260	520		
02	without charge pump (no code)	●	●	-	-	●	
	with charge pump	-	-	●	●	-	L

## Operation

03	Double pump, open circuit											<b>O</b>
----	---------------------------	--	--	--	--	--	--	--	--	--	--	----------

## Size

04	≈ Displacement $V_{g\ max}$ in $cm^3$ (per rotary group)	<b>60</b>	<b>95</b>	<b>190</b>	<b>260</b>	<b>520</b>
----	--	-----------	-----------	------------	------------	------------

## Control devices

	60	95	190	260	520		
05	see RE 92703 (A10VO/53)	●	-	-	-	-	
	see RE 92500 (A11VO)	-	●	●	●	-	
	see RE 92050 (A4VSO) and RE 92060, RE 92064, RE 92076	-	-	-	-	●	

## Series

06	Series 1, Index 0											<b>10</b>
----	-------------------	--	--	--	--	--	--	--	--	--	--	-----------

## Direction of rotation

07	viewed on shaft end	clockwise		<b>R</b>
		counter-clockwise		<b>L</b>

## Seals

	60	95	190	260	520		
08	NBR (nitril-caoutchouc), shaft seal ring in FKM (fluor-caoutchouc)	●	●	●	●	-	N
	FKM (fluor-caoutchouc)	-	-	-	-	●	V

## Shaft end

	60	95	190	260	520		
10	Splined shaft DIN 5480	-	●	●	●	●	Z
	Splined shaft, ANSI B92.1a-1976	●	●	-	-	-	S
		-	-	●	●	-	T
	Parallel keyed shaft, DIN 6885	-	-	-	-	●	P

## Mounting flange

	60	95	190	260	520		
09	SAE J744 - 4-hole	●	●	●	●	-	D
	To fit flywheel housing (conform to SAE J617) of internal combustion engine (details on request)	-	●	●	-	-	G
	ISO 3019-2 - 8-hole	-	-	-	-	●	H

## Service line ports

	60	95	190	260	520		
11	Two service line ports and one scution port at site, opposite (fastening thread metric)	●	●	●	●	-	24
	At the site two service line ports each, opposite and one suction port displaced by 90° (fastening thread metric)	-	-	-	-	●	26

## Boost pump and through drive<sup>1)</sup>

	60	95	190	260	520				
12	without boost pump, without through drive	●	●	●	●	-	N00		
	without boost pump, with through drive								
	Flange SAE J744								
	Splined shaft hub								
	82-2 (A)	5/8 in	9T 16/32DP (A)	○	○	○	○	-	K01
	127-2 (C)	1 1/4in	14T 12/24DP (C)	-	-	-	-	●	K07
	with through drive shaft, without hub, without intermediate flange, closed by a cover	-	-	-	-	-	●		K99

● = available    ○ = available on request    - = not available

<sup>1)</sup> Please contact us



# Technical Data

**Table of values** (theoretical values, without efficiencies  $\eta_{mh}$  and  $\eta_v$ ; values rounded)

Size	<i>without charge pump</i>		60	95	190	260	520
	<i>with charge pump</i>						
Displacement	$V_{g \max}$	cm <sup>3</sup>	60	93,8	192,7	260	520
(per rotary group)	$V_{g \min}$	cm <sup>3</sup>	0	0	0	0	0
Speed							
maximal <sup>1)</sup> at $V_{g \max}$	$n_{\max}$	min <sup>-1</sup>	2700	2350	2500 <sup>2)</sup>	2300 <sup>2)</sup>	1450
Speed max. <sup>3)</sup> at $V_g \leq V_{g \max}$	$n_{\max}$	min <sup>-1</sup>	3200	2780	2500	2300	1720
Flow							
at $n_{\max}$ and $V_{g \max}$	$q_{v \max}$	L/min	2x162	2x220	2x482	2x598	2x754
Power at $q_{v \max}$ and $\Delta p = 350$ bar	$P_{\max}$	kW	135 <sup>4)</sup>	257	562	698	880
Torque at $V_{g \max}$							
at long-term ( $\Delta p = 350$ bar)	$T_{\max}$	Nm	477 <sup>4)</sup>	1045	2147	2897	5793
max. perm., short term ( $\Delta p = 400$ bar)	$T_{\max}$	Nm	602 <sup>4)</sup>	1194	2454	3310	6621
Moment of inertia (of the rotating parts)	J	kgm <sup>2</sup>	0,0113	0,0346	0,0604	0,0912	0,696
Mass approx.	m	kg	44				640

<sup>1)</sup> The values are quoted for an absolute pressure ( $p_{abs}$ ) of 1 bar at suction port S and mineral operating fluid.

<sup>2)</sup> The values are quoted for an absolute pressure ( $p_{abs}$ ) of at least 0.8 bar at suction port S and mineral operating fluid.

<sup>3)</sup> The values are quoted for  $V_g < V_{g \max}$  or increase of the input pressure  $p_{abs}$  at suction port S.

<sup>4)</sup>  $\Delta p = 250$  bar (long-term operation) or rather 315 bar (short term).

## Through Drive

Please contact us.



# Control Devices

## Example circuit diagram Size 60: DFR

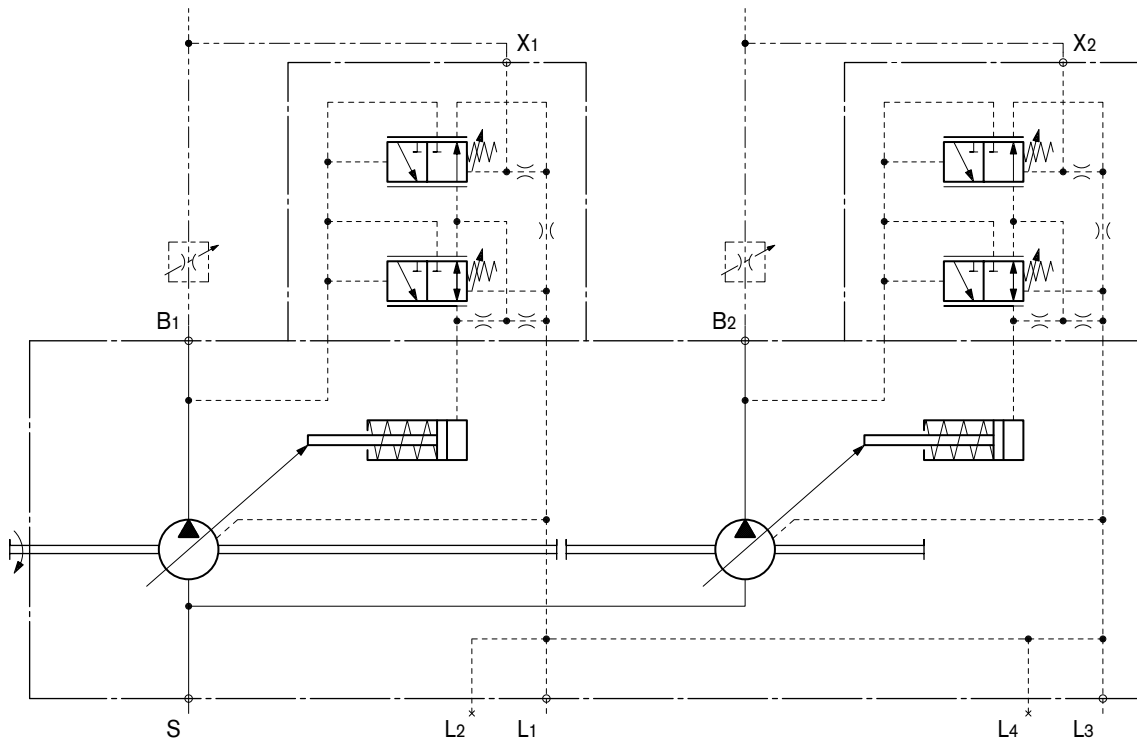

## Example circuit diagram Size 95...260: HD1D

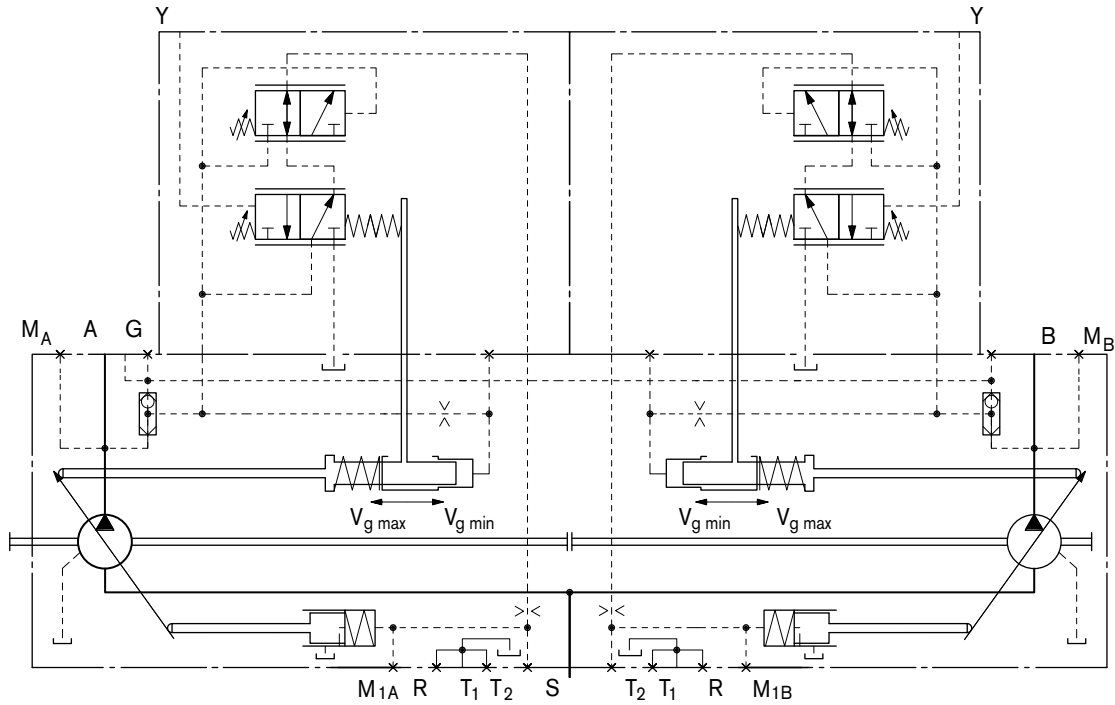



# Control Devices

## Example circuit diagram Size 520: LR2DN

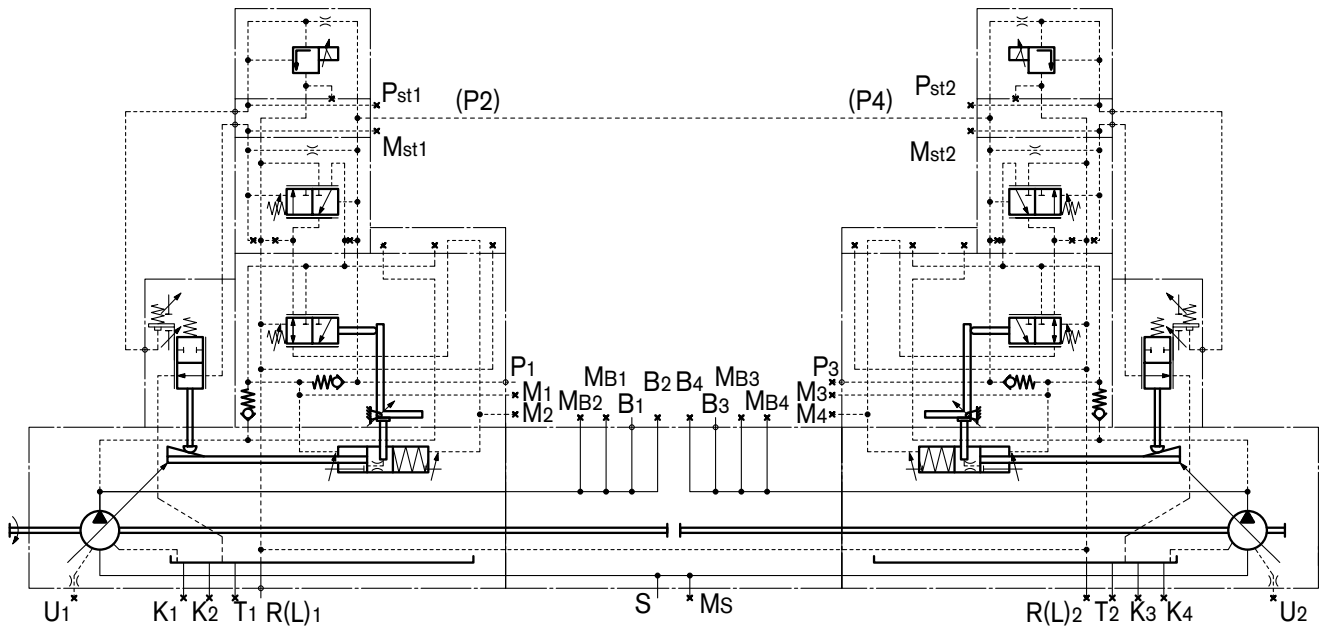

Further technical datas as soon as control devices see

for size 60 \_\_\_\_\_ RE 95703 (A10VO/53)

for sizes 95 ... 260 \_\_\_\_\_ RE 92500 (A11VO)

for size 520 \_\_\_\_\_ RE 92050 (A4VSO), RE 92060, RE 92064, RE 92076



# Unit Dimensions, Size 60

For controller selection see RE 92703 (A10VO/53)

Before finalizing your design, please request a approved installation drawing.  
Dimensions in mm

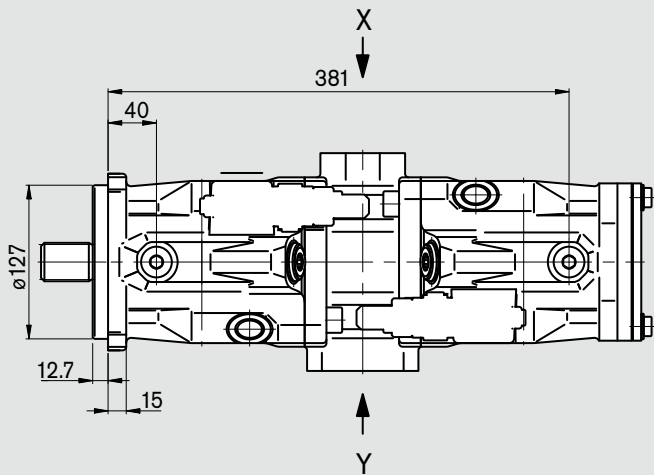
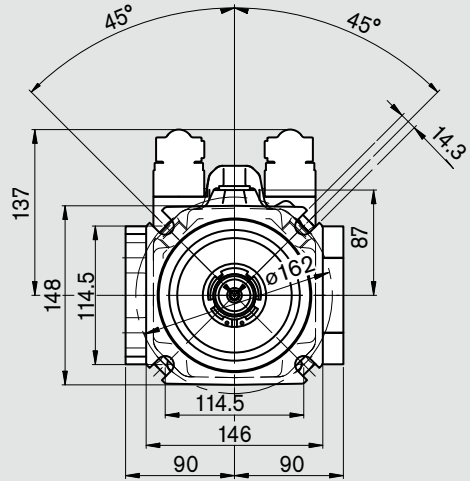
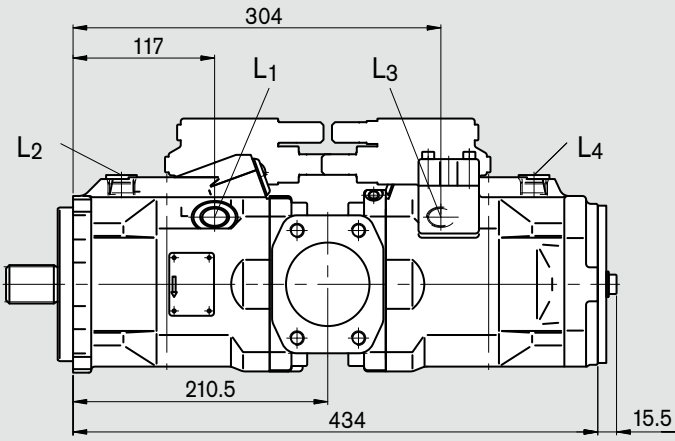

View Z

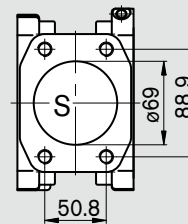

View Y

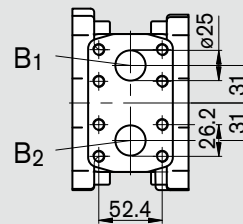



PRANCE HYDRAULIC

# Unit Dimensions, Size 60

Before finalizing your design, please request a approved installation drawing.  
Dimensions in mm

## Shaft end

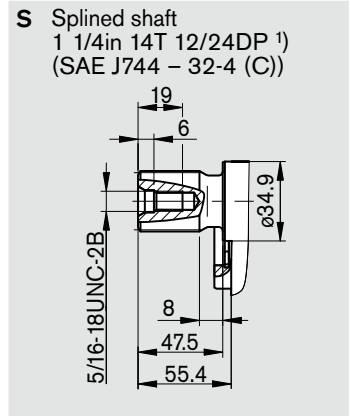

## Ports

B <sub>1</sub> , B <sub>2</sub>	Service ports (High pressure series)	SAE J518	1 in	
	Fastening thread	DIN 13	M10x1,5; 17 deep <sup>2)</sup>	
S	Suction port	SAE J518	2 1/2 in	
	Fastening thread	DIN 13	M12x1,75; 20 deep <sup>2)</sup>	
L <sub>1,2,3,4</sub>	Case drain	DIN 3852	7/8-14UNF-2B	240 Nm <sup>2)</sup>

<sup>1)</sup> ANSI B92.1a-1976, pressure angle 30°, flat rood, side fit, tolerance class 5

<sup>2)</sup> please observe the general notes for the max. tightening torques on page 16



# Unit Dimensions, Size 95

For controller selection see RE92500 (A11VO)

Before finalizing your design, please request a approved installation drawing.  
Dimensions in mm

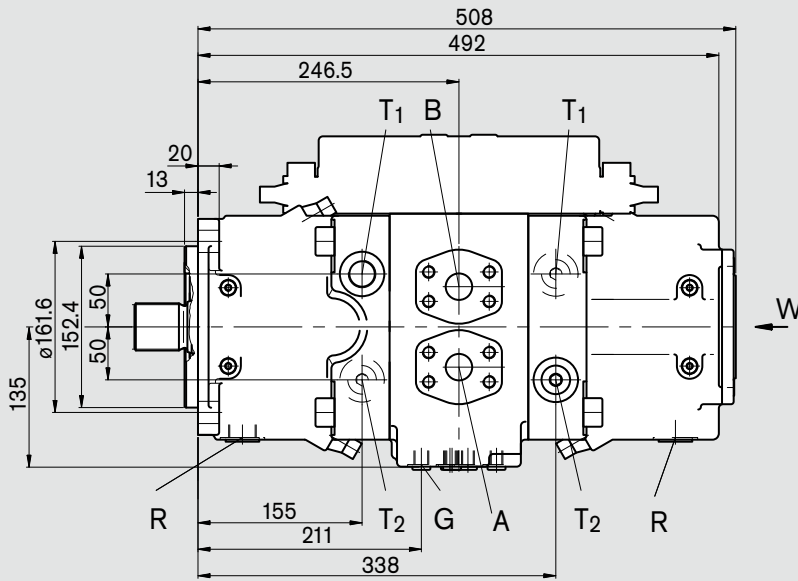

View W

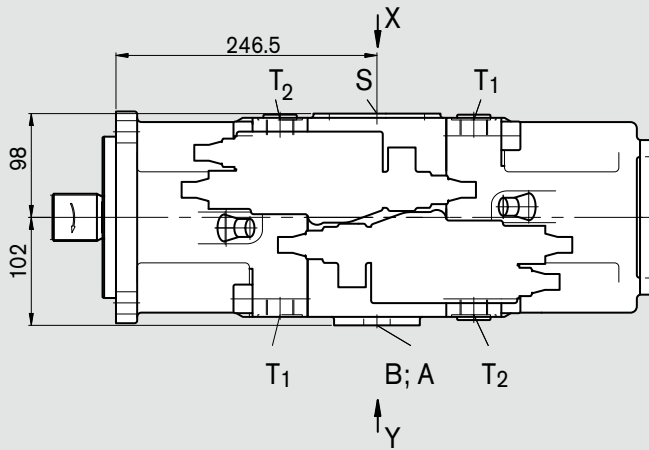
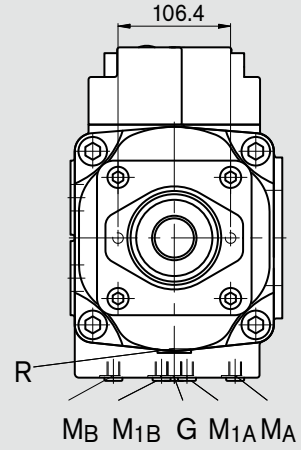

View Z

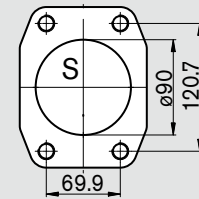

View Y

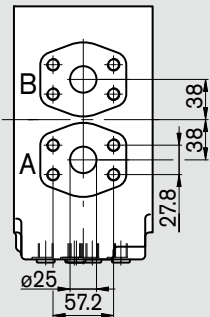



# Unit Dimensions, Size 95

Before finalizing your design, please request a approved installation drawing.  
Dimensions in mm

## Shaft ends

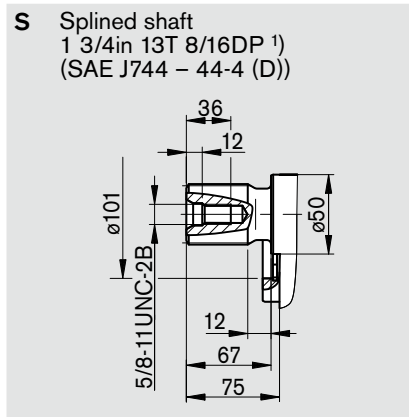
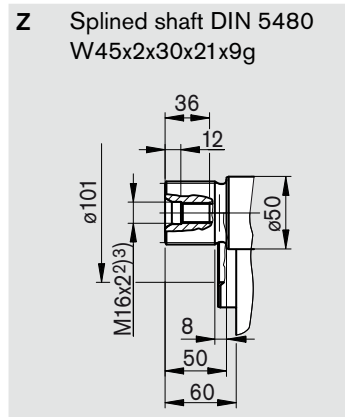

## Ports

A, B	Service ports (High pressure series)	SAE J518	1 in	
	Fastening threads	DIN 13	M12x1,75; 17 deep <sup>3)</sup>	
S	Suction port (standard series)	SAE J518	3 1/2 in	
	Fastening threads	DIN 13	M16x2; 24 deep <sup>3)</sup>	
T <sub>1</sub> , T <sub>2</sub>	Case drain	DIN3852	M26x1,5; 14 deep	230 Nm <sup>3)</sup>
M <sub>A</sub> , M <sub>B</sub>	Gauge point positioning chamber	DIN3852	M12x1,5; 12 deep	50 Nm <sup>3)</sup>
M <sub>A1</sub> , M <sub>B1</sub>	Gauge point for service port	DIN3852	M12x1,5; 12 deep	50 Nm <sup>3)</sup>
R	Air bleed, drain port	DIN3852	M26x1,5; 14 deep	230 Nm <sup>3)</sup>
G	Control pressure port (controller) <sup>4)</sup>	DIN3852	M14x1,5; 12 deep	80 Nm <sup>3)</sup>

<sup>1)</sup> ANSI B92.1a-1976, pressure angle 30°, flat rood, side fit, tolerance class 5

<sup>2)</sup> Center bore according to DIN 332 (thread according to DIN13)

<sup>3)</sup> please observe the general notes for the max. tightening torques on page 16

<sup>4)</sup> At design with stroke limiter (H..., U2), HD and EP with fitting GE10-PLM (in other case is port G plugged)



# Unit Dimensions, Size 190 (with impeller)

For controller selection see RE92500 (A11VO)

Before finalizing your design, please request a approved installation drawing.  
Dimensions in mm

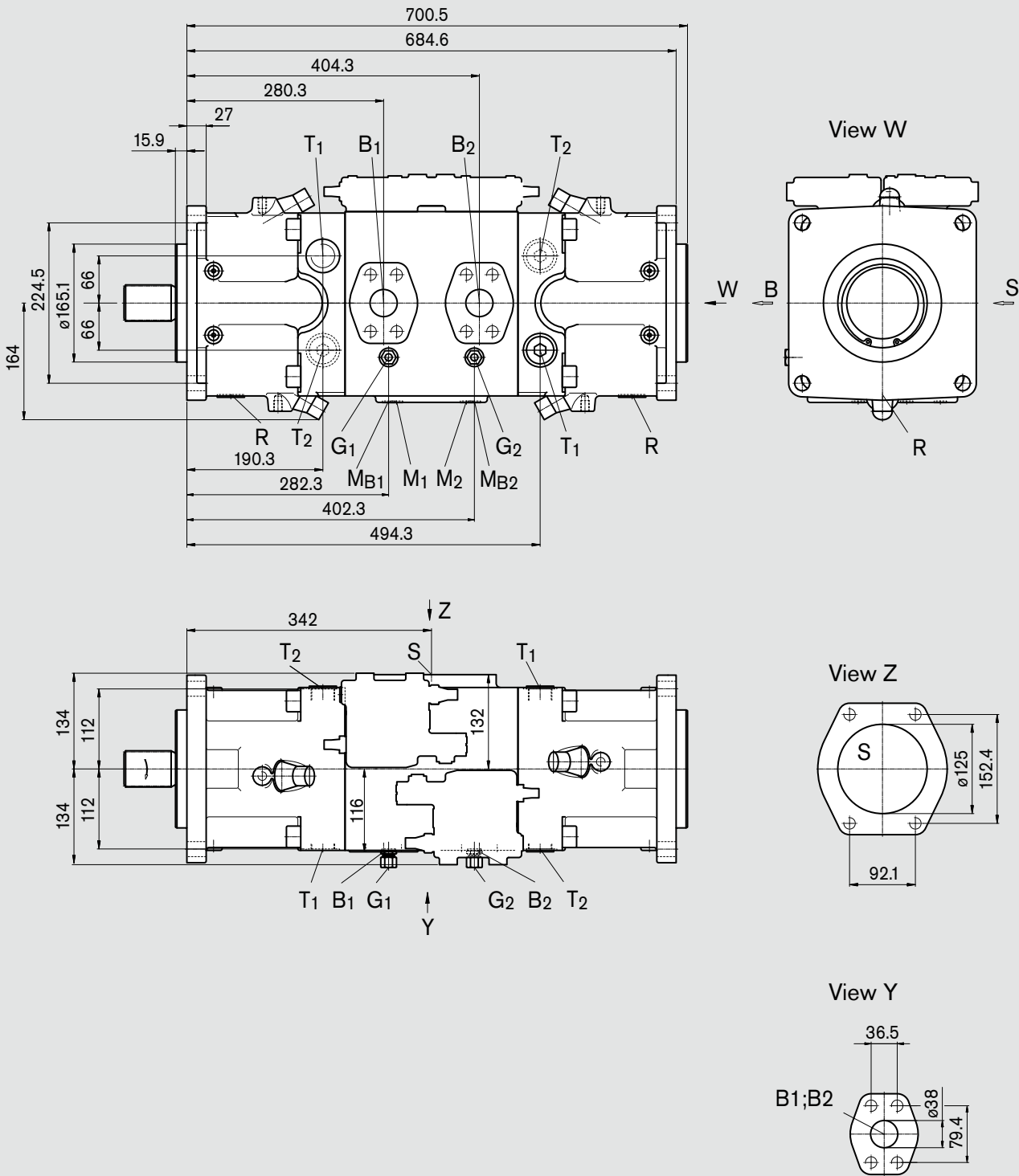



# Unit Dimensions, Size 190 (with impeller)

Before finalizing your design, please request a approved installation drawing. Dimensions in mm

## Shaft ends

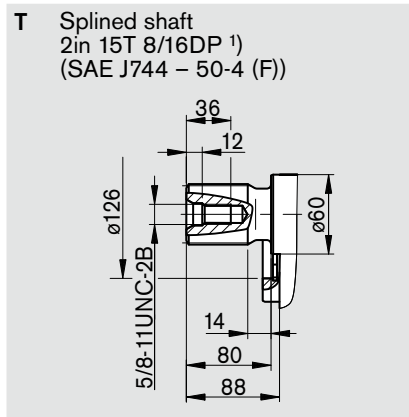
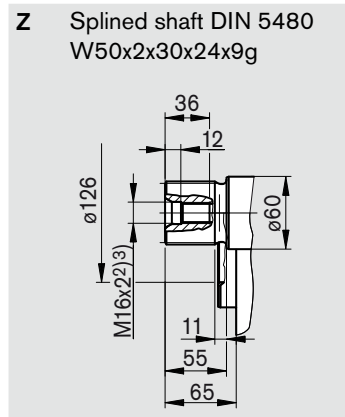

## Connections

B <sub>1</sub> , B <sub>2</sub>	Service ports (High pressure series)	SAE J518	1 1/2 in	
	Fastening threads	DIN 13	M16x2; 21 deep	
S	Suction port (standard series)	SAE J518	5 in	
	Fastening threads	DIN 13	M16x2; 23 deep	
T <sub>1</sub> , T <sub>2</sub>	Case drain	DIN3852	M33x2; 18 deep	540 Nm <sup>4)</sup>
M <sub>1</sub> , M <sub>2</sub>	Gauge point positioning chamber	DIN3852	M12x1,5; 12 deep	50 Nm <sup>4)</sup>
M <sub>B1</sub> , M <sub>B2</sub>	Gauge point for service port	DIN3852	M12x1,5; 12 deep	50 Nm <sup>4)</sup>
R	Air bleed, drain port	DIN3852	M33x2; 16 deep	540 Nm <sup>4)</sup>
G <sub>1</sub> , G <sub>2</sub>	Control pressure port (controller) <sup>4)</sup>	DIN3852	M14x1,5; 12 deep	80 Nm <sup>4)</sup>

<sup>1)</sup> ANSI B92.1a-1976, pressure angle 30°, flat rood, side fit, tolerance class 5

<sup>2)</sup> Center bore according to DIN 332 (thread according to DIN13)

<sup>3)</sup> please observe the general notes for the max. tightening torques on page 16

<sup>4)</sup> At design with stroke limiter (H..., U2), HD and EP with fitting GE10-PLM (in other case is port G plugged)



# Unit Dimensions, Size 260 (with impeller)

For controller selection see RE92500 (A11VO)

Before finalizing your design, please request a approved installation drawing. Dimensions in mm

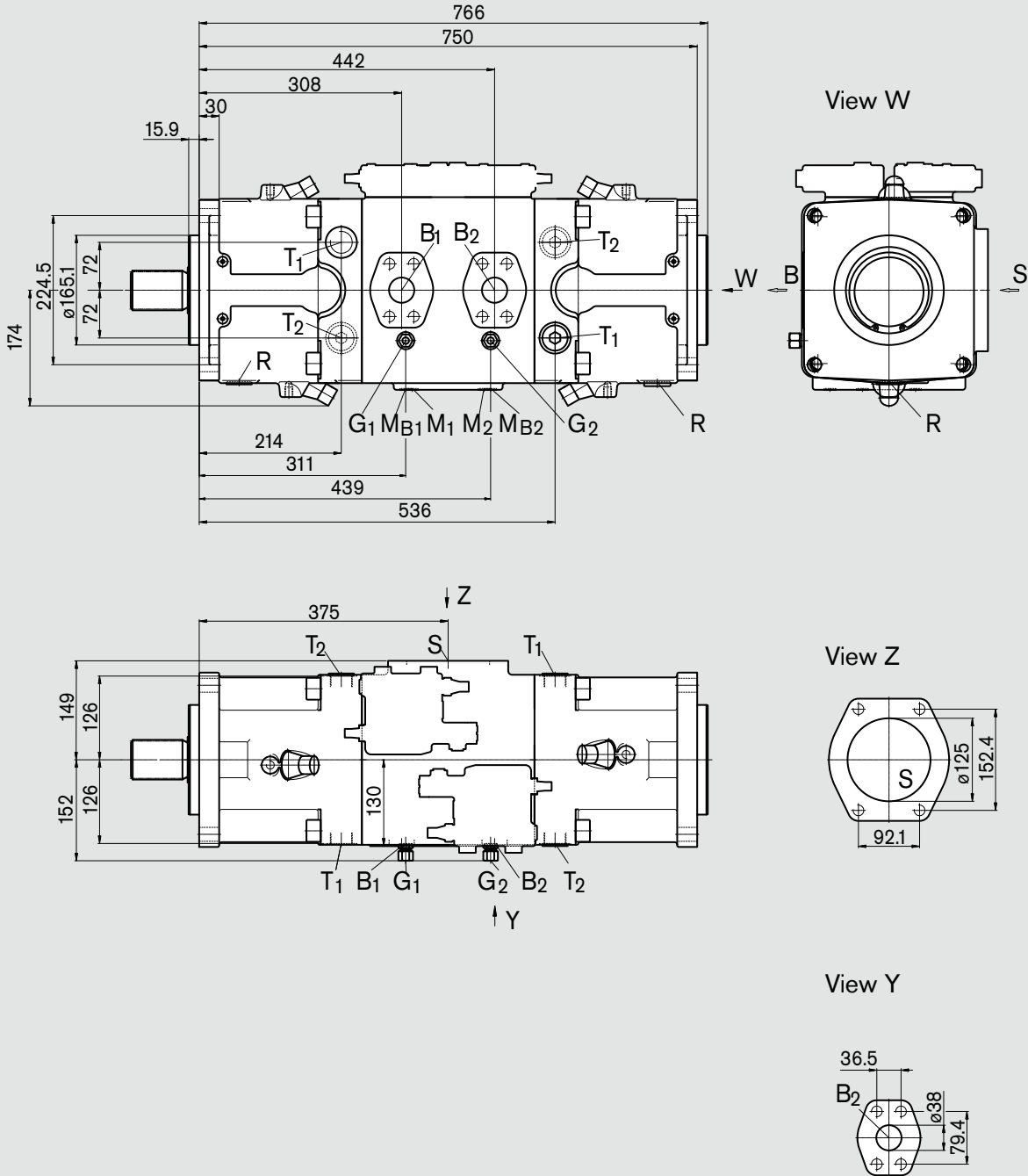



# Unit Dimensions, Size 260 (with impeller)

Before finalizing your design, please request a approved installation drawing. Dimensions in mm

## Shaft ends

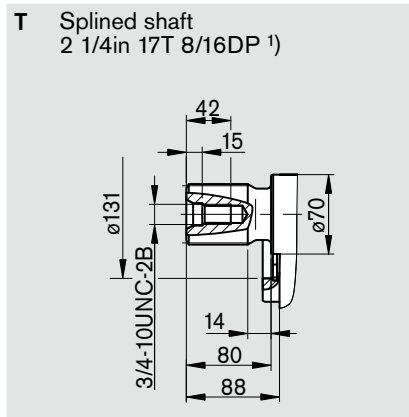
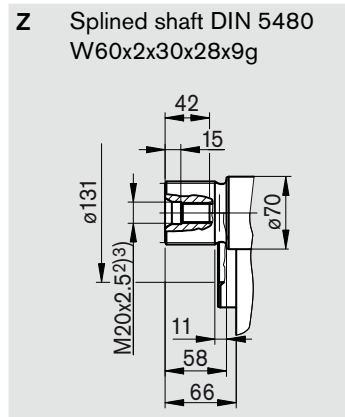

## Connections

B <sub>1</sub> , B <sub>2</sub>	Service ports (High pressure series)	SAE J518	1 1/2 in	
	Fastening threads	DIN 13	M16x2; 21 deep <sup>3)</sup>	
S	Suction port (standard series)	SAE J518	5 in	
	Fastening threads	DIN 13	M16x2; 23 deep <sup>3)</sup>	
T <sub>1</sub> , T <sub>2</sub>	Case drain	DIN3852	M33x2; 18 deep	540 Nm <sup>3)</sup>
M <sub>1</sub> , M <sub>2</sub>	Gauge point positioning chamber	DIN3852	M12x1,5; 12 deep	50 Nm <sup>3)</sup>
M <sub>B1</sub> , M <sub>B2</sub>	Gauge point for service port	DIN3852	M12x1,5; 12 deep	50 Nm <sup>3)</sup>
R	Air bleed, drain port	DIN3852	M33x2; 16 deep	540 Nm <sup>3)</sup>
G <sub>1</sub> , G <sub>2</sub>	Control pressure port (controller) <sup>3)</sup>	DIN3852	M14x1,5; 12 deep	80 Nm <sup>3)</sup>

<sup>1)</sup> ANSI B92.1a-1976, pressure angle 30°, flat rood, side fit, tolerance class 5

<sup>2)</sup> Center bore according to DIN 332 (thread according to DIN13)

<sup>3)</sup> please observe the general notes for the max. tightening torques on page 16

<sup>4)</sup> At design with stroke limiter (H..., U2), HD and EP with fitting GE10-PLM (in other case is port G plugged)





# Unit Dimensions, Size 520

Before finalizing your design, please request a approved installation drawing. Dimensions in mm

## Shaft ends

**Z** Splined shaft DIN 5480  
W80x3x30x25x9g

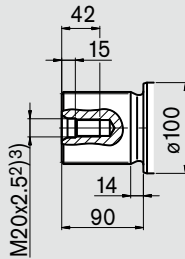

**P** Parallel keyed shaft  
DIN 6885

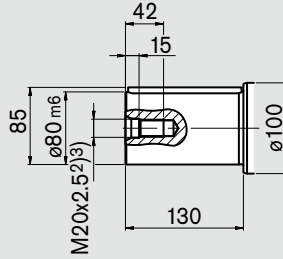

## Connections

B <sub>1</sub> - B <sub>4</sub>	Service line ports (High pressure series)	SAE J518	2 in	
	Fastening threads	DIN 13	M20x2,5; 24 deep <sup>3)</sup>	
S	Suction port (standard series)	SAE J518	5 in	
	Fastening threads	DIN 13	M16x2; 24 deep <sup>3)</sup>	
K <sub>1</sub> - K <sub>4</sub>	Flush ports		M48x2; 22 deep	960 Nm <sup>3)</sup>
M <sub>B1</sub> , M <sub>B4</sub>	Gauge point for operating pressure	DIN3852	M18x1,5; 12 deep	140 Nm <sup>3)</sup>
M <sub>S</sub>	Gauge point for suction port	DIN3852	M18x1,5; 12 deep	140 Nm <sup>3)</sup>
P <sub>st1</sub> , P <sub>st2</sub>	Pilot pressure port		M14x1,5; 12 deep	80 Nm <sup>3)</sup>
R (L)	Air bleed, drain port	DIN3852	M48x2; 22 deep	960 Nm <sup>3)</sup>
T	Case drain	DIN3852	M48x2; 22 deep	960 Nm <sup>3)</sup>
U	Flush port	DIN3852	M18x1,5; 12 deep	140 Nm <sup>3)</sup>

<sup>1)</sup> ANSI B92.1a-1976, pressure angle 30°, flat rood, side fit, tolerance class 5

<sup>2)</sup> Center bore according to DIN 332 (thread according to DIN13)

<sup>3)</sup> please observe the general notes for the max. tightening torques on page 16

<sup>4)</sup> At design with stroke limiter (H1) with fitting GE10-PLM (in other case is port G plugged)



# General Notes

- The pump A20VO is designed to be used in open circuits.
- Project planning, assembly and commissioning of the pump require the involvement of trained personnel.
- The working and functional ports are only designed to accommodate hydraulic piping.
- There is a danger of burns from the pump and especially the solenoids during and shortly after operation. Suitable safety precautions, e.g. protective clothing plan.
- The characteristic curve may shift depending on the operating status (operating pressure, fluid temperature) of the pump.
- Tightening torques:
  - The tightening torques specified in this data sheet are maximum values and may not be exceeded (maximum value for screw thread). Manufacturer specifications for the max. permissible tightening torques of the used fittings must be observed!
  - For DIN 13 fastening screws we recommend checking the tightening torque individually according to VDI 2230 Edition 2003.
- The data and information contained herein must be adhered to.

Bosch Rexroth AG  
Hydraulics  
Product Segment Axial Piston Units  
Elchingen Plant  
Glockeraustrasse 2  
89275 Elchingen, Germany  
Phone +49 (0) 73 08 82-0  
Facsimile +49 (0) 73 08 72 74  
info.brm-ak@boschrexroth.de  
www.boschrexroth.com/brm

Horb Plant  
An den Kelterwiesen 14  
72160 Horb, Germany  
Phone +49 (0) 74 51 92-0  
Facsimile +49 (0) 74 51 82 21

© This document, as well as the data, specifications and other information set forth in it, are the exclusive property of Bosch Rexroth AG. It may not be reproduced or given to third parties without its consent.

The data specified above only serve to describe the product. No statements concerning a certain condition or suitability for a certain application can be derived from our information. The information given does not release the user from the obligation of own judgment and verification. It must be remembered that our products are subject to a natural process of wear and aging.

Subject to change.