

HG SERIES GEAR PUMP
 HG SIGNLE PUMP

Product show and brief introduction

HG0 Size:8...20
 HG1 Size:25...63
 HG2 Size:80...160



Content:

MODEL CODE2
 SPECIFICATION3
 SPECIFICATION3
 SELECTION DIAGRAM4
 NOISE DIAGRM 4
 INSTALLATION DIMENSION..... 5
 PORT FLANGE DIMENSION.....11
 DOUBLE PUMP INSTRUCTION.....12
 DOUBLE PUMP MODEL CODE12
 DOUBLE PUMP INSTALLATION DIMENSION.....13
 DOUBLE PUMP PORT FLANGE DIMENSION21
 NOTICE21

HG 1 -40 -01 R -V P C

Pump

Internal gear pump	HG
--------------------	----

Code

Displacement 8...20	0
Displacement 25...63	1
Displacement 80...160	2

Size

Displacement (mL/r)										
8	10	13	16	20	25	32	40	50	63	
80	100	125	160							

Code

	01
--	----

Direction of rotating (viewed on shaft end)

CW	R
----	---

Seal type

Viton	V
-------	---

Shaft

Key shaft	P
Spling shaft	S

Mounting flange

SAE 2 holes	C
-------------	---

STRUCTURE

HG is fixed displacement and Intermittent compensation internal gear pump.

Front body(1), Middle Housing(2), rear cover(3), shaft bearing(4), Annular gear(5), Sliding bearing(6), Side plate(7),Locating rod(8), Crescent side plate(9), Crescent main plate(10) and plastic rod(11)

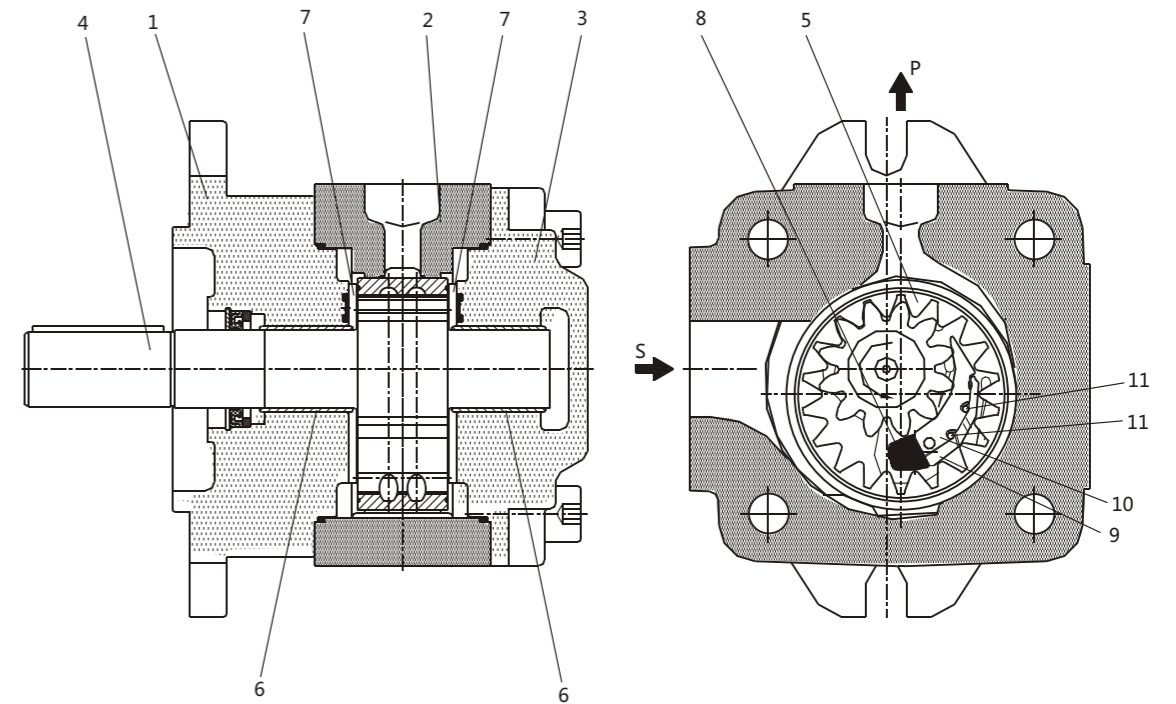

SPECIFICATION

MODEL	SIZE	DESP. mL/r	PRESSURE MPa		ROTATING SPEED r/min		WEIGHT kg
			RATED	MAX	MAX	MIN	
HG0	8	8.0	25	30	3000	600	4.4
	10	10.0	31.5	35	3000	600	4.6
	13	13.3	31.5	35	3000	600	4.9
	16	16.0	31.5	35	3000	600	5.2
	20	20.0	31.5	35	3000	600	5.6
HG1	25	25.3	31.5	35	3000	200	14.5
	32	32.7	31.5	35	3000	200	15
	40	40.1	31.5	35	3000	200	16
	50	50.7	31.5	35	3000	200	17
	63	63.7	31.5	35	3000	200	18.5
HG2	80	81.4	31.5	35	3000	200	43.5
	100	100.2	31.5	35	3000	200	45.5
	125	125.3	31.5	35	3000	200	48
	160	162.8	21	26	3000	200	52

INSTALLATION

Flow and pressure features: (Testing condition: $n=1450\text{r/min}$, $v=46\text{mm}^2/\text{s}$, $t=50^\circ\text{C}$)

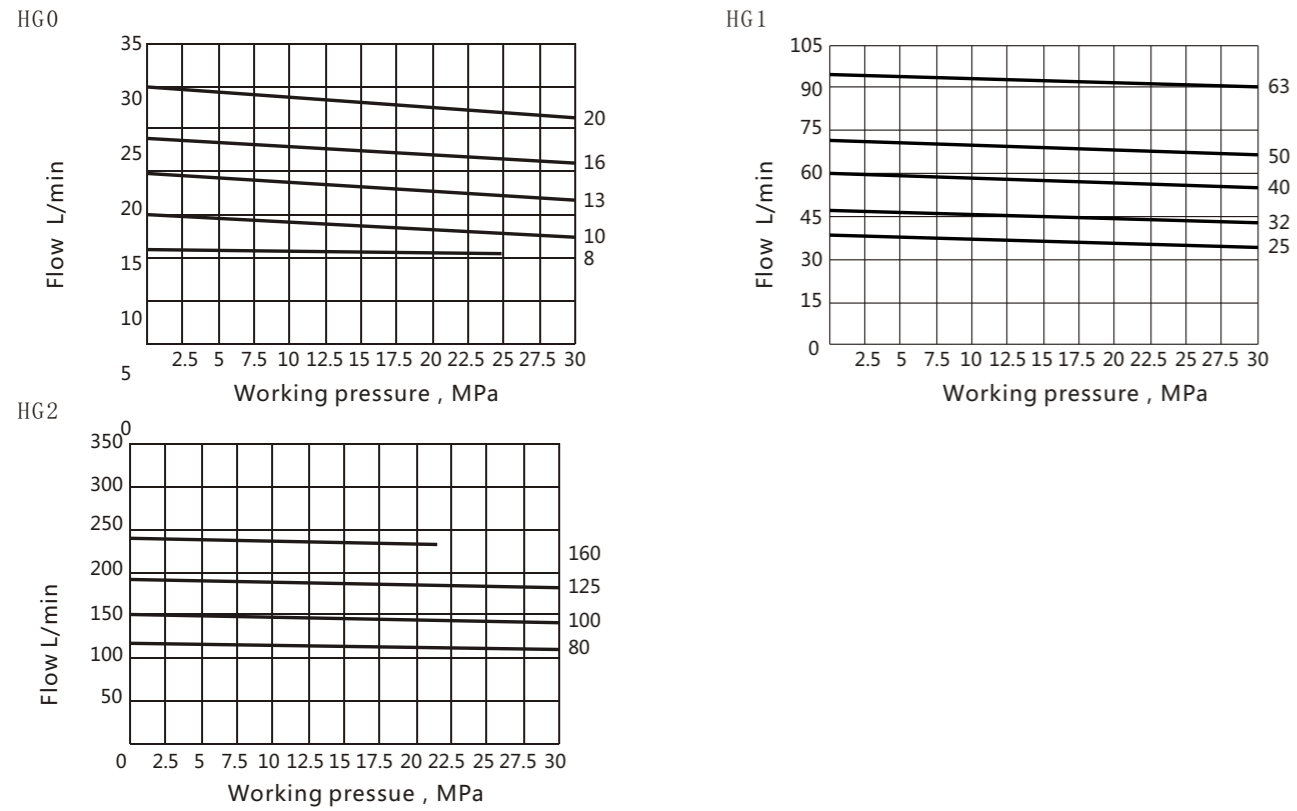

NOISE DIAGRAM

(Test condition: $n=1450\text{r/min}$, $v=46\text{mm}^2/\text{s}$, $t=50^\circ\text{C}$ The distance between detector and pump=1m)

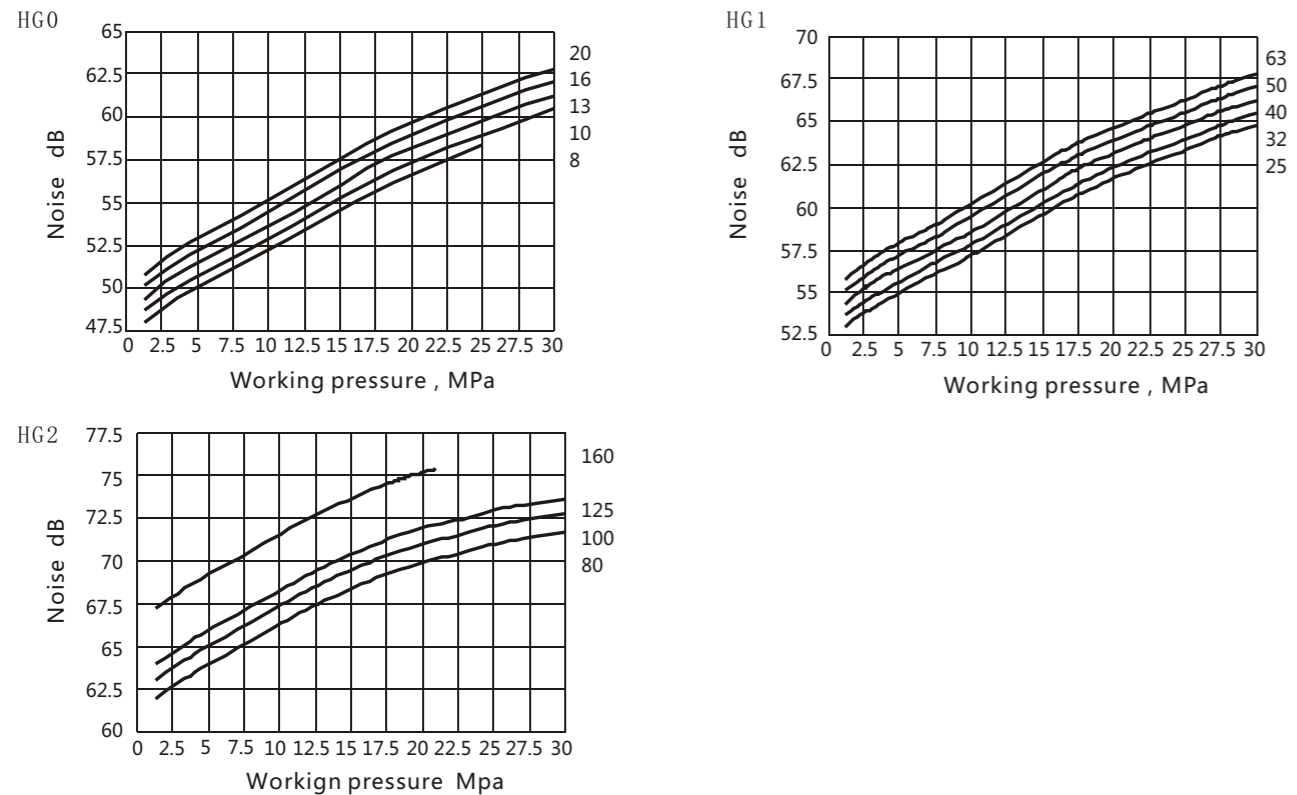

HG0-※-01R-VPC (P SHAFT)

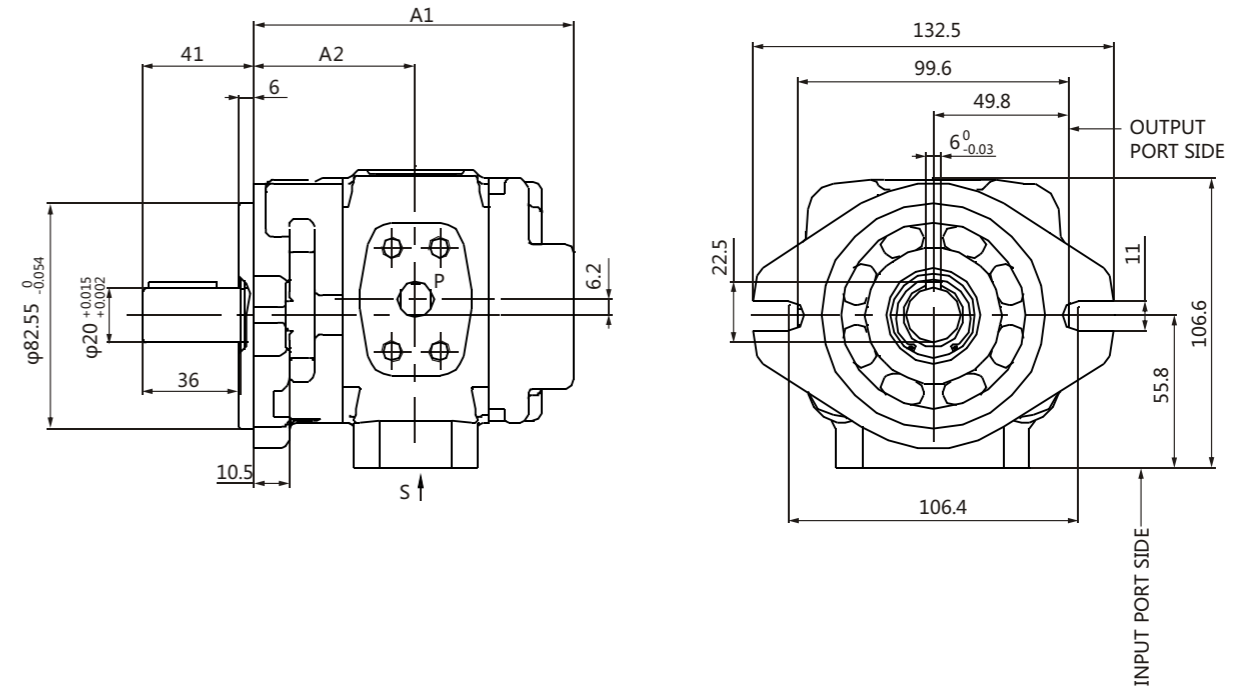

MODEL CODE	A1	A2	S	P
HG0-08-01R-VPC	107	54	$\phi 19$	$\phi 13$
HG0-10-01R-VPC	111	56		
HG0-13-01R-VPC	117.5	59.25		
HG0-16-01R-VPC	123	62	$\phi 26$	$\phi 18$
HG0-20-01R-VPC	131	66		

● PORT FLANGE DIMENSION (PAGE 11)

HG0-※-01R-VSC (S SHAFT)

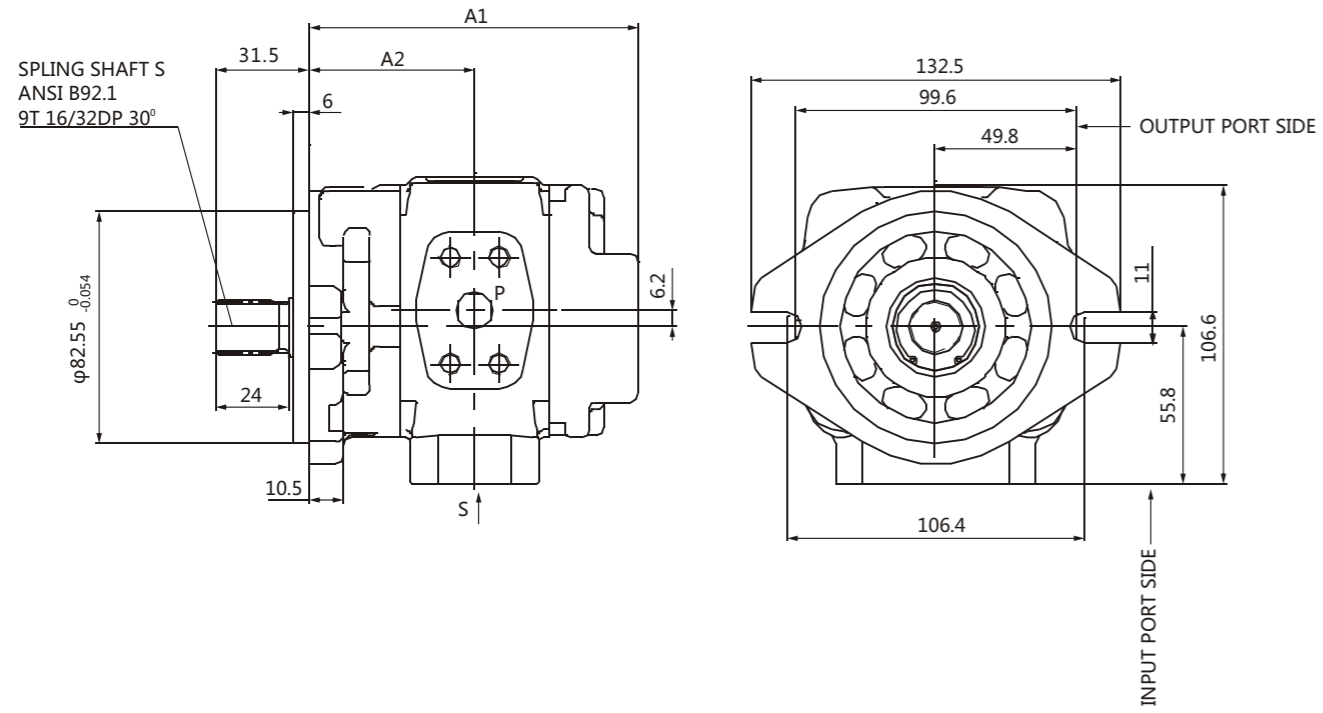

MODEL CODE	A1	A2	S	P
HG0-08-01R-VSC	107	54	φ 19	φ 13
HG0-10-01R-VSC	111	56		
HG0-13-01R-VSC	117.5	59.25		
HG0-16-01R-VSC	123	62	φ 26	φ 18
HG0-20-01R-VSC	131	66		

● PORT FLANGE DIMENTSION (PAGE 11)

HG1-※-01R-VPC (P SHAFT)

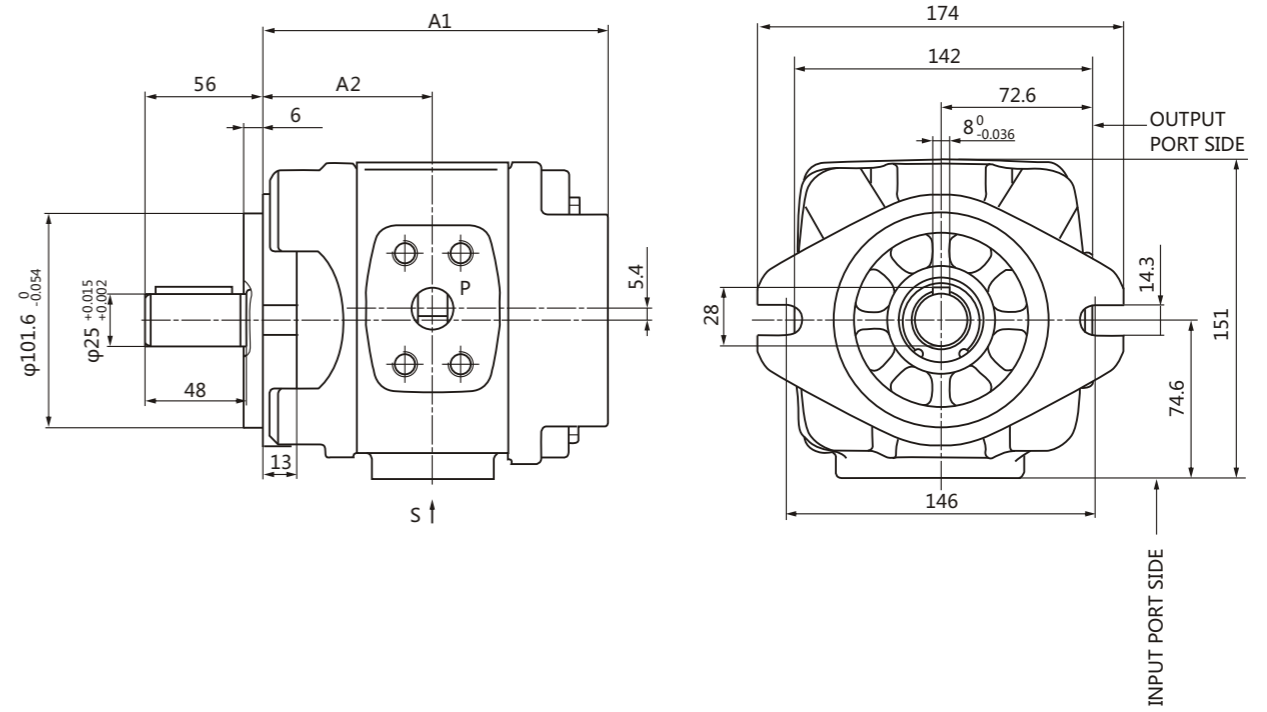

MODEL CODE	A1	A2	S	P
HG1-25-01R-VPC	139	73	φ 32	φ 18
HG1-32-01R-VPC	146	76.5		
HG1-40-01R-VPC	153	80		φ 20
HG1-50-01R-VPC	163	85		
HG1-63-01R-VPC	177	92		

● PORT FLANGE DIMENTSION (PAGE 11)

INSTALLATION DIMENSIONS

HG1-※-01R-VSC (S SHAFT)

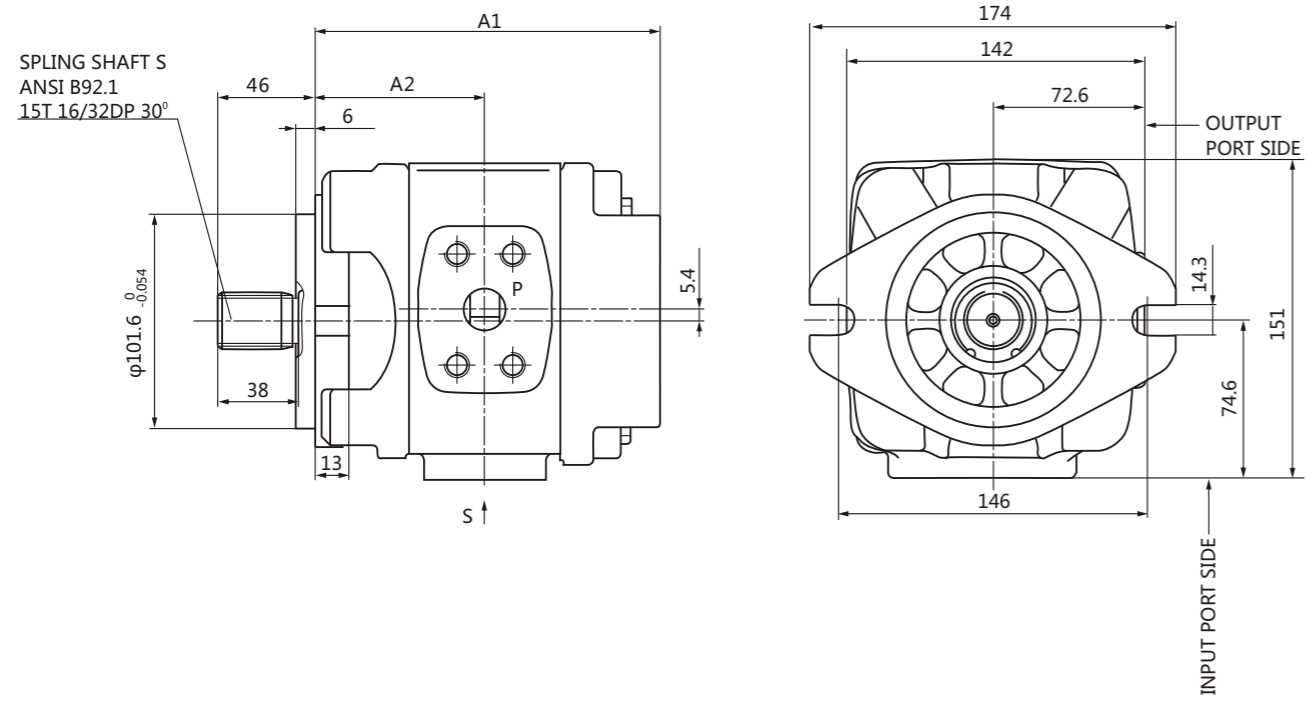

MODLE CODE	A1	A2	S	P
HG1-25-01R-VSC	139	73	φ 32	φ 18
HG1-32-01R-VSC	146	76.5		
HG1-40-01R-VSC	153	80		φ 20
HG1-50-01R-VSC	163	85		
HG1-63-01R-VSC	177	92		

● PORT FLANGE DIMENTSION (PAGE 11)

INSTALLATION DIMENSIONS

HG2-※-01R-VPC (P SHAFT)

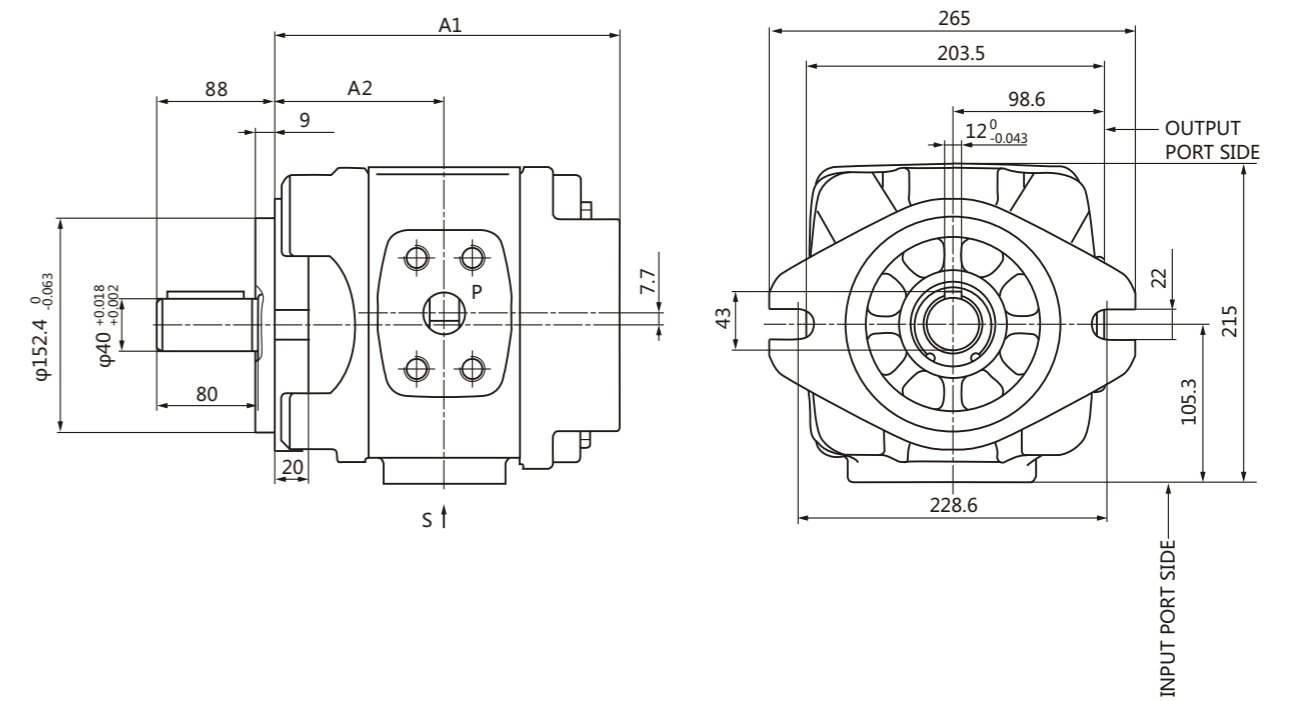

MODEL CODE	A1	A2	S	P
HG2-80-01R-VPC	204	109.5	φ 51	φ 32
HG2-100-01R-VPC	213	114		
HG2-125-01R-VPC	225	120	φ 63.5	φ 38
HG2-160-01R-VPC	243	129	φ 76	

● PORT FLANGE DIMENTSION (PAGE 11)

INSTALLATION DIMENSIONS

HG2-※-01R-VSC (S SHAFT)

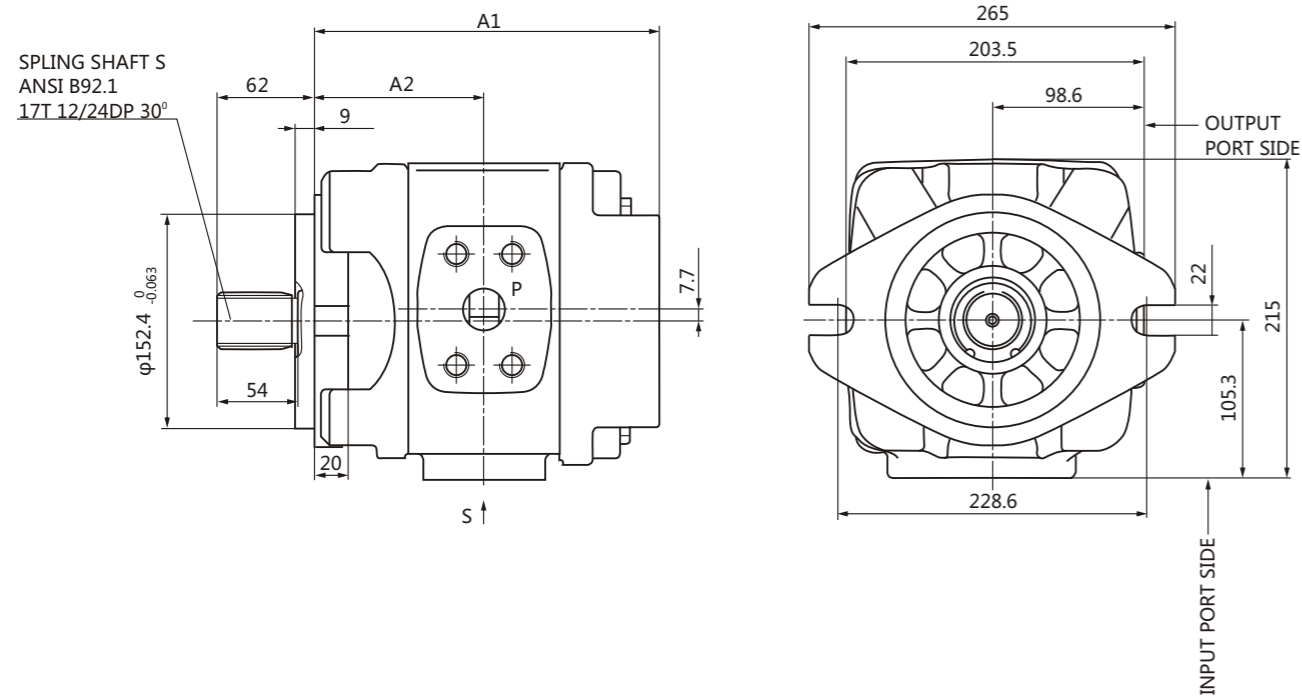

MODEL CODE	A1	A2	S	P
HG2-80-01R-VSC	204	109.5	φ 51	φ 32
HG2-100-01R-VSC	213	114		
HG2-125-01R-VSC	225	120	φ 63.5	φ 38
HG2-160-01R-VSC	243	129	φ 76	

● PORT FLANGE DIMENSIONS (PAGE 11)

PORT FLANGE DIMENSION

INPUT PORT "S"

OUTPUT PORT "P"

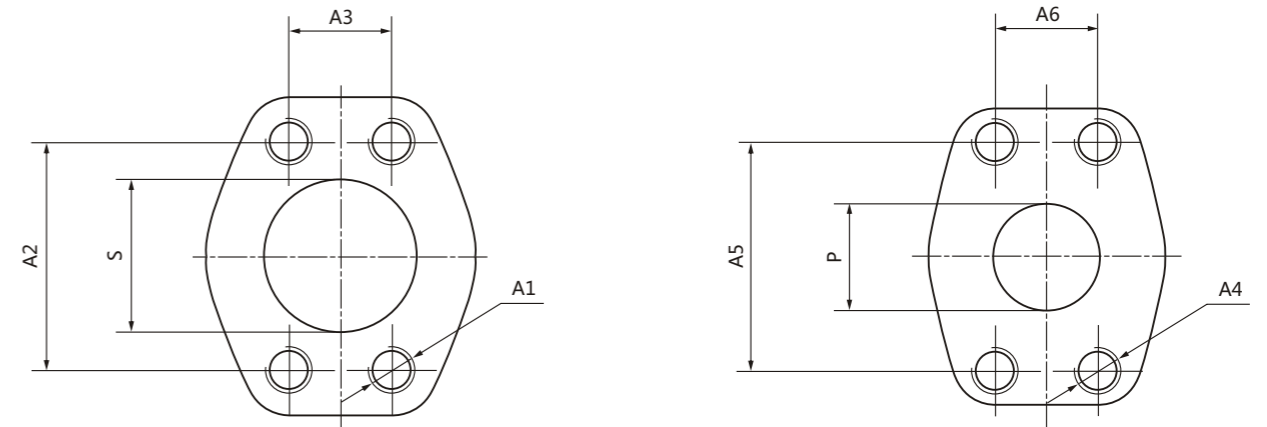

MODEL	SIZE8	S	A1	A2	A3	P	A4	A5	A6	
HG0	10	φ 19	M10 DEEP 15	47.6	22.2	φ 13	M8 DEEP 13	38.1	17.5	
	13			52.4	26.2					
	16			φ 26	58.7	30.2	φ 18	M10 DEEP 15	47.6	22.2
	20				58.7	30.2	φ 18	M10 DEEP 17	47.6	22.2
HG1	25	φ 32	M10 DEEP 17	58.7	30.2	φ 18	M10 DEEP 17	52.4	26.2	
	32					φ 20				
	40					φ 20	52.4	26.2		
	50						52.4	26.2		
	63						52.4	26.2		
HG2	80	φ 50	M12 DEEP 20	77.8	42.9	φ 32	M12 DEEP 20	69.9	35.7	
	100									
	125	φ 63.5	88.9	50.8	φ 38	M16 DEEP 25	79.4	36.5		
	160	φ 76	M16 DEEP 25	106.4					61.9	

INSTALLATION DIMENSIONS

HG10-※-※-01R-VSC (S SHAFT)

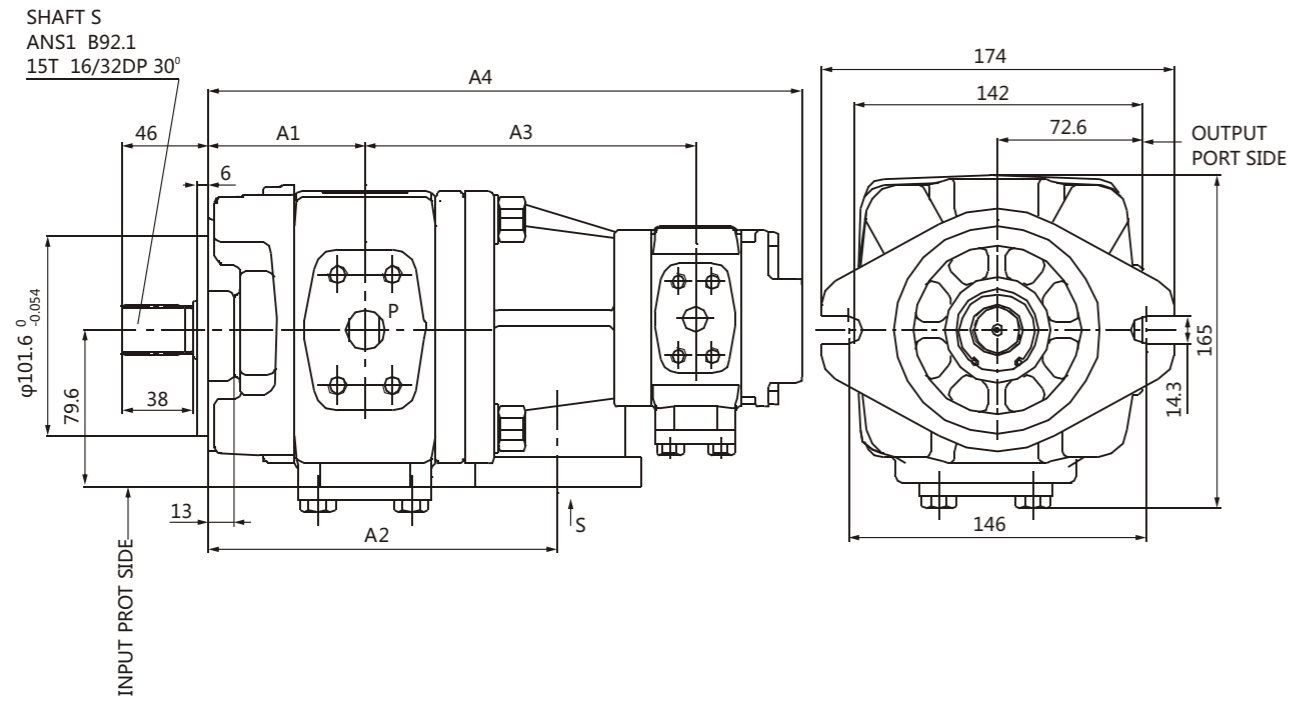

MODEL CODE	A1	A2	REAR PUMP DIMENSIONS									
			08		10		13		16		20	
			A3	A4	A3	A4	A3	A4	A3	A4	A3	A4
HG10-25-※-01R-VSC	73	164.5	160.5	286.5	162.5	290.5	165.8	297	168.5	302.5	172.5	310.5
HG10-32-※-01R-VSC	76.5	171.5	164	293.5	166	297.5	169.3	304	172	309.5	176	317.5
HG10-40-※-01R-VSC	80	178.5	167.5	300.5	169.5	304.5	172.8	311	175.5	316.5	179.5	324.5
HG10-50-※-01R-VSC	85	188.5	172.5	310.5	174.5	314.5	177.8	321	180.5	326.5	184.5	334.5
HG10-63-※-01R-VSC	92	202.5	179.5	324.5	181.5	328.5	184.8	335	187.5	340.5	191.5	348.5

- INPUT PORT FLANGE DIMENSION (PAGE 11)
- OUTPUT PORT FLANGE DIMENSION (PAGE 21)

INSTALLATION DIMENSIONS

HG11-※-※-01R-VPC (P SHAFT)

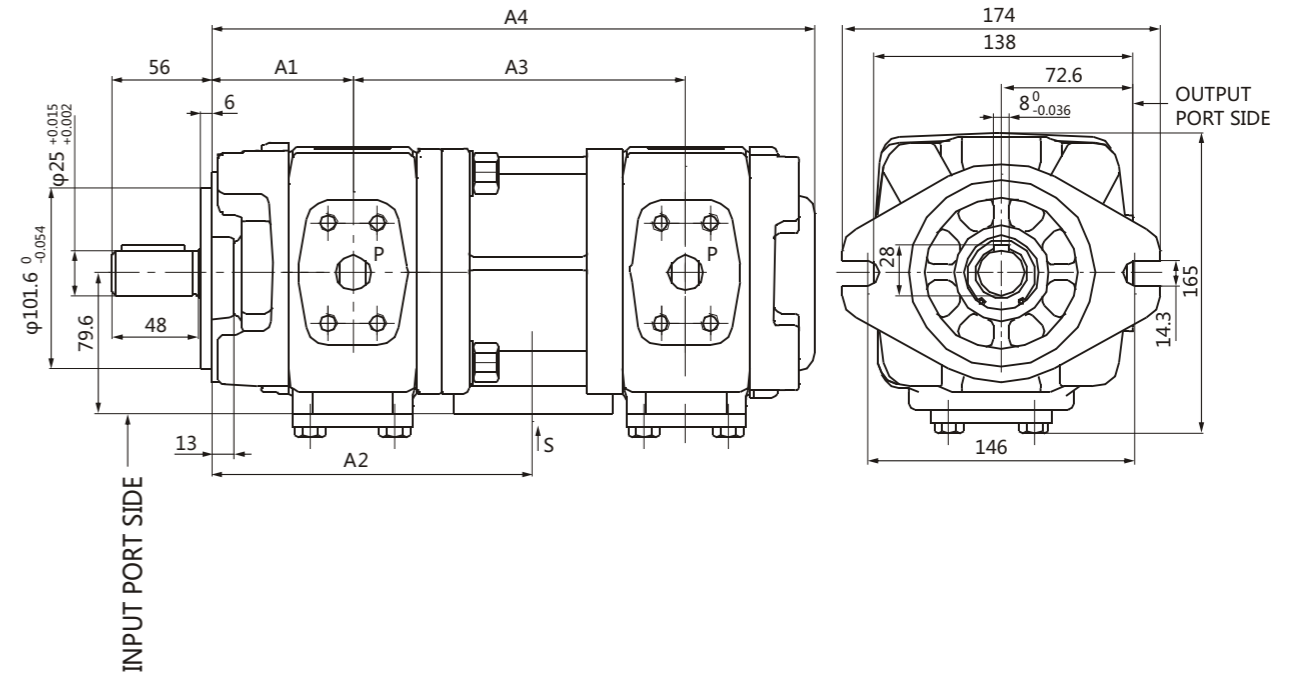

MODEL CODE	A1	A2	REAR PUMP DIMENSIONS									
			25		32		40		50		63	
			A3	A4	A3	A4	A3	A4	A3	A4	A3	A4
HG11-25-※-01R-VPC	73	168	175	314								
HG11-32-※-01R-VPC	76.5	175	178.5	321	182	328						
HG11-40-※-01R-VPC	80	182	182	328	185.5	335	189	342				
HG11-50-※-01R-VPC	85	192	187	338	190.5	345	194	352	199	362		
HG11-63-※-01R-VPC	92	206	194	352	197.5	359	201	366	206	376	213	390

- INPUT PORT FLANGE DIMENSION (PAGE 11)
- OUTPUT PORT FLANGE DIMENSION (PAGE 21)

INSTALLATION DIMENSIONS

HG11-※-※-01R-VSC (S SHAFT)

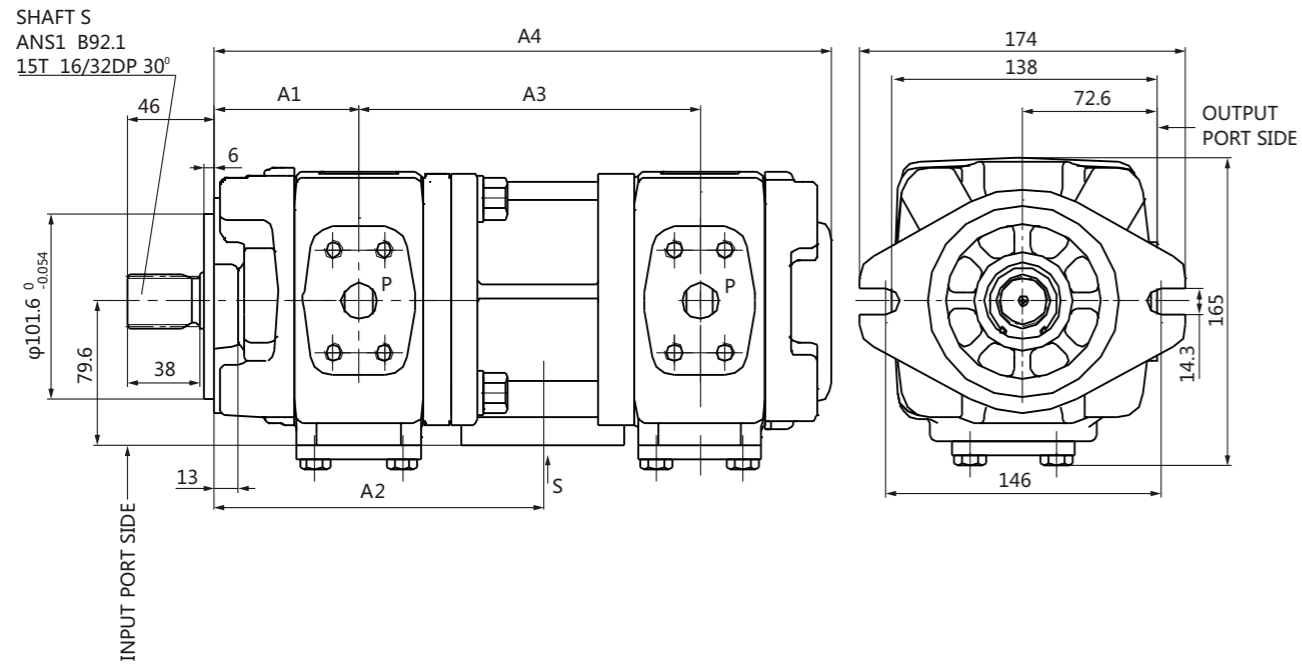

MODEL CODE	A1	A2	REAR PUMP DIMENSIONS										
			25		32		40		50		63		
			A3	A4	A3	A4	A3	A4	A3	A4	A3	A4	
HG11-25-※-01R-VSC	73	168	175	314									
HG11-32-※-01R-VSC	76.5	175	178.5	321	182	328							
HG11-40-※-01R-VSC	80	182	182	328	185.5	335	189	342					
HG11-50-※-01R-VSC	85	192	187	338	190.5	345	194	352	199	362			
HG11-63-※-01R-VSC	92	206	194	352	197.5	359	201	366	206	376	213	390	

- INPUT PORT FLANGE DIMENSION (PAGE 11)
- OUTPUT PORT FLANGE DIMENSION (PAGE 21)

INSTALLATION DIMENSIONS

HG21-※-※-01R-VPC (P SHAFT)

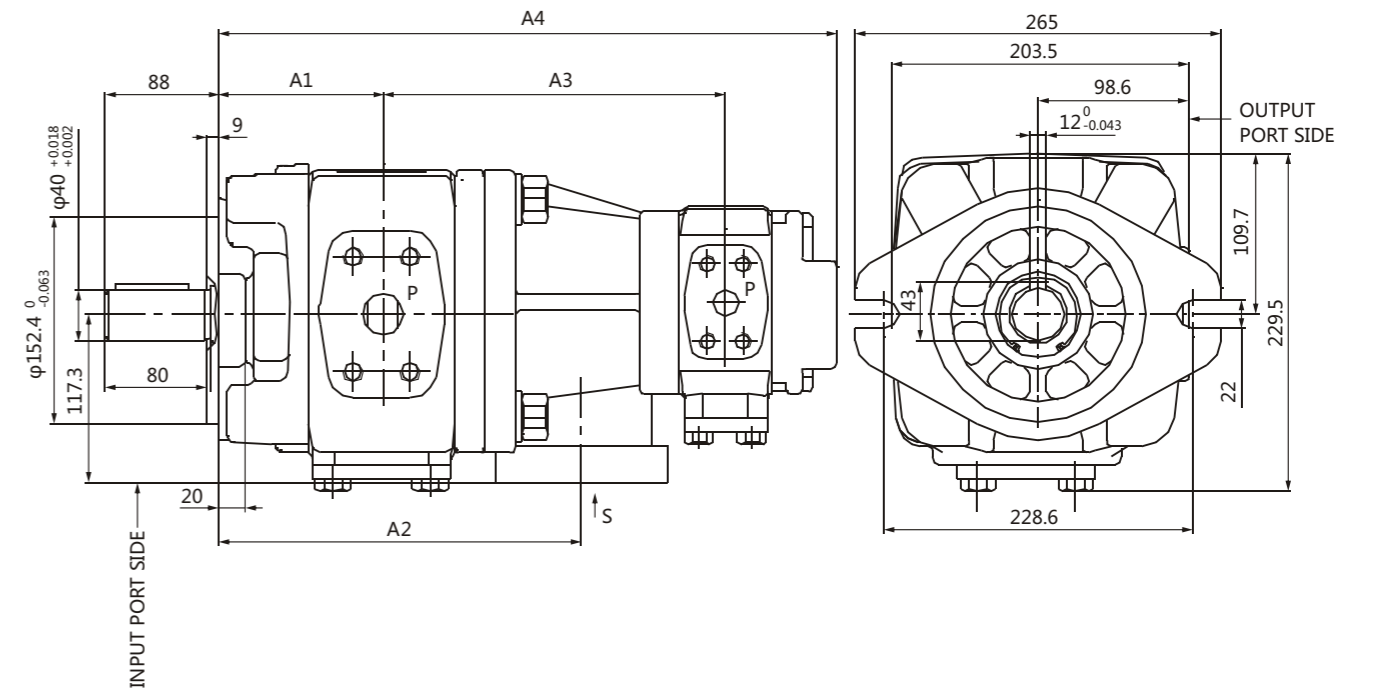

MODE CODE	A1	A2	REAR PUMP DIMENSIONS									
			25		32		40		50		63	
			A3	A4	A3	A4	A3	A4	A3	A4	A3	A4
HG21-80-※-01R-VPC	109.5	249.5	241.5	417	245	424	248.5	431	253.5	441	260.5	455
HG21-100-※-01R-VPC	114	258.5	246	426	249.5	433	253	440	258	450	265	464
HG21-125-※-01R-VPC	120	270.5	252	438	255.5	445	259	452	264	462	271	476
HG21-160-※-01R-VPC	129	288.5	261	456	264.5	463	268	470	273	480	280	494

- INPUT PORT FLANGE DIMENSION (PAGE 11)
- OUTPUT PORT FLANGE DIMENSION (PAGE 21)

INSTALLATION DIMENSIONS

HG21-※-※-01R-VSC (S SHAFT)

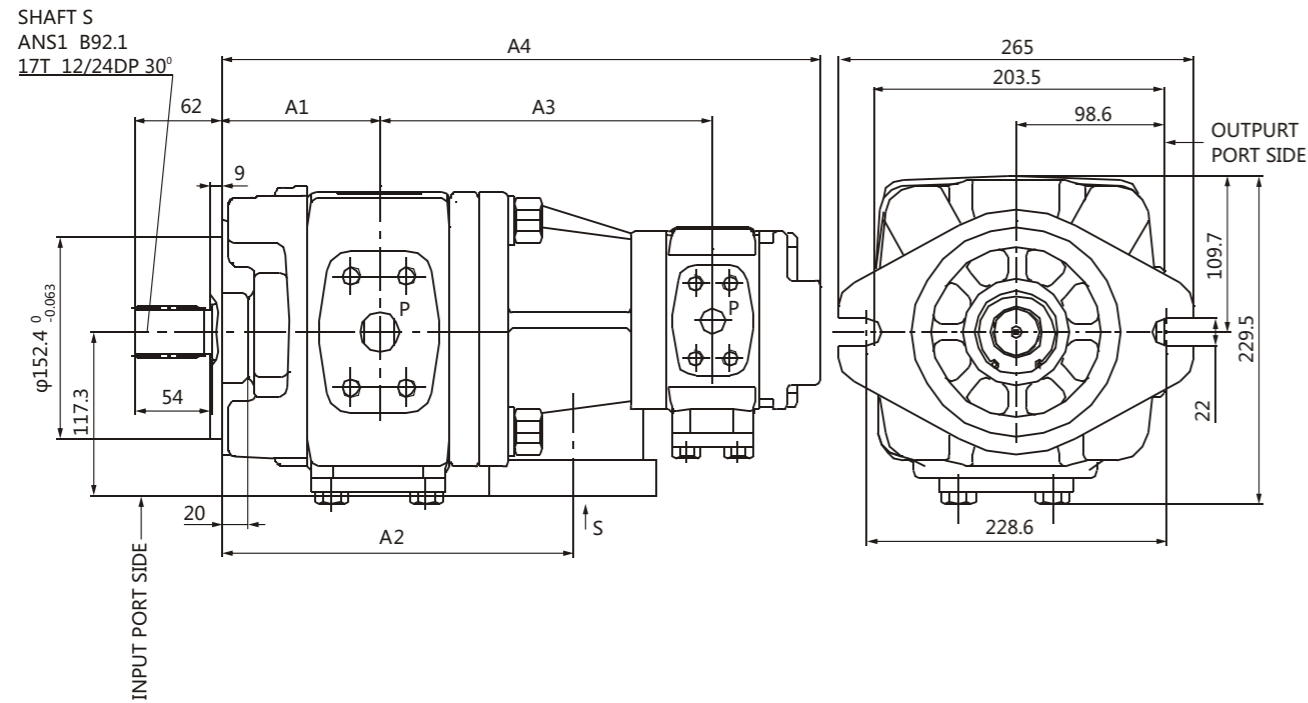

MODEL CODE	A1	A2	REAR PUMP DIMENSIONS									
			25		32		40		50		63	
			A3	A4	A3	A4	A3	A4	A3	A4	A3	A4
HG21-80-※-01R-VSC	109.5	249.5	241.5	417	245	424	248.5	431	253.5	441	260.5	455
HG21-100-※-01R-VSC	114	258.5	246	426	249.5	433	253	440	258	450	265	464
HG21-125-※-01R-VSC	120	270.5	252	438	255.5	445	259	452	264	462	271	476
HG21-160-※-01R-VSC	129	288.5	261	456	264.5	463	268	470	273	480	280	494

- INPUT PORT FLANGE DIMENSION (PAGE 11)
- OUTPUT PORT FLANGE DIMENSION (PAGE 21)

INSTALLATION DIMENSIONS

HG22-※-※-01R-VPC (P SHAFT)

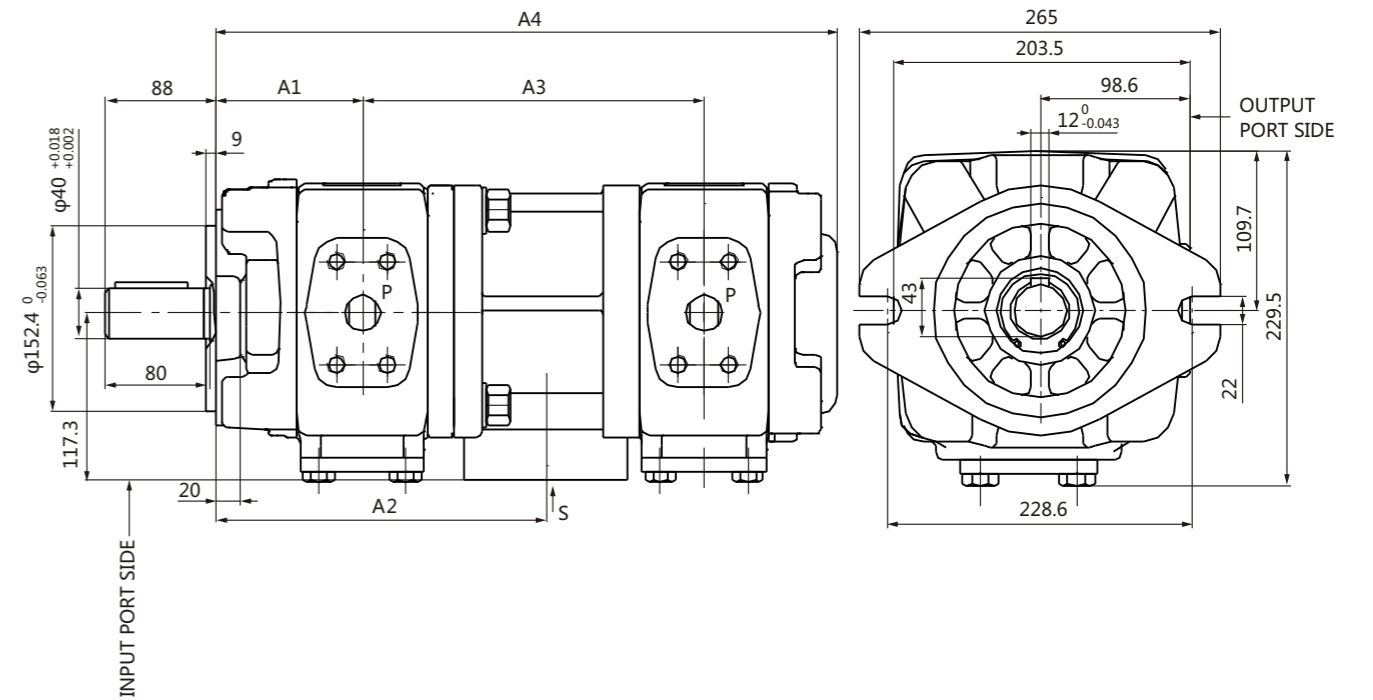

MODEL CODE	A1	A2	REAR PUMP DIMENSIONS									
			80		100		125		160			
			A3	A4	A3	A4	A3	A4	A3	A4		
HG22-80-※-01R-VPC	109.5	257	270	474								
HG22-100-※-01R-VPC	114	266	274.5	483	279	492						
HG22-125-※-01R-VPC	120	278	280.5	495	285	504	291	516				
HG22-160-※-01R-VPC	129	296	289.5	513	294	522	300	534	309	552		

- INPUT PORT FLANGE DIMENSION (PAGE 11)
- OUTPUT PORT FLANGE DIMENSION (PAGE 21)

HG22-※-※-01R-VSC (S SHAFT)

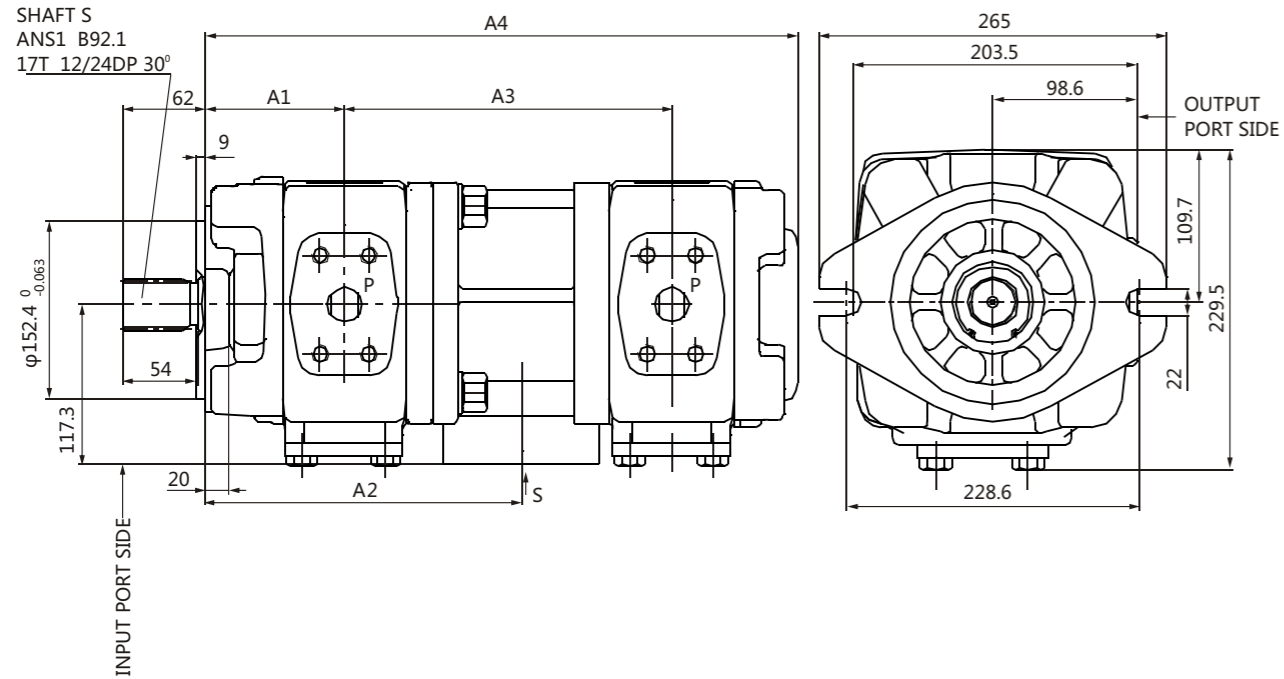

MODEL CODE	A1	A2	REAR PUMP DIMENSIONS							
			80		100		125		160	
			A3	A4	A3	A4	A3	A4	A3	A4
HG22-80-※-01R-VSC	109.5	257	270	474						
HG22-100-※-01R-VSC	114	266	274.5	483	279	492				
HG22-125-※-01R-VSC	120	278	280.5	495	285	504	291	516		
HG22-160-※-01R-VSC	129	296	289.5	513	294	522	300	534	309	552

- INPUT PORT FLANGE DIMENSION (PAGE 11)
- OUTPUT PORT FLANGE DIMENSION (PAGE 21)

INPUT PORT "S"

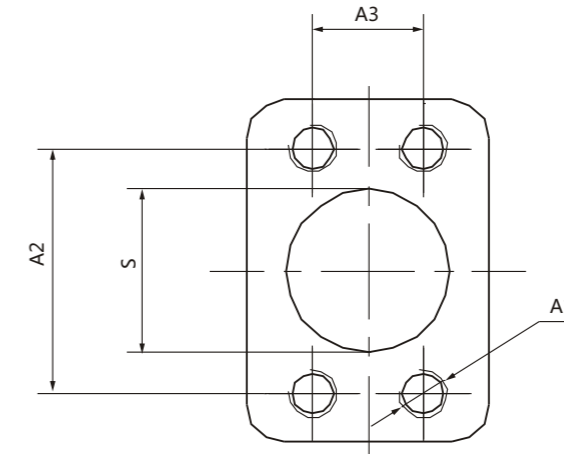

MODEL	S	A1	A2	A3
HG10	φ 51	M12 DEEP 20	77.8	42.9
HG11	φ 60		88.9	50.8
HG21	φ 89	M16 DEEP 25	120.7	69.9
HG22	φ 102		130.2	77.8

NOTICE

- OIL**
Can be used in petroleum based mineral oil viscosity in the range of 10-300mm²/s, recommend the use of ISO VG46 anti-wear hydraulic oil.
- TEMPERATURE**
Working temperature range -10°C—100°C, the best range is 20°C—80°C。
- CLEANSNESS OF OIL**
Lower than NAS 1638 or 17/14 (iso 4066)
- INSTALLATION**
The shaft is connected with the motor using the flexible coupling produced as much as possible, or to avoid bending moment axial thrust, shaft and motor shaft maximum allowable coaxiality error less than 0.15mm
- THE SUCTION PRESSURE AND PIPING**
Allow the suction inlet absolute pressure of 0.2-2 Bar. Reasonable piping through suction diameter should be not less than the pump export, to ensure that the average 0.6-1.2m/s best oil absorption speed.
- IMPORT AND EXPORT CONNECTION**
Try to avoid using hard wired import steel tubing, recommend the use of rubber hose, to avoid the additional load cause additional noise.
- EXHAUST**
In the first before the operation, should be used to pump oil way exhaust valve added, excluding the pump and pipeline system in the air, if the pump or pipe of air in the residue will result in. The vibration and noise of the pump, and indirectly affect the service life of the pump.
- MAINTAIN**
In order to improve the service life of the pump, should abnormal vibration, periodic inspection of the system noise, oil temperature, the fuel tank if bubbles generated and no leakage and other issues.