

## PV Series Variable Displacement Pump



**PV016 to PV270**

Open Curcirt, Norminal Pressure 350 bar

Peak Pressure 420 bar

# Ordering code

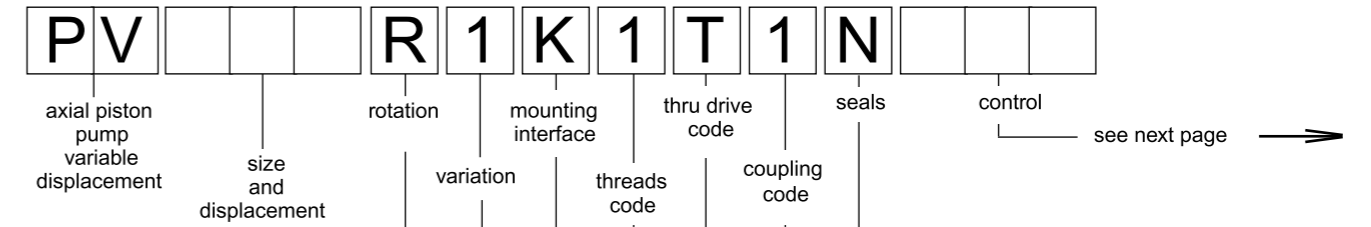

Code	Displacement	Size
016	16 cm³/rev	1
020	20 cm³/rev	1
023	23 cm³/rev	1
028	28 cm³/rev	1

Code	Seals
N	NBR
V	FPM
W	NBR with PTFE shaft seal
P	FPM with PTFE shaft seal

Code	Rotation <sup>1)</sup>
R	Clockwise
L	Counter clockwise

<sup>1)</sup> When looked on shaft

Code	Variation
1	Standard
9	Special adjustment <sup>2)</sup>

<sup>2)</sup> requires Kxxxx number

Code	Mounting interface	Shaft
K	metr. ISO 4-hole flange Ø100 mm	Cylindric, key
L	3019/2 4-hole flange Ø100 mm	Splined, DIN 5480
D	SAE 4-hole flange SAE B	Cylindric, key
E	ISO 4-hole flange SAE B-B	Splined, SAE

Code	Port <sup>3)</sup>	Threads <sup>4)</sup>
1	BSPP	metric
3	UNF	UNC
7	ISO 6149	UNC
8 <sup>5)</sup>	ISO 6149	metric

3) Drain, gauge and flushing ports  
 4) All mounting and connecting threads  
 5) Mounting interface, code K and L only

Code	Coupling for thru drive	as single part <sup>6)</sup>
1	Single pump, no coupling	
H	with coupling 25 x 1.5 x 15, DIN 5480	MK-PVBGxK01
Y	with coupling SAE A 9T-16/32 DP	MK-PVBGxK11
A	with coupling SAE - 11T-16/32 DP	MK-PVBGxK12
B	with coupling SAE B 13T-16/32 DP	MK-PVBGxK13
C	with coupling SAE B-B 15T-16/32 DP	MK-PVBGxK14

Code	Thru drive option
No adaptor for 2nd pump	
T	Single pump prepared for thru drive
with adaptor for 2nd pump	
Y	SAE AA, Ø 50.8 mm
A	SAE A, Ø 82.55 mm
B	SAE B, Ø 101.6 mm
G	metric, Ø 63 mm
H	metric, Ø 80 mm
J	metric, Ø 100 mm

See dimensions for details  
<sup>6)</sup> to be ordered separately as single part  
 x= Frame size, see displacement.

## Ordering Code

Code			Control options
0	0	1	No control
1	0	0	With cover plate, no control function
M	M		Standard pressure control, integrated pilot valve
M	R		Remote pressure control, integrated pilot valve
M	F		Load Sensing (flow) control, integrated pilot valve
M	T		Two spool LS control
			Control variation
	C		Standard version <sup>1)</sup>
	1		NG6 interface top side for pilot valves
	W		With unloading function, 24VDC solenoid <sup>1)</sup>
	K		Prop.-pilot valve type PVACRE..35 mounted
	Z		Without integrated pilot valve, NG6 interface, for mounting of accessory code PVAC*
	P		MT1 with mounted pilot valve PVAC1P <sup>2)</sup>

1) not for MT  
2) only for MT

Horse power / Torque control			
Displacem.		Code	
016			Nominal HP at 1.500 rpm
028			Nominal torque
		B	3 kW / 20 Nm
		C	4 kW / 25 Nm
		D	5.5 kW / 35 Nm
		E	7.5 kW / 50 Nm
		G	11 kW / 71 Nm
		H	15 kW / 97 Nm
		K	18.5 kW / 120 Nm
Function			
		L	Horse power control with pressure control
		C	Horse power control with load sensing (single spool)
Control variation			
		C	Standard version
		1	NG 6 interface top side
		W	With unloading function, 24 VDC solenoid
		K	Prop.-pilot valve type PVACRE..35 mounted
		Z	Without integrated pilot valve, NG6 interface, for mounting of accessory code PVAC*

Code		Control option	
electro hydraulic control			
F	P	V	Proportional displacement control, no pressure compensation
U	P		Proportional displacement control, with pressure compensation
Control variation			
		R	pilot operated pressure control, open NG6 interface
		K	pilot operated pressure control, proportional pilot valve type PVACRE..35 mounted
		M	pilot operated pressure control, pressure sensor and proportional pilot valve type PVACRE..35 mounted for pressure control and/or power control

## Ordering Code

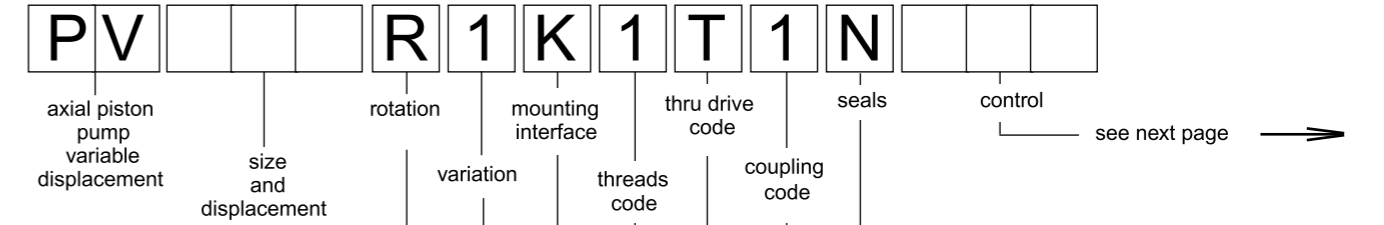

Code	Displacement	Size
032	32 cm <sup>3</sup> /rev	2
040	40 cm <sup>3</sup> /rev	2
046	46 cm <sup>3</sup> /rev	2

Code	Seals
N	NBR
V	FPM
W	NBR with PTFE shaft seal
P	FPM with PTFE shaft seal

Code	Rotation <sup>1)</sup>
R	Clockwise
L	Counter clockwise

<sup>1)</sup> When looked on shaft

Code	Variation
1	Standard
9	Special adjustment <sup>2)</sup>

<sup>2)</sup> requires Kxxxx number

Code	Mounting interface		Shaft
K	metr. ISO	4-hole flange Ø125 mm	Cylindric, key
L	3019/2	4-hole flange Ø125 mm	Splined, DIN 5480
D	SAE	4-hole flange SAE C	Cylindric, key
E	ISO	4-hole flange SAE C	Splined, SAE

Code	Port <sup>3)</sup>	Threads <sup>4)</sup>
1	BSPP	metric
3	UNF	UNC
7	ISO 6149	UNC
8 <sup>5)</sup>	ISO 6149	metric

3) Drain, gauge and flushing ports  
4) All mounting and connecting threads  
5) Mounting interface, code K and L only

Code	Coupling for thru drive	as single part <sup>6)</sup>
1	Single pump, no coupling	
H	with coupling 25 x 1.5 x 15, DIN 5480	MK-PVBGxK01
J	with coupling 32 x 1.5 x 20, DIN 5480	MK-PVBGxK02
Y	with coupling SAE A 9T-16/32 DP	MK-PVBGxK11
A	with coupling SAE - 11T-16/32 DP	MK-PVBGxK12
B	with coupling SAE B 13T-16/32 DP	MK-PVBGxK13
C	with coupling SAE B-B 15T-16/32 DP	MK-PVBGxK14
D	with coupling SAE C 14T-12/24 DP	MK-PVBGxK15

Code	Thru drive option	
No adaptor for 2nd pump		
T	Single pump prepared for thru drive	
with adaptor for 2nd pump		
		as single part <sup>6)</sup>
A	SAE A, Ø 82.55 mm	MK-PVBGxAMN
B	SAE B, Ø 101.6 mm	MK-PVBGxBMN
C	SAE C, Ø 127 mm	MK-PVBGxCMN
G	metric, Ø 63 mm	MK-PVBGxGMN
H	metric, Ø 80 mm	MK-PVBGxHMN
J	metric, Ø 100 mm	MK-PVBGxJMN
K	metric, Ø 125 mm	MK-PVBGxKMN

See dimensions for details  
<sup>6)</sup> to be ordered separately as single part  
x= Frame size, see displacement.

## Ordering Code

Code		Control options
0	0 1	No control
1	0 0	With cover plate, no control function
M	M	Standard pressure control, integrated pilot valve
M	R	Remote pressure control, integrated pilot valve
M	F	Load Sensing (flow) control, integrated pilot valve
M	T	Two spool LS control
		Control variation
	C	Standard version <sup>1)</sup>
	1	NG6 interface top side for pilot valves
	W	With unloading function, 24VDC solenoid <sup>1)</sup>
	K	Prop.-pilot valve type PVACRE..35 mounted
	Z	Without integrated pilot valve, NG6 interface, for mounting of accessory code PVAC*
	P	MT1 with mounted pilot valve PVAC1P <sup>2)</sup>

1) not for MT  
2) only for MT

Horse power / Torque control			
Displacem.	Code	Nominal HP at 1.500 rpm	Nominal torque
032			
046			
	D	5.5 kW	35 Nm
	E	7.5 kW	50 Nm
	G	11 kW	71 Nm
	H	15 kW	97 Nm
	K	18.5 kW	120 Nm
	M	22 kW	142 Nm
	S	30 kW	195 Nm
Function			
	L	Horse power control with pressure control	
	C	Horse power control with load sensing (single spool)	
Control variation			
	C	Standard version	
	1	NG 6 interface top side	
	W	With unloading function, 24 VDC solenoid	
	K	Prop.-pilot valve type PVACRE..35 mounted	
	Z	Without integrated pilot valve, NG6 interface, for mounting of accessory code PVAC*	

Code		Control option
electro hydraulic control		
F	P V	Proportional displacement control, no pressure compensation
U	P	Proportional displacement control, with pressure compensation
Control variation		
	R	pilot operated pressure control, open NG6 interface
	K	pilot operated pressure control, proportional pilot valve type PVACRE..35 mounted
	M	pilot operated pressure control, pressure sensor and proportional pilot valve type PVACRE..35 mounted for pressure control and/or power control

## Ordering Code

PV [ ] [ ] [ ] R 1 K 1 T 1 N [ ] [ ] [ ]

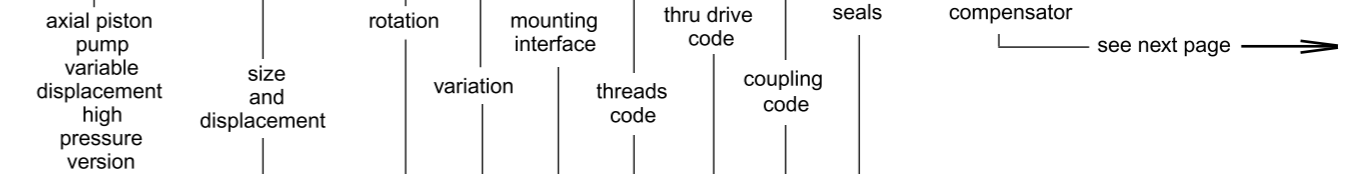

Code	Displacement	Size
063	63 cm <sup>3</sup> /rev	3
080	80 cm <sup>3</sup> /rev	3
092	92 cm <sup>3</sup> /rev	3

Code	Rotation <sup>1)</sup>
R	Clockwise
L	Counter clockwise

1) When looked on shaft

Code	Variation
1	Standard
9	special adjustment <sup>2)</sup>

2) requires Kxxxx number

Code	Mounting interface	Shaft
K	metr. ISO 4-hole flange Ø160 mm	Cylindric, key
L	3019/2 4-hole flange Ø160 mm	Splined, DIN 5480
D	SAE 4-hole flange SAE D	Cylindric, key
E	ISO 3019/1 4-hole flange SAE D	Splined, SAE

Code	Port <sup>3)</sup>	Threads <sup>4)</sup>
1	BSPP	metric
3	UNF	UNC
4 <sup>5)</sup>	BSPP	metr. M14
7	ISO 6149	UNC
8	ISO 6149	metric

3) Drain, gauge and flushing ports  
4) All mounting and connecting threads  
5) For PV063-PV092 only: pressure port 1 1/4" with 4 x M14 instead of 4 x M12

Code	Seals
N	NBR
V	FPM
W	NBR with PTFE shaft seal
P	FPM with PTFE shaft seal

Code	Coupling for thru drive	as single part <sup>6)</sup>
1	Single pump, no coupling	
H	with coupling 25 x 1.5 x 15, DIN 5480	MK-PVBGxK01
J	with coupling 32 x 1.5 x 20, DIN 5480	MK-PVBGxK02
K	with coupling 40 x 1.5 x 25, DIN 5480	MK-PVBGxK03
Y	with coupling SAE A 9T-16/32 DP	MK-PVBGxK11
A	with coupling SAE - 11T-16/32 DP	MK-PVBGxK12
B	with coupling SAE B 13T-16/32 DP	MK-PVBGxK13
C	with coupling SAE B-B 15T-16/32 DP	MK-PVBGxK14
D	with coupling SAE C 14T-12/24 DP	MK-PVBGxK15
E	with coupling SAE C - C	MK-PVBGxK16
F	with coupling SAE D, E	MK-PVBGxK17

Code	Thru drive option	
No adaptor for 2nd pump		
T	Single pump prepared for thru drive	
with adaptor for 2nd pump		
as single part <sup>6)</sup>		
A	SAE A, Ø 82.55 mm	MK-PVBGxAMN
B	SAE B, Ø 101.6 mm	MK-PVBGxBMN
C	SAE C, Ø 127 mm	MK-PVBGxCMN
D	SAE D, Ø 152.4 mm	MK-PVBGxDMN
G	metric, Ø 63 mm	MK-PVBGxGMN
H	metric, Ø 80 mm	MK-PVBGxHMN
J	metric, Ø 100 mm	MK-PVBGxJMN
K	metric, Ø 125 mm	MK-PVBGxKMN
L	metric, Ø 160 mm	MK-PVBGxLMN

See dimensions for details  
6) to be ordered separately as single part  
x= Frame size, see displacement.

## Ordering Code

Code			Control options
0	0	1	No control
1	0	0	With cover plate, no control function
M	M		Standard pressure control, integrated pilot valve
M	R		Remote pressure control, integrated pilot valve
M	F		Load Sensing (flow) control, integrated pilot valve
M	T		Two spool LS control
			Control variation
	C	1	Standard version <sup>1)</sup>
	W		NG6 interface top side for pilot valves
	K		With unloading function, 24VDC solenoid <sup>1)</sup>
	Z		Prop.-pilot valve type PVACRE..35 mounted
	P		Without integrated pilot valve, NG6 interface, for mounting of accessory code PVAC*
			MT1 with mounted pilot valve PVAC1P <sup>2)</sup>

1) not for MT  
2) only for MT

Horse power / Torque control			
Displacem.	Code	Nominal HP at 1.500 rpm	Nominal torque
063			
092			
	G	11 kW	71 Nm
	H	15 kW	97 Nm
	K	18.5 kW	120 Nm
	M	22kW	142 Nm
	S	30 kW	195 Nm
	T	37 kW	240 Nm
	U	45 kW	290 Nm
	W	55 kW	355 Nm
Function			
	L	Horse power control with pressure control	
	C	Horse power control with load sensing (single spool)	
Control variation			
	C	Standard version	
	1	NG 6 interface top side	
	W	With unloading function, 24 VDC solenoid	
	K	Prop.-pilot valve type PVACRE..35 mounted	
	Z	Without integrated pilot valve, NG6 interface, for mounting of accessory code PVAC*	

Code	Control option
electro hydraulic control	
F P V	Proportional displacement control, no pressure compensation
U P	Proportional displacement control, with pressure compensation
Control variation	
R	pilot operated pressure control, open NG6 interface
K	pilot operated pressure control, proportional pilot valve type PVACRE..35 mounted
M	pilot operated pressure control, pressure sensor and proportional pilot valve type PVACRE..35 mounted for pressure control and/or power control

## Ordering Code

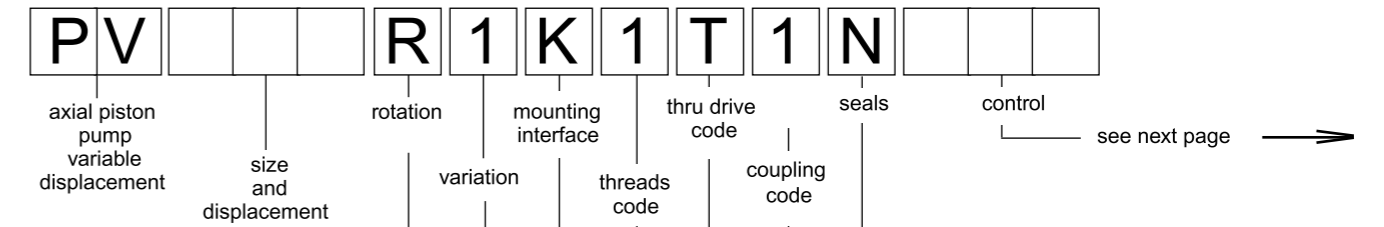

Code	Displacement	Size
140	140 cm <sup>3</sup> /rev	4
180	180 cm <sup>3</sup> /rev	4

Code	Rotation <sup>1)</sup>
R	Clockwise
L	Counter clockwise

1) When looked on shaft

Code	Variation
1	Standard
9	Special adjustment <sup>2)</sup>

2) requires Kxxxx number

Code	Mounting interface	Shaft
K	metr. ISO 4-hole flange Ø160 mm	Cylindric, key
L	3019/2 4-hole flange Ø160 mm	Splined, DIN 5480
D	SAE 4-hole flange SAE D	Cylindric, key
E	ISO 4-hole flange SAE D-F	Splined, SAE
F	3019/1 4-hole flange SAE D	Cylindric, key
G	4-hole flange SAE D	Splined, SAE

Code	Port <sup>3)</sup>	Threads <sup>4)</sup>
1	BSPP	metric
3	UNF	UNC
4 <sup>5)</sup>	BSPP	metr. M14
7	ISO 6149	UNC
8 <sup>6)</sup>	ISO 6149	metric

3) Drain, gauge and flushing ports

4) All mounting and connecting threads

5) Pressure port 1 1/4" with 4 x M14 instead of 4 x M12

6) Mounting interface, code K and L only

Code	Seals
N	NBR
V	FPM
W	NBR with PTFE shaft seal
P	FPM with PTFE shaft seal

Code	Coupling for thru drive	as single part <sup>7)</sup>
1	Single pump, no coupling	
H	with coupling 25 x 1.5 x 15, DIN 5480	MK-PVBGxK01
J	with coupling 32 x 1.5 x 20, DIN 5480	MK-PVBGxK02
K	with coupling 40 x 1.5 x 25, DIN 5480	MK-PVBGxK03
L	with coupling 50 x 2 x 24, DIN 5480	MK-PVBGxK04
Y	with coupling SAE A 9T-16/32 DP	MK-PVBGxK11
A	with coupling SAE - 11T-16/32 DP	MK-PVBGxK12
B	with coupling SAE B 13T-16/32 DP	MK-PVBGxK13
C	with coupling SAE B-B 15T-16/32 DP	MK-PVBGxK14
D	with coupling SAE C 14T-12/24 DP	MK-PVBGxK15
E	with coupling SAE C - C	MK-PVBGxK16
F	with coupling SAE D, E	MK-PVBGxK17
G	with coupling SAE F	MK-PVBGxK18

Code	Thru drive option	
No adaptor for 2nd pump		
T	Single pump prepared for thru drive	
with adaptor for 2nd pump		
as single part <sup>7)</sup>		
A	SAE A, Ø 82.55 mm	MK-PVBGxAMN
B	SAE B, Ø 101.6 mm	MK-PVBGxBMN
C	SAE C, Ø 127 mm	MK-PVBGxCMN
D	SAE D, Ø 152.4 mm	MK-PVBGxDMN
H	metric, Ø 80 mm	MK-PVBGxHMN
J	metric, Ø 100 mm	MK-PVBGxJMN
K	metric, Ø 125 mm	MK-PVBGxKMN
L	metric, Ø 160 mm	MK-PVBGxLMN

See dimensions for details

7) to be ordered separately as single part  
x= Frame size, see displacement.

## Ordering Code

Code		Control options
0	0 1	No control
1	0 0	With cover plate, no control function
M	M	Standard pressure control, integrated pilot valve
M	R	Remote pressure control, integrated pilot valve
M	F	Load Sensing (flow) control, integrated pilot valve
M	T	Two spool LS control
		Control variation
	C	Standard version <sup>1)</sup>
	1	NG6 interface top side for pilot valves
	W	With unloading function, 24VDC solenoid <sup>1)</sup>
	K	Prop.-pilot valve type PVACRE..35 mounted
	Z	Without integrated pilot valve, NG6 interface, for mounting of accessory code PVAC*
	P	MT1 with mounted pilot valve PVAC1P <sup>2)</sup>

1) not for MT  
2) only for MT

Horse power / Torque control			
Displacem.	Code		
140 180			Nominal HP at 1.500 rpm
			Nominal torque
		K	18.5 kW / 120 Nm
		M	22 kW / 142 Nm
		S	30 kW / 195 Nm
		T	37 kW / 240 Nm
		U	45 kW / 290 Nm
		W	55 kW / 355 Nm
		Y	75 kW / 485 Nm
		Z	90 kW / 585 Nm
		2	110 kW / 715 Nm
Function			
		L	Horse power control with pressure control
		C	Horse power control with load sensing (single spool)
Control variation			
		C	Standard version
		1	NG 6 interface top side
		W	With unloading function, 24 VDC solenoid
		K	Prop.-pilot valve type PVACRE..35 mounted
		Z	Without integrated pilot valve, NG6 interface, for mounting of accessory code PVAC*

Code		Control option
electro hydraulic control		
F	P V	Proportional displacement control, no pressure compensation
U	P	Proportional displacement control, with pressure compensation
Control variation		
	R	pilot operated pressure control, open NG6 interface
	K	pilot operated pressure control, proportional pilot valve type PVACRE..35 mounted
	M	pilot operated pressure control, pressure sensor and proportional pilot valve type PVACRE..35 mounted for pressure control and/or power control

## Ordering Code

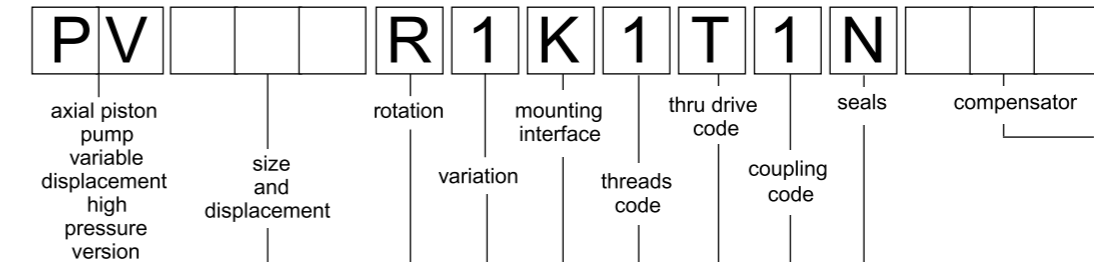

Code	Displacement	Size
270	270 cm³/rev	5

Code	Rotation <sup>1)</sup>
R	Clockwise
L	Counter clockwise

1) When looked on shaft

Code	Variation
1	Standard
9	special adjustment <sup>2)</sup>

2) requires Kxxxx number

Code	Mounting interface		Shaft
K	metr. ISO	4-hole flange Ø200 mm	Cylindric, key
L	3019/2	4-hole flange Ø200 mm	Splined, DIN 5480
D	SAE	4-hole flange SAE E	Cylindric, key
E	ISO	4-hole flange SAE E-F	Splined, SAE

Code	Port <sup>4)</sup>	Threads <sup>5)</sup>
1	BSP	metric
3	UNF	UNC
7	ISO 6149	UNC
8	ISO 6149	metric

4) Drain, gauge and flushing ports

5) All mounting and connecting threads  
See dimensions for details

6) to be ordered separately as single part  
x= Frame size, see displacement.

Code	Seals
N	NBR
V	FPM
W	NBR with PTFE shaft seal
P	FPM with PTFE shaft seal

Code	Coupling for thru drive	as single part <sup>6)</sup>
1	Single pump, no coupling	
H	with coupling 25 x 1.5 x 15, DIN 5480	MK-PVBGxK01
J	with coupling 32 x 1.5 x 20, DIN 5480	MK-PVBGxK02
K	with coupling 40 x 1.5 x 25, DIN 5480	MK-PVBGxK03
L	with coupling 50 x 2 x 24, DIN 5480	MK-PVBGxK04
M	with coupling 60 x 2 x 28, DIN 5480	MK-PVBGxK05
Y	with coupling SAE A 9T-16/32 DP	MK-PVBGxK11
A	with coupling SAE - 11T-16/32 DP	MK-PVBGxK12
B	with coupling SAE B 13T-16/32 DP	MK-PVBGxK13
C	with coupling SAE B-B 15T-16/32 DP	MK-PVBGxK14
D	with coupling SAE C 14T-12/24 DP	MK-PVBGxK15
E	with coupling SAE C - C	MK-PVBGxK16
F	with coupling SAE D, E	MK-PVBGxK17

Code	Thru drive option	
No adaptor for 2nd pump		
T	Single pump prepared for thru drive	
with adaptor for 2nd pump		
		as single part <sup>6)</sup>
A	SAE A, Ø 82.55 mm	MK-PVBGxAMN
B	SAE B, Ø 101.6 mm	MK-PVBGxBMN
C	SAE C, Ø 127 mm	MK-PVBGxCMN
D	SAE D, Ø 152.4 mm	MK-PVBGxDMN
E	SAE E, Ø 165.1 mm	MK-PVBGxEMN
H	metric, Ø 80 mm	MK-PVBGxHMN
J	metric, Ø 100 mm	MK-PVBGxJMN
K	metric, Ø 125 mm	MK-PVBGxKMN
L	metric, Ø 160 mm	MK-PVBGxLMN
M	metric, Ø 200 mm	MK-PVBGxMMN

## Ordering Code

Code		Control options	
0	0	1	No control
1	0	0	With cover plate, no control function
M	M		Standard pressure control, integrated pilot valve
M	R		Remote pressure control, integrated pilot valve
M	F		Load Sensing (flow) control, integrated pilot valve
M	T		Two spool LS control
			Control variation
	C		Standard version <sup>1)</sup>
	1		NG6 interface top side for pilot valves
	W		With unloading function, 24VDC solenoid <sup>1)</sup>
	K		Prop.-pilot valve type PVACRE..35 mounted
	Z		Without integrated pilot valve, NG6 interface, for mounting of accessory code PVAC*
	P		MT1 with mounted pilot valve PVAC1P <sup>2)</sup>

1) not for MT  
2) only for MT

Horse power / Torque control					
Displacem.	Code				
270				Nominal HP at 1.500 rpm	Nominal torque
		T		37 kW	240 Nm
		U		45 kW	290 Nm
		W		55 kW	350 Nm
		Y		75 kW	480 Nm
		Z		90 kW	580 Nm
		2		110 kW	700 Nm
		3		132 kW	840 Nm
Function					
		L		Horse power control with pressure control	
		C		Horse power control with load sensing (single spool)	
Control variation					
		C		Standard version	
		1		NG 6 interface top side	
		W		With unloading function, 24 VDC solenoid	
		K		Prop.-pilot valve type PVACRE..35 mounted	
		Z		Without integrated pilot valve, NG6 interface, for mounting of accessory code PVAC*	

Code		Control option	
electro hydraulic control			
F	P	V	Proportional displacement control, no pressure compensation
U	P		Proportional displacement control, with pressure compensation
Control variation			
	R		pilot operated pressure control, open NG6 interface
	K		pilot operated pressure control, proportional pilot valve type PVACRE..35 mounted
	M		pilot operated pressure control, pressure sensor and proportional pilot valve type PVACRE..35 mounted for pressure control and/or power control

## Technical Data

	PV016	PV020	PV023	PV028	PV032	PV040	PV046
Frame size	1	1	1	1	2	2	2
Max. Displacement [cm <sup>3</sup> /rev.]	16	20	23	28	32	40	46
Output flow at 1500 rpm [l/min]	24	30	34,5	42	48	60	69
Nominal pressure pN [bar]	350	350	350	350	350	350	350
Max. pressure pmax at 20% working cycle <sup>1)</sup> [bar]	420	420	420	420	420	420	420
Case drain pressure, continuous [bar]	0.5	0.5	0.5	0.5	0.5	0.5	0.55
Case drain pressure, max. peak [bar]	2.0	2.0	2.0	2.0	2.0	2.0	2.0
Min. Inlet pressure, abs. [bar]	0.8	0.8	0.8	0.8	0.8	0.8	0.8
Max. Inlet pressure [bar]	16	16	16	16	16	16	16
Input power at 1500 rpm and 350 bar [kW]	15.5	19.5	22.5	27.5	31	39	45
Max speed at 1 bar, abs, inlet pressure [rpm]	3000	3000	3000	3000	2800	2800	2800
Moment of inertia [kgm <sup>2</sup> ]	0.0017	0.0017	0.0017	0.0017	0.0043	0.0043	0.0043
Weight [kg]	19	19	19	19	30	30	30

	PV063	PV080	PV092	PV140	PV180	PV270
Frame size	3	3	3	4	4	5
Max. Displacement [cm <sup>3</sup> /rev.]	63	80	92	140	180	270
Output flow at 1500 rpm [l/min]	94.5	120	138	270	405	405
Nominal pressure pN [bar]	350	350	350	350	350	350
Max. pressure pmax at 20% working cycle <sup>1)</sup> [bar]	420	420	420	420	420	420
Case drain pressure, continuous [bar]	0.5	0.5	0.5	0.5	0.5	0.5
Case drain pressure, max. peak [bar]	2.0	2.0	2.0	2.0	2.0	2.0
Min. Inlet pressure, abs. [bar]	0.8	0.8	0.8	0.8	0.8	0.8
Max. Inlet pressure [bar]	16	16	16	16	16	16
Input power at 1500 rpm and 350 bar [kW]	61.5	78	89.5	136	175	263
Max speed at 1 bar, abs, inlet pressure [rpm]	2800	2500	2300	2400	2200	1800
Moment of inertia [kgm <sup>2</sup> ]	0.018	0.018	0.018	0.030	0.030	0.098
Weight [kg]	59	59	59	90	90	172

1) Special control options required.

#### PV016 - 028, metric version

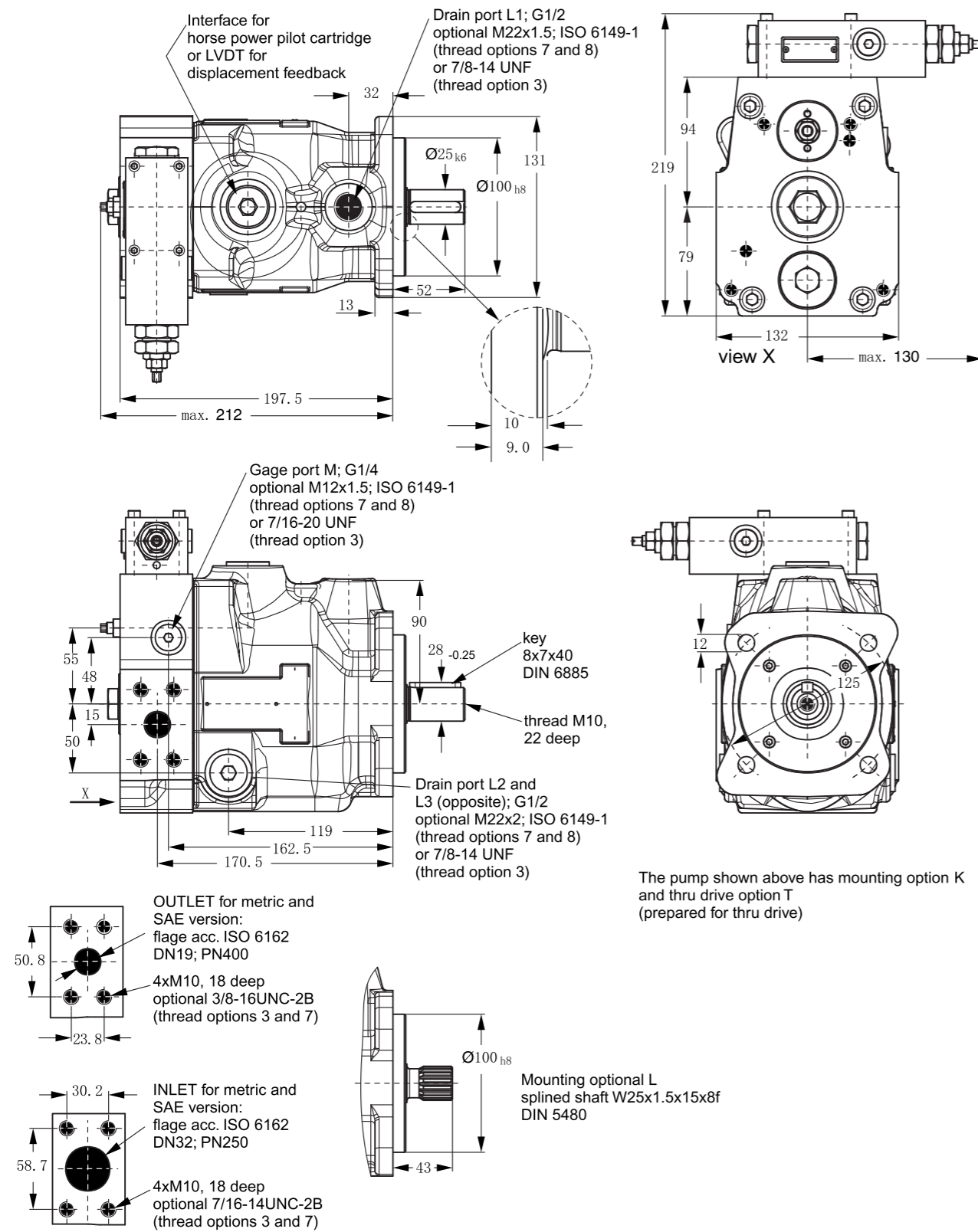

The pump shown above has mounting option K and thru drive option T (prepared for thru drive)

Shown is a clockwise rotating pump with standard pressure compensator. Counter clockwise rotating pumps have inlet, outlet and gauge port reversed.

#### PV016 - 028, SAE version

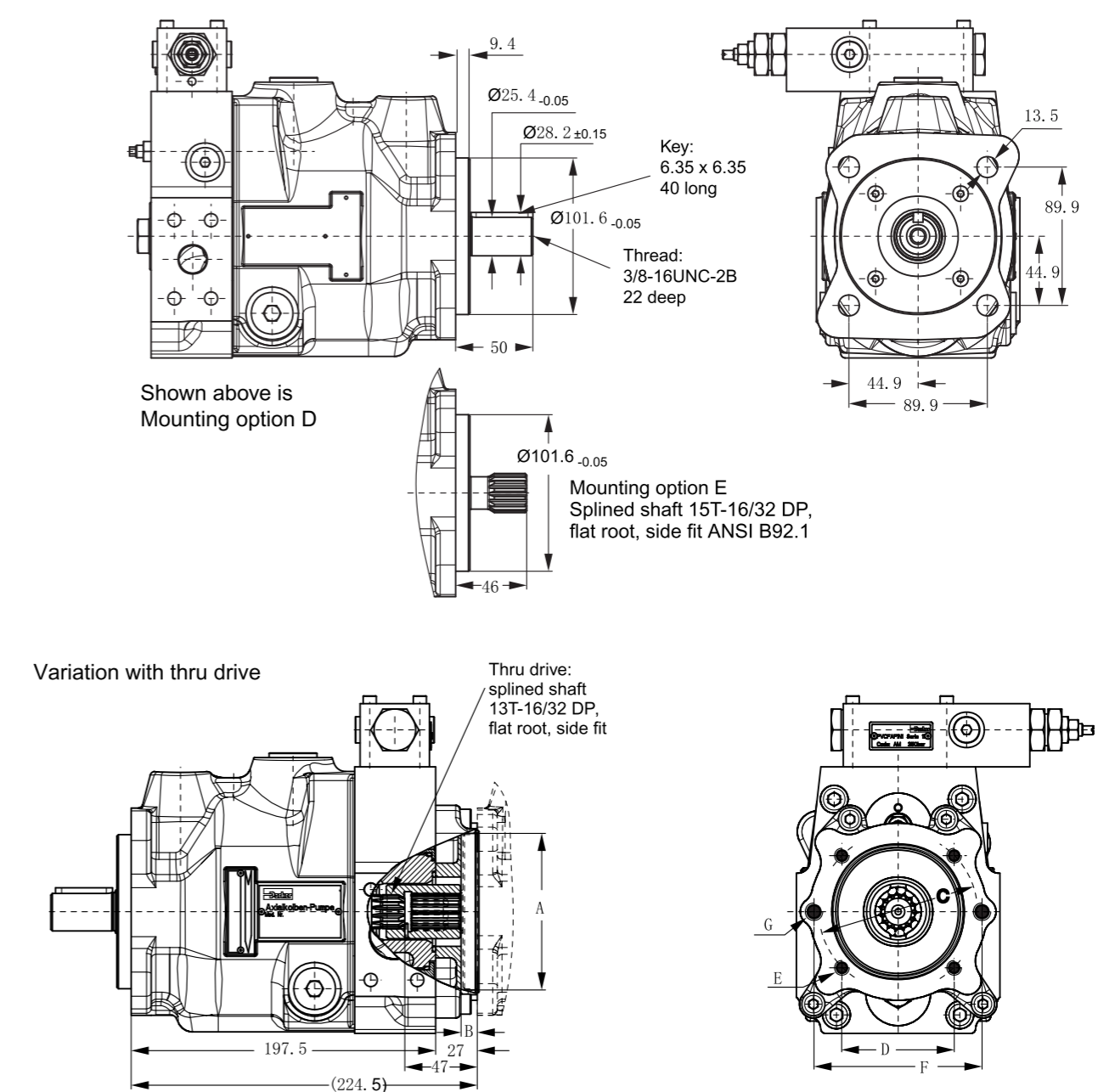

Thru drive adaptors are available with the following dimensions

Drawing Dimension	A	B	C	D	E		F	G		Remark
					Metr	UNC		Metr	UNC	
Y	50.8	8	-	-	-	-	82	M8	5/16"-18	SAE AA 2-Bolt
A	82.55	8	-	-	-	-	106	M10	3/8"-16	SAE A 2-Bolt
B	101.6	10.5	127	89.8	M12	1/2"-13	-	-	-	SAE B 4-Bolt
G	63	8.5	85	60.1	M8	5/16"-18	100	M8	5/16"-18	2/4-Bolt
H	80	8.5	103	72.8	M8	5/16"-18	109	M10	3/8"-16	2/4-Bolt
J	100	10.5	125	88.4	M10	3/8"-16	-	-	-	4-Bolt





#### PV 140 - 180 Metric

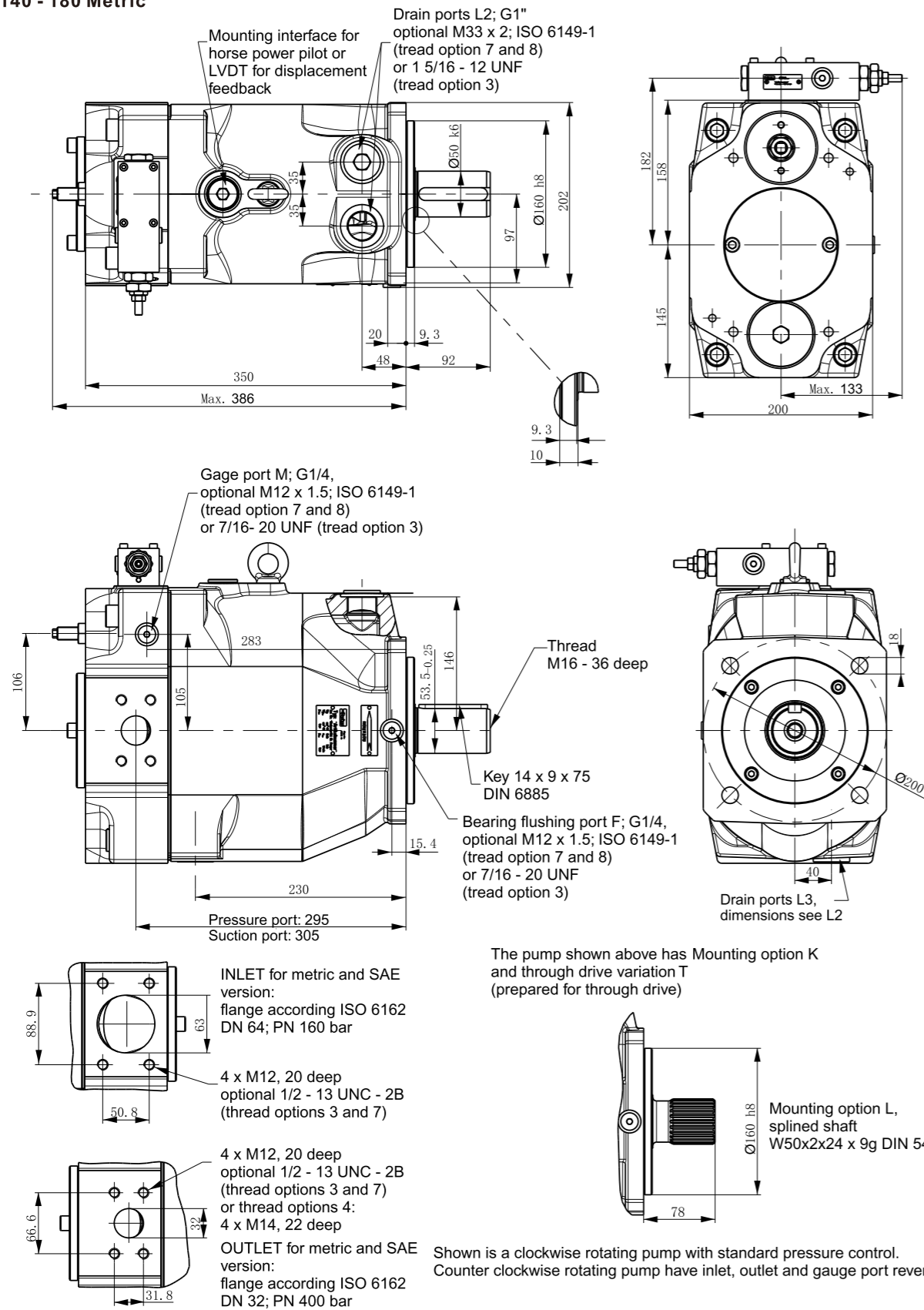

#### PV 140 - 180 SAE Version

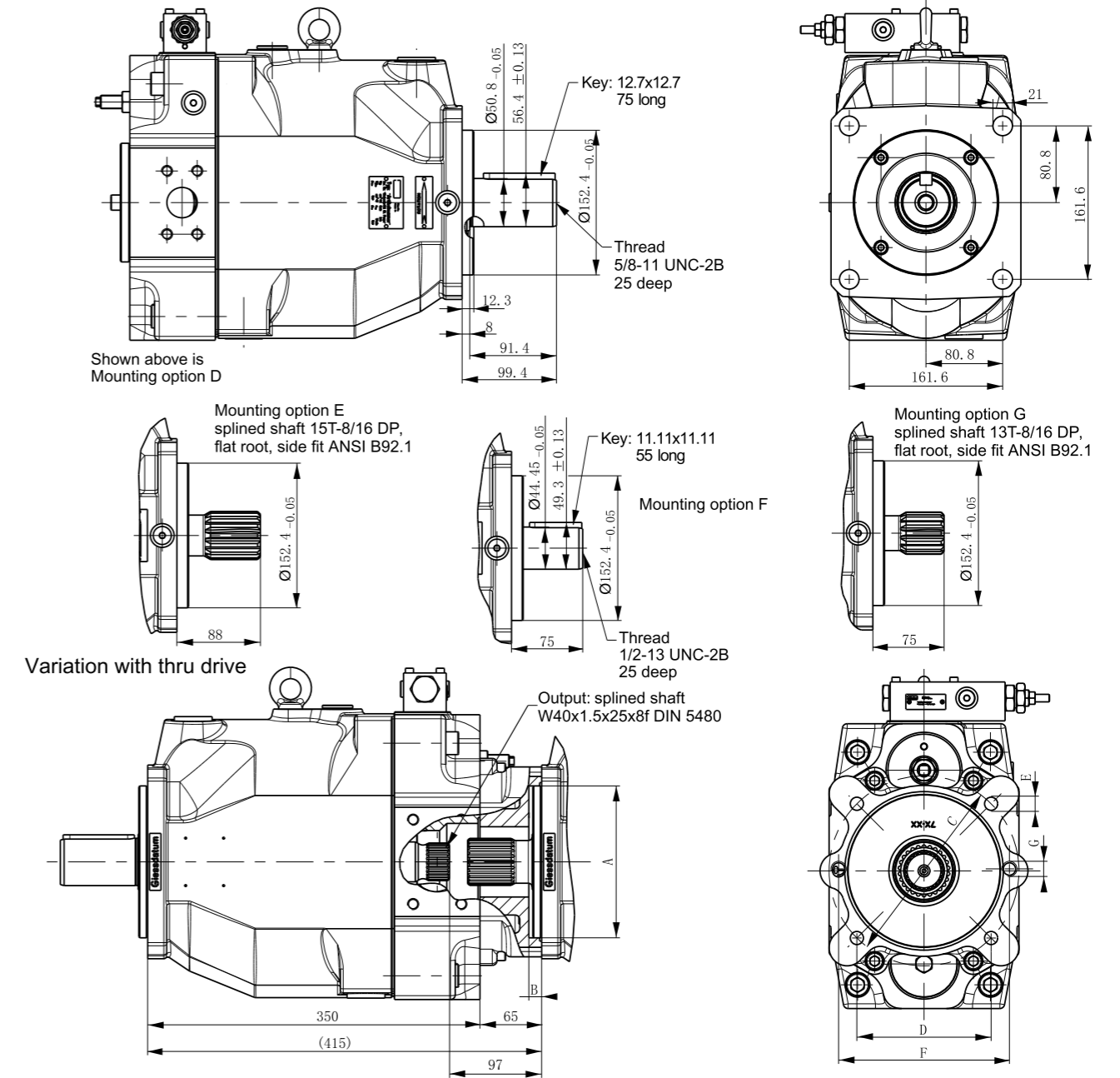

Thru drive adaptors are available with the following dimensions										
Drawing Dimension	A	B	C	D	E		F	G		Remark
					Metr	UNC		Metr	UNC	
Thru drive option										
A	82.55	8	-	-	-	-	106	M10	3/8"-16	SAE A 2-Bolt
B	101.6	11	127	89.8	M12	1/2"-13	146	M12	1/2"-13	SAE B 2/4-Bolt
C	127	13.5	162	114.6	M12	1/2"-13	181	M16	5/8"-11	SAE C 2/4-Bolt
D	152.4	13.5	228.5	161.6	M16	5/8"-11	-	-	-	SAE D 4-Bolt
H	80	8.5	103	72.8	M8	5/16"-18	109	M10	3/8"-16	2/4-Bolt
J	100	10.5	125	88.4	M10	3/8"-16	140	M12	1/2"-13	2/4-Bolt
K	125	10.5	160	113.1	M12	1/2"-13	180	M16	5/8"-11	2/4-Bolt
L	160	13.5	200	141.4	M16	5/8"-11	-	-	-	4-Bolt

#### PV 270 Metric

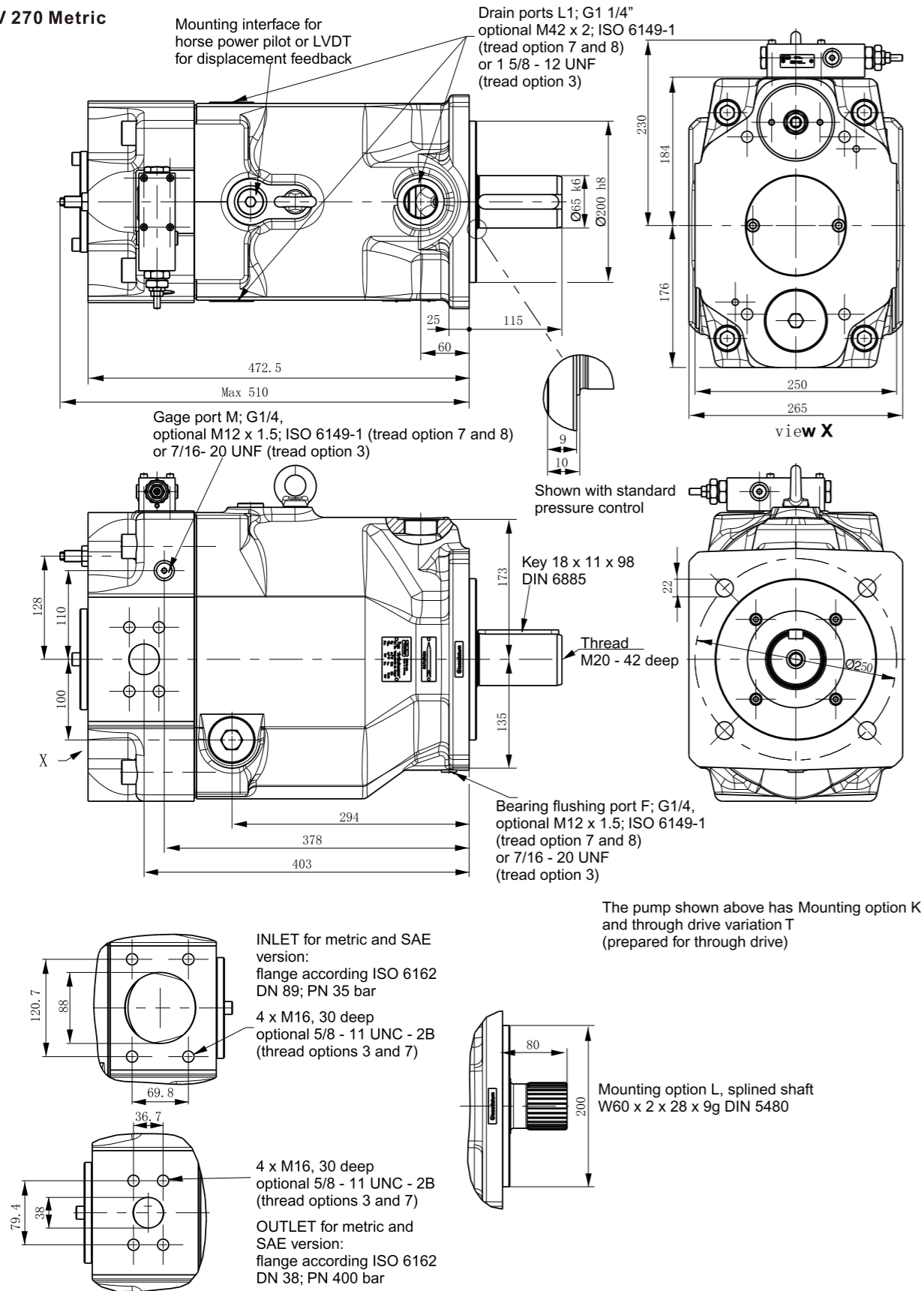

#### PV 270 SAE Version

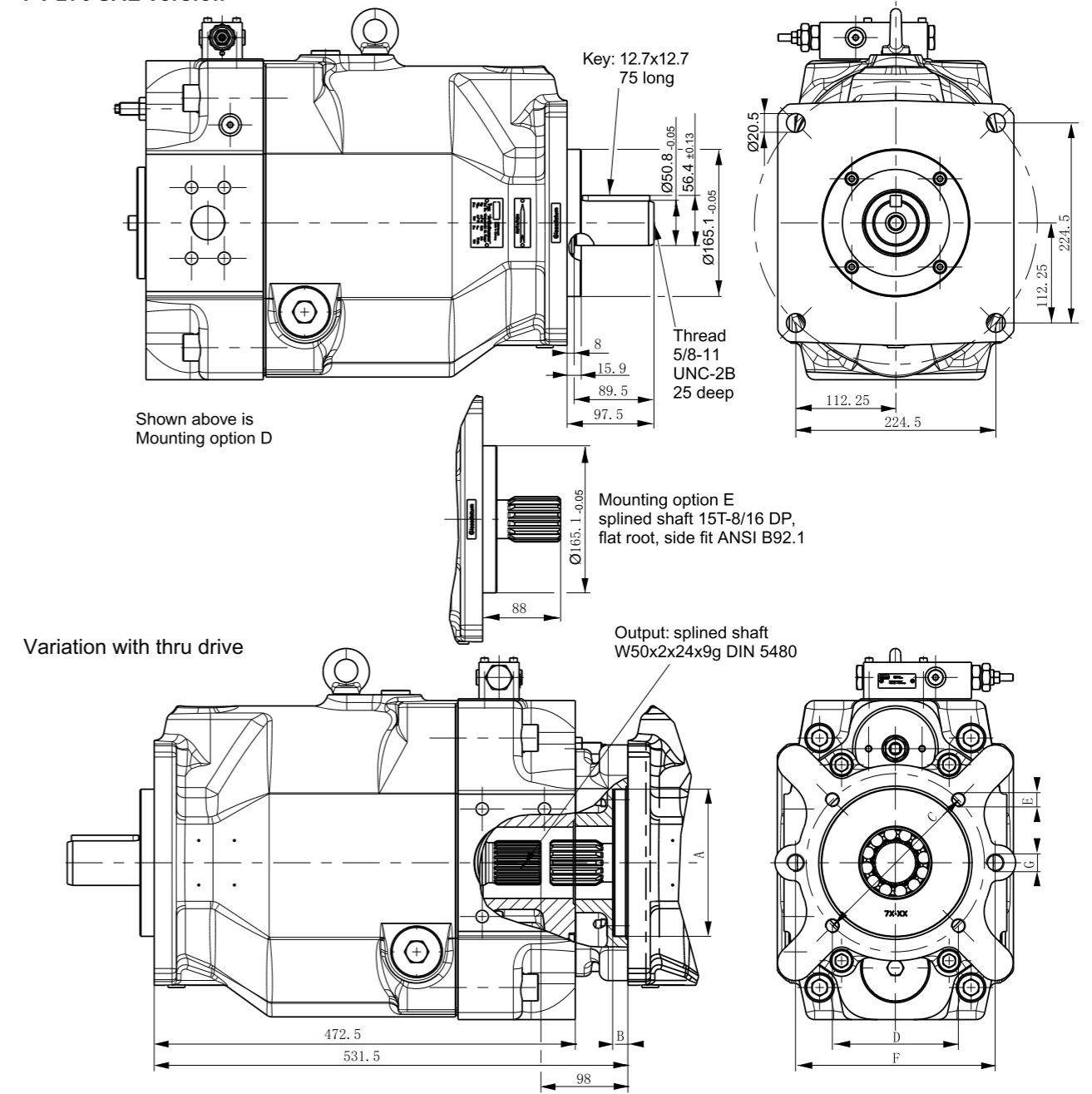

Thru drive adaptors are available with the following dimensions

Drawing Dimension	A	B	C	D	E		F	G		Remark
					Metr	UNC		Metr	UNC	
Thru drive option										
A	82.55	8	-	-	-	-	106	M10	3/8"-16	SAE A 2-Bolt
B	101.6	11	127	89.8	M12	1/2"-13	146	M12	1/2"-13	SAE B 2/4-Bolt
C	127	13.5	162	114.6	M12	1/2"-13	181	M16	5/8"-11	SAE C 2/4-Bolt
D	152.4	13.5	228.5	161.6	M16	5/8"-11	229	M16	5/8"-11	SAE D 2/4-Bolt
E	165.1	17	317.5	224.5	M20	3/4"-10	-	-	-	SAE E 4-Bolt
H	80	8.5	103	72.8	M8	5/16"-18	109	M10	3/8"-16	2/4-Bolt
J	100	10.5	125	88.4	M10	3/8"-16	140	M12	1/2"-13	2/4-Bolt
K	125	10.5	160	113.1	M12	1/2"-13	180	M16	5/8"-11	2/4-Bolt
L	160	13.5	200	141.4	M16	5/8"-11	224	M20	3/4"-10	2/4-Bolt
M	200	13.5	250	176.8	M20	3/4"-10	-	-	-	4-Bolt